

MS-80IR+

MULTISTOMP

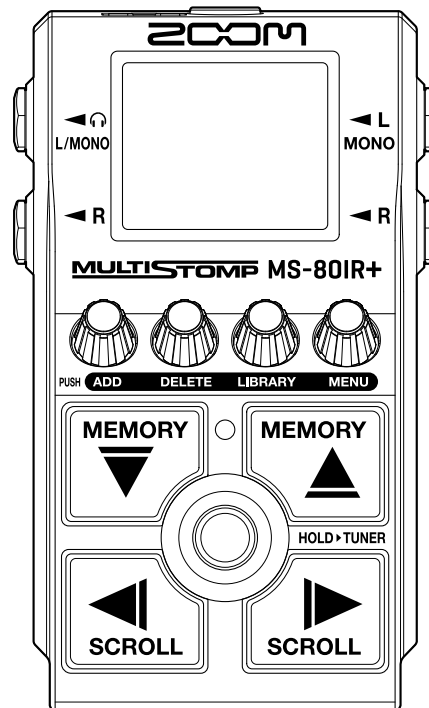

Operation Manual

You must read the Usage and Safety Precautions before use.

©2024 ZOOM CORPORATION

Copying or reprinting this manual in part or in whole without permission is prohibited.

Product names, registered trademarks and company names in this document are the property of their respective companies. All trademarks and registered trademarks in this document are for identification purposes only and are not intended to infringe on the copyrights of their respective owners.

Proper display is not possible on grayscale devices.

Notes about this Operation Manual

You might need this manual in the future. Always keep it in a place where you can access it easily. The contents of this document and the specifications of the product could be changed without notice.

- Microsoft and Windows are trademarks of the Microsoft group of companies.
- iPad, iPadOS, Lightning and Mac are trademarks of Apple Inc.
- App Store is a service mark of Apple Inc.
- IOS is a registered trademark or trademark of Cisco Systems, Inc. and affiliated companies in the USA and other countries, and it is used under license.
- USB Type-C is a trademark of the USB Implementers Forum.
- The illustrations and display screens in this document could differ from the actual product.

Terms used in this manual

Patch memory

Patch memories store effects along with their on/off states and parameter setting values, allowing easy recall. Effects are saved and recalled in units of patch memories. Up to 80 patch memories can be stored and each patch memory can include 1 amp model, 1 studio ambience and 1 other effect.

LIBRARY

Various guitar effects are ready in the LIBRARY. Effects can be selected from the LIBRARY to be added to patch memories.

Category

Effects are grouped by types into categories. The display backlight color changes according to the category.

AUTO SAVE

This function automatically saves changes to patch memory and effect settings.

ECO MODE

This function will automatically turn the power off 10 hours after the last operation.

PRESELECT

This function allows continued use of the current patch memory sound while switching to another patch memory at a distant number.

Contents

Notes about this Operation Manual.....	2
Terms used in this manual.....	3
MS-80IR+ overview.....	6
Signal flow.....	6
Patch memory structure.....	7
Functions of parts.....	8
Top.....	8
Back.....	9
Overview of operation screens.....	10
Home Screen.....	10
LIBRARY Screen.....	11
MENU Screen.....	12
Making connections.....	15
Turning the power on/off.....	16
Turning the power on.....	16
Turning the power off.....	18
Adjusting the overall output level.....	19
Adjusting effects.....	20
Turning effects on/off.....	20
Switching effects.....	22
Adjusting effect parameters.....	23
Adding effects.....	25
Deleting effects.....	27
Changing the order of effects.....	29
Tapping to change the tempo.....	31
Changing the tempo.....	33
Changing the R channel signal output position.....	35
Switching patch memories.....	37
Using the PRESELECT function.....	38
Turning the PRESELECT function on/off.....	38
Selecting patch memories when PRESELECT is on.....	40
Managing patch memories.....	41
Changing patch memory names.....	41
Copying and saving patch memories.....	43
Erasing patch memories.....	45
Creating patch memories.....	47
Restoring patch memories to original settings.....	49
Using the tuner.....	51
Activating the tuner.....	51
Changing tuner settings.....	52

Using impulse responses (IR).....	56
Loading impulse response (IR) data.....	56
Using impulse responses (IR).....	56
Using audio interface functions.....	58
Installing drivers.....	58
Connecting to computers, smartphones and tablets.....	59
Adjusting the volume of USB audio sent to the computer.....	60
Adjusting the monitoring balance for USB audio.....	61
Operating the MS-80IR+ from an iPhone/iPad.....	62
Making unit settings.....	64
Setting the AUTO SAVE function.....	64
Setting the sound used on the LIBRARY Screen.....	65
Setting the type of batteries used.....	66
Adjusting the backlight brightness.....	67
Adjusting the display contrast.....	68
Setting the ECO MODE.....	69
Setting the channel used to receive USB MIDI.....	70
Managing the firmware.....	71
Checking the firmware version.....	71
Updating the firmware.....	71
Restoring factory default settings.....	72
Checking the latest MS-80IR+ information.....	73
Appendix.....	74
Troubleshooting.....	74
Specifications.....	75
MIDI implementation chart.....	77

MS-80IR+ overview

Signal flow

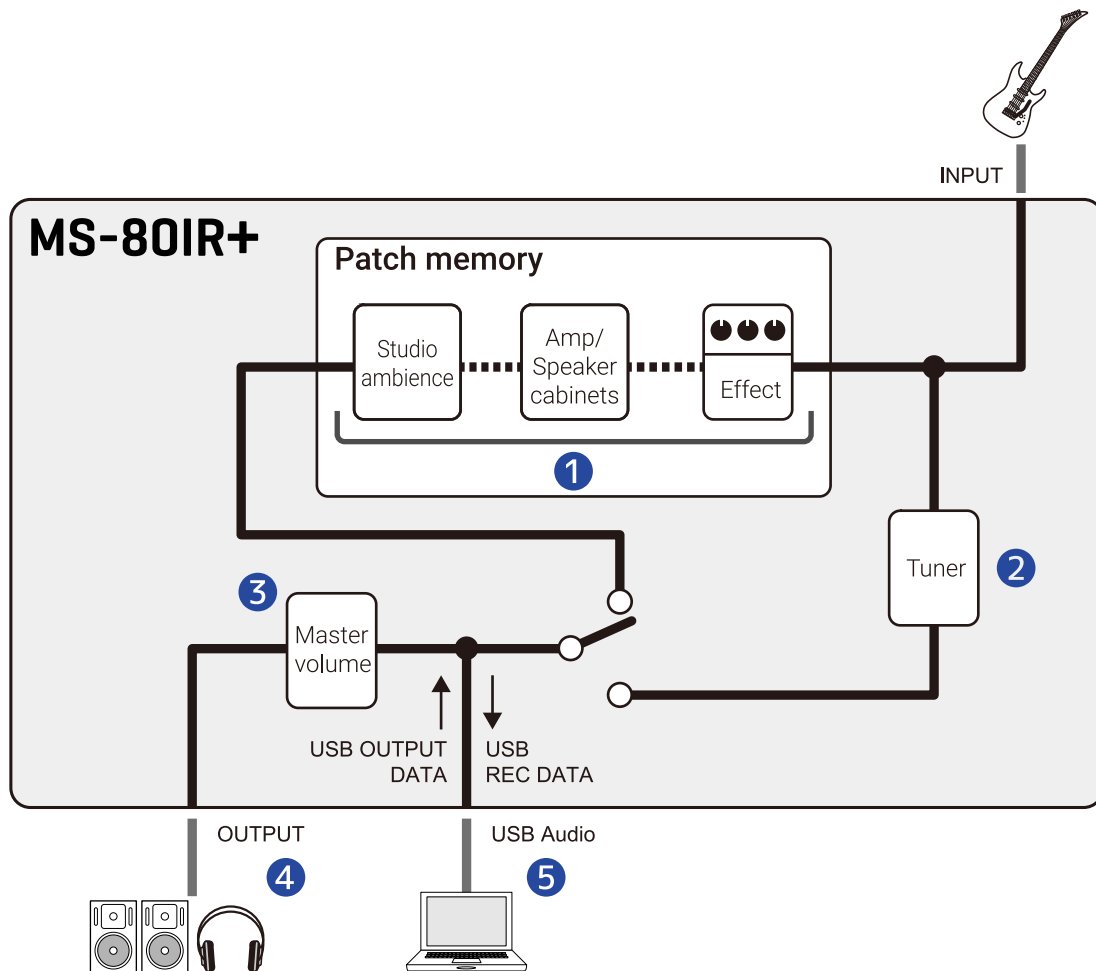

- 1 Patch memory**
The input guitar sound passes through effects in order. (→ [Adjusting effect parameters](#))
- 2 Tuner**
Use this to tune the connected guitar. (→ [Using the tuner](#))
- 3 Master volume**
This adjusts the overall volume. This setting is retained even when the patch memory is changed. (→ [Adjusting the overall output level](#))
- 4 OUTPUT**
Connect powered monitors or headphones here.
- 5 USB audio**
Audio data can be exchanged with a computer or smartphone using the audio interface function. (→ [Using audio interface functions](#))

Patch memory structure

Patch memories

These store the effects used, their order, on/off states and parameter settings. Effects are saved and recalled in units of patch memories. Up to 80 of these can be stored.

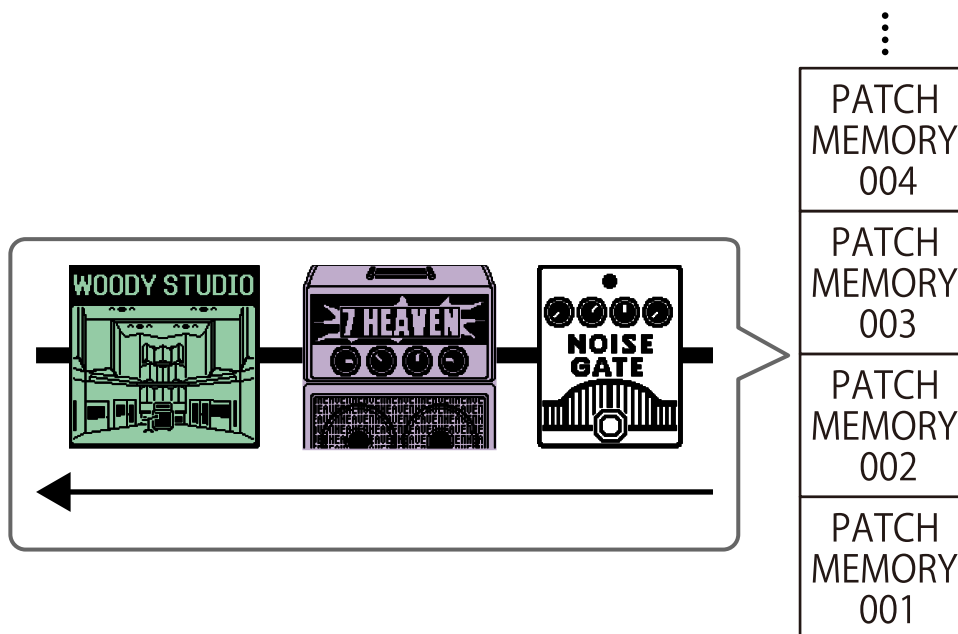

Functions of parts

Top

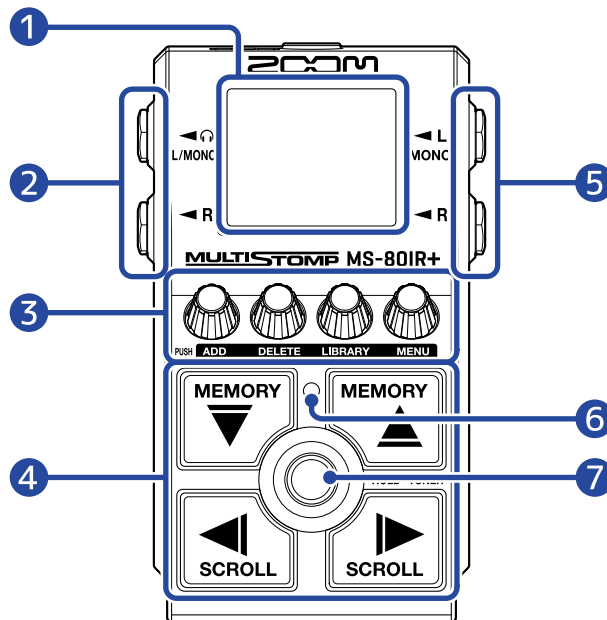

- 1 Display**
This shows information, including the name of the selected effect along with its parameter values.
- 2 Output jacks**
Connect these to powered monitors or headphones.
Use MONO for mono connections.
- 3 Parameter knobs**
Use these to adjust effect parameters and make various settings.
- 4 Direction switches**
Use these to select patch memories and effects, for example.
They can be operated by foot.
- 5 Input jacks**
Connect a guitar or another effect here.
- 6 On/Off indicator**
Use this to check if an effect is on or off.
- 7 Footswitch**
Use this to turn effects on and off.

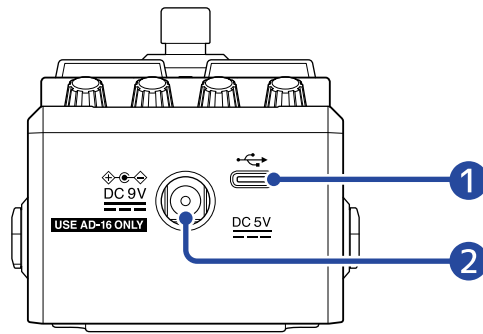

1 USB (Type-C) port

Connected to a computer, smartphone or tablet, this can be used as an audio interface. By using Handy Guitar Lab, you can also manage patch memories and edit and add effects, for example, from a smartphone or tablet.

This supports operation on USB bus power.

2 DC 9V AC adapter connector

Connect a dedicated AC adapter (ZOOM AD-16) here.

Overview of operation screens





The MS-80IR+ is operated by using its buttons and knobs while looking at screens on the display. This section explains those screens.

Home Screen

This appears when the power is turned on.



Effects in the selected patch memory are shown. The patch memory can be edited and its effects turned on and off.



- Use  and  to select patch memories.
- Use  and  to select the effects in the patch memory.
The backlight color changes according to the category of the selected effect.



Opening the Home Screen

- If the [MENU Screen](#) is open, press  .
- If the [LIBRARY Screen](#) is open, press  to confirm the selected effect.

LIBRARY Screen

Effects in patch memories can be changed.

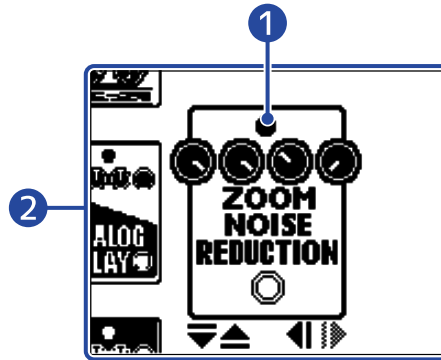





1 Selected effect

The selected effect is shown larger in the middle.



The backlight color changes according to the category of the selected effect.

2 Effect list

Effects in the same category are ordered vertically. Use  and  to select effects in the same category.

Use  and  to select effects in different categories.

Opening the LIBRARY Screen

On the [Home Screen](#), use  and  to select an effect to replace, and press .

Closing the LIBRARY Screen

Press  to confirm the selected effect and reopen the [Home Screen](#).

MENU Screen

Various MS-80IR+ settings can be made.

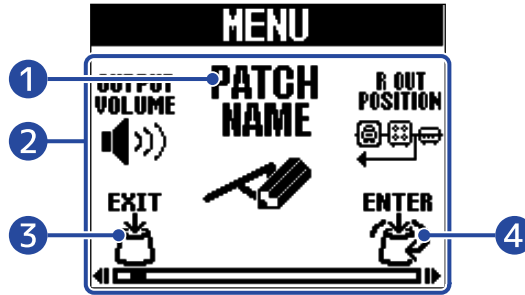

1 Selected setting item

The selected setting item is shown larger in the middle.

2 Setting items

Setting items are shown with icons. Turn  to select them.

3 EXIT

This reopens the [Home Screen](#).

4 ENTER

This shows the selected setting item.

Using the MENU Screen

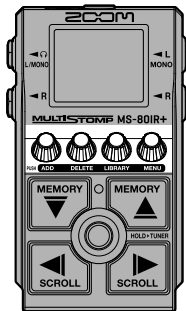



















1. Press  to open the MENU Screen.

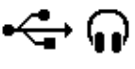
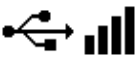

2. Turn  to show the icon for the desired setting item.

Please see the linked reference sections for details about each setting.

<p>OUTPUT VOLUME</p> 	<p>Adjust the overall output level. (→ Adjusting the overall output level)</p>	<p>PATCH NAME</p> 	<p>Change the patch memory name. (→ Changing patch memory names)</p>
<p>R OUT POSITION</p> 	<p>Change the position in the patch memory from which the R channel signal is output. (→ Changing the R channel signal output position)</p>	<p>MOVE EFFECT</p> 	<p>Change the effect order. (→ Changing the order of effects)</p>
<p>BPM</p> 	<p>Change the tempo. (→ Changing the tempo)</p>	<p>REVERT PATCH</p> 	<p>Restore the patch memory to its original settings. (→ Restoring patch memories to original settings)</p>
<p>COPY PATCH</p> 	<p>Copy and save patch memories. (→ Copying and saving patch memories)</p>	<p>NEW PATCH</p> 	<p>Create a new patch memory. (→ Creating patch memories)</p>
<p>ERASE PATCH</p> 	<p>Erase a patch memory. (→ Erasing patch memories)</p>	<p>AUTO SAVE</p> 	<p>Turn the AUTO SAVE function on/off. (→ Setting the AUTO SAVE function)</p>
<p>PRE-SELECT</p> 	<p>Turn the PRESELECT function on/off. (→ Using the PRESELECT function)</p>	<p>LIBRARY SOUND</p> 	<p>Set the sound used on the LIBRARY Screen. (→ Setting the sound used on the LIBRARY Screen)</p>
<p>BATTERY TYPE</p> 	<p>Set the type of batteries used. (→ Setting the type of batteries used)</p>	<p>BACKLIGHT</p> 	<p>Adjust the backlight brightness. (→ Adjusting the backlight brightness)</p>
<p>CONTRAST</p> 	<p>Adjust the display contrast. (→ Adjusting the display contrast)</p>	<p>ECO MODE</p> 	<p>Turn ECO MODE on/off. (→ Setting the ECO MODE)</p>
<p>USB MONITOR</p> 	<p>Adjust the monitoring balance for USB audio. (→ Adjusting the monitoring balance for USB audio)</p>	<p>USB REC GAIN</p> 	<p>Adjust the volume (recording level) sent to the computer or other device using USB audio. (→ Adjusting the volume of USB audio sent to the computer)</p>
<p>USB MIDI CH</p> 	<p>Set the channel used to receive USB MIDI. (→ Setting the channel used to receive USB MIDI)</p>	<p>FACTORY RESET</p> 	<p>Restore settings to their factory defaults. (→ Restoring factory default settings)</p>

VERSION

Check the firmware version.
 (→ [Checking the firmware version](#))

HELP

Show a 2D code for checking MS-80IR+ operation procedures.
 (→ [Checking the latest MS-80IR+ information](#))

3. Press .

This opens the selected setting screen.
 (This example is when "AUTO SAVE" is selected.)

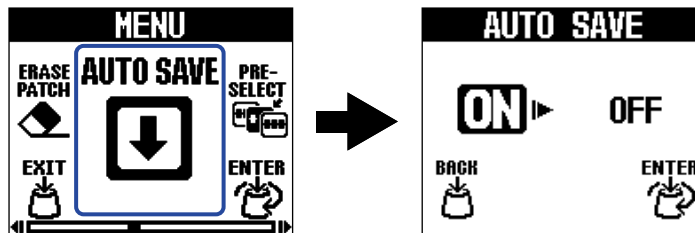

4. Turn to select a setting.

The selected item is highlighted.



5. Press .

This confirms the setting.

HINT

When a setting screen is open, press to return to the [Home Screen](#) or [MENU Screen](#).

- When appears at the bottom left of the screen, this opens the [Home Screen](#).
- When appears at the bottom left of the screen, this opens the [MENU Screen](#).

Making connections

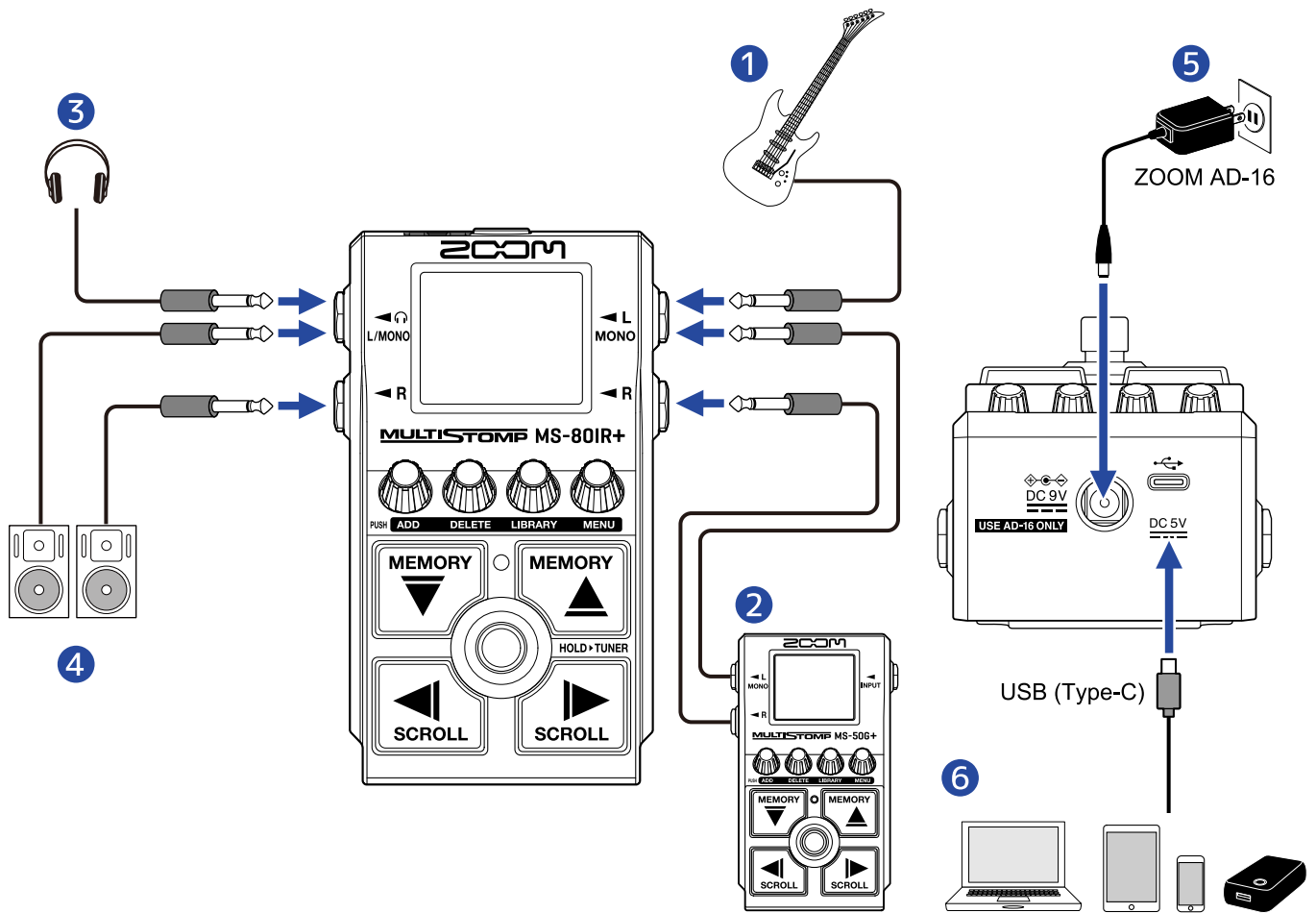

- 1 Guitar
- 2 Effect
- 3 Headphones
- 4 Powered monitors
- 5 AC adapter (ZOOM AD-16)
- 6 Computer (Mac/Windows), iPhone/iPad or portable battery

Connect with a USB cable (Type-C).

Connect to this port to use the MS-80IR+ as an audio interface, use Handy Guitar Lab for MS-80IR+ or provide power with a portable battery.

The Handy Guitar Lab for MS-80IR+ iOS/iPadOS app can be used to manage patch memories and to edit and add effects. Handy Guitar Lab for MS-80IR+ can be downloaded from the App Store.

Turning the power on/off

Turning the power on

1. Minimize the volume of powered monitors.

NOTE

To prevent noise and malfunction, connect powered monitors before turning the power on.

2. Supplying power

■ Using batteries

Open the cover on the bottom and install batteries into the battery compartment.

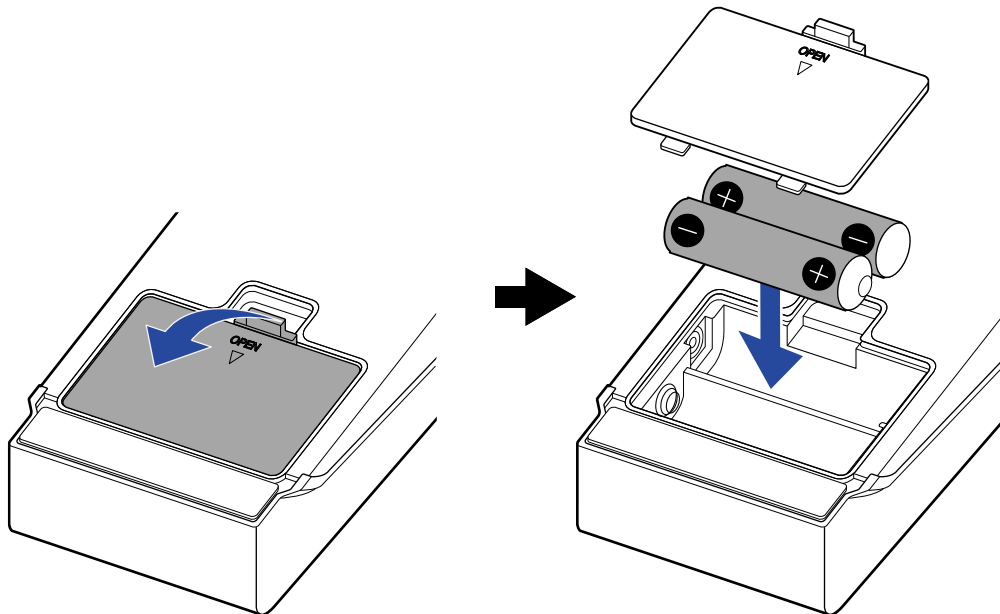

NOTE

- Use only one type of battery (alkaline, NiMH or lithium) at a time.
- Set the type of battery used correctly so that the amount of remaining battery charge can be shown accurately. (→ [Setting the type of batteries used](#))

■ Using an AC adapter

Use a ZOOM AD-16 AC adapter, which is specified for this unit.

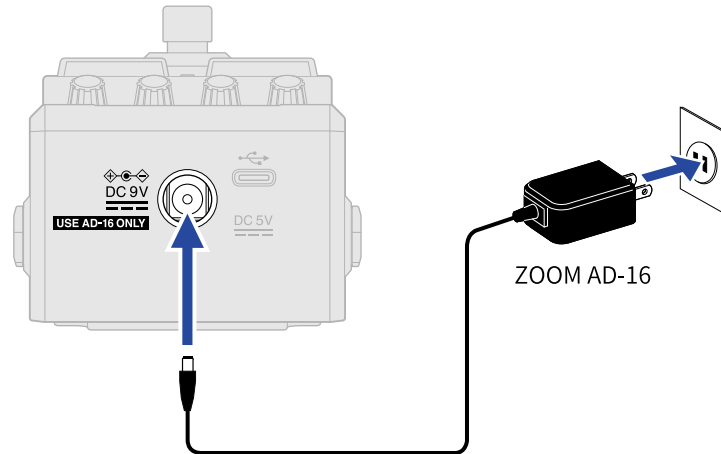

When an AC adapter is connected, the MS-80IR+ will power on.

3. Connect a cable to the input jack.

When using batteries for power, connecting a cable to the L/MONO input jack will turn on the power. This turns on the MS-80IR+ power and opens the [Home Screen](#).



NOTE

The power will not turn on if only the R input jack has a cable connected to it. Confirm that a cable is connected to the L/MONO jack.

4. Raise the volume of powered monitors.

ECO MODE overview

- By default, ECO MODE is set to ON, so the power will automatically turn off if no use occurs for 10 hours.
- ECO MODE can also be turned OFF. (→ [Setting the ECO MODE](#))

Turning the power off

1. Minimize the volume of powered monitors.

2. Disconnect the cable from the input jack.

■ **If using batteries**

Disconnect the cable from the L/MONO input jack to turn off the display and the power.

■ **If using an AC adapter**

Disconnect the AC adapter to turn off the display and the power.

Adjusting the overall output level

The volume of the MS-80IR+ output sound can be adjusted.

1. Select "OUTPUT VOLUME" on the [MENU Screen](#).

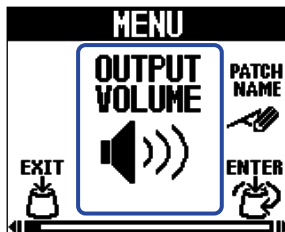

2. Turn  to adjust the volume.

The setting value is shown on the display.

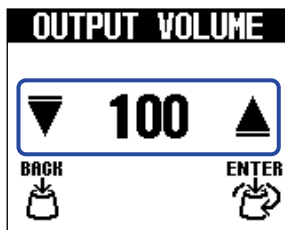

3. Press .

This confirms the setting.

4. Press .

This reopens the [Home Screen](#).

Adjusting effects

Patch memories can be edited, including replacing effects and adjusting parameters.

Saving changes



- When the AUTO SAVE function is ON, changes to patch memories will be saved automatically. (The default setting is ON.) (→ [Setting the AUTO SAVE function](#))
- If the AUTO SAVE function is OFF, patch memories will not be saved automatically. When the content of a patch memory has been changed, **EDITED** will appear at the top right of the display, showing that it is different from the saved settings. Save them as necessary. (→ [Copying and saving patch memories](#))



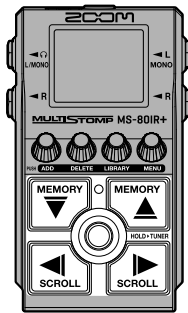

Turning effects on/off

On the [Home Screen](#), the effects used in the patch memory are shown and can be turned on and off using the footswitch.



1. Use  and  on the [Home Screen](#) to select a patch memory with an effect you want to turn on/off. (→ [Switching patch memories](#))

2. Use  and  to select the effect you want to turn on/off.

One effect in the patch memory is shown on the display.

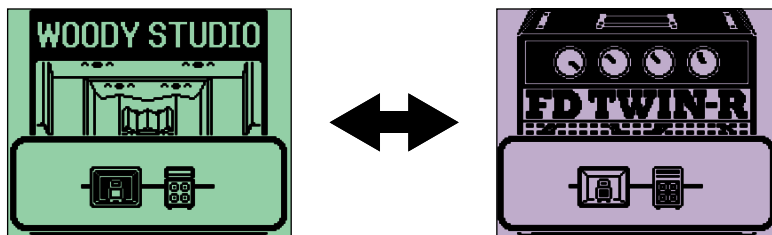

3. Press  to turn the effect on/off.

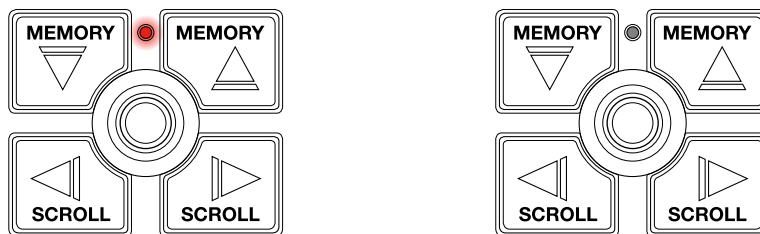
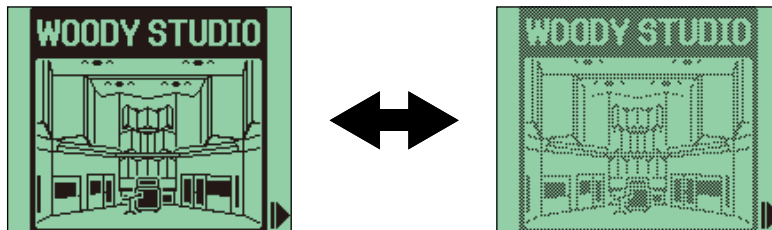



The On/Off indicator lights when the effect is on.

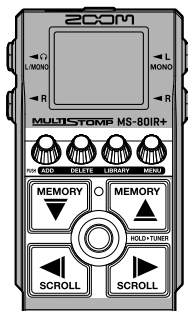

When the effect is off, the On/Off indicator is unlit and the effect icon appears faded on the display.

Switching effects

Effects in a patch memory can be replaced with other effects as desired.



1. Use  and  on the [Home Screen](#) to select the patch memory with an effect that you want to replace. (→ [Switching patch memories](#))

2. Use  and  to select the patch you want to replace.

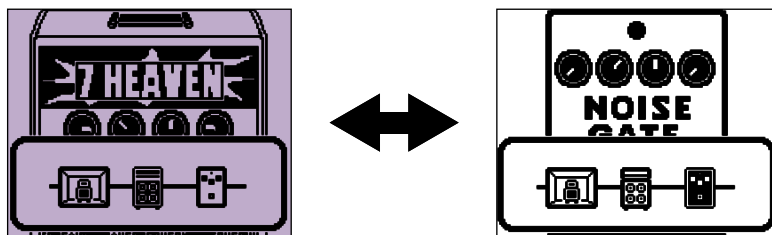

3. Press .

This opens the [LIBRARY Screen](#) that shows all the effects.

When the LIBRARY Screen is open, you can preview the sound of only the selected effect or the entire patch memory. (→ [Setting the sound used on the LIBRARY Screen](#))

4. Use , ,  and  to select effects.

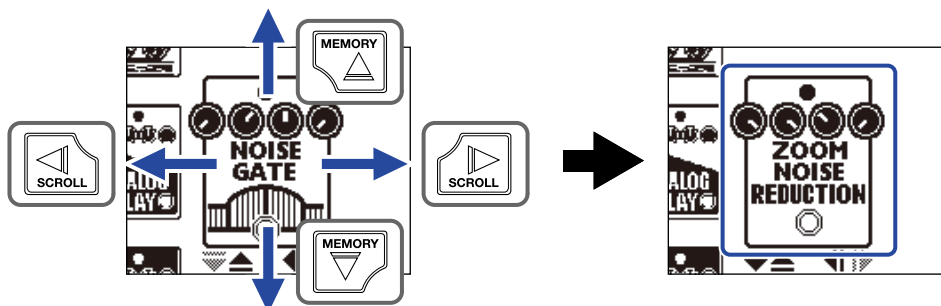

HINT

Turn  to show the Effect Adjustment Screen where the parameters of the selected effect can be adjusted. (→ [Adjusting effect parameters](#))

5. Press .

This replaces the selected effect and reopens the [Home Screen](#).

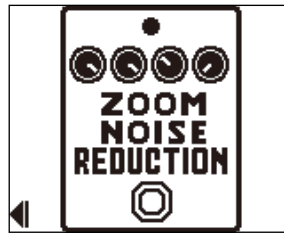



NOTE

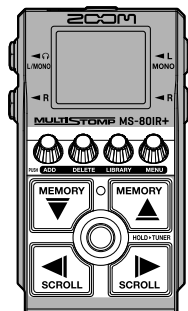

- If an effect has been deleted using the Handy Guitar Lab for MS-80IR+ app,  will appear and it will be disabled.
- One effect in the amp category, one effect in the studio category and one other effect can each be selected in a patch memory.

Adjusting effect parameters

The individual effects used in patch memories can be adjusted.



1. Use  and  on the [Home Screen](#) to select the patch memory with an effect that you want to replace. (→ [Switching patch memories](#))

2. Use  and  to select the effect with parameters that you want to adjust.

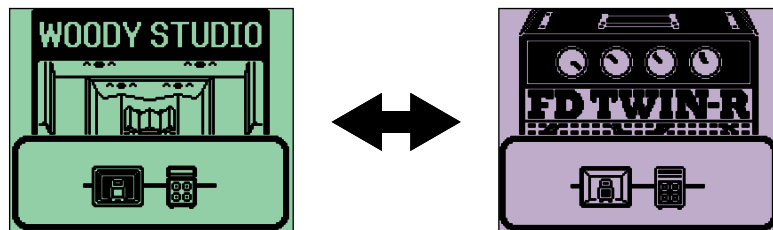

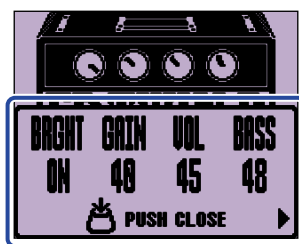

3. Turn .

This opens the Parameter Adjustment Screen of the selected effect.



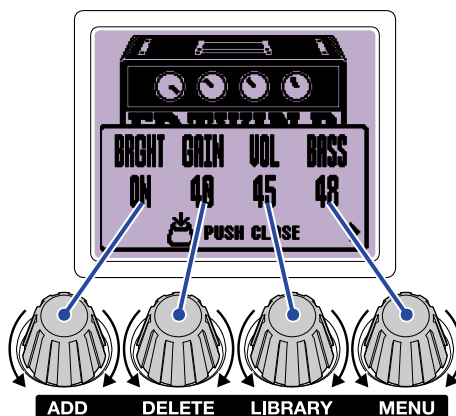

4. Turn  to adjust an effect parameter.



Press  to return to the original screen.

When parameters are on multiple pages, ◀ and ▶ will appear at the bottom of the screen.

Use  and  to show the parameters to be adjusted.

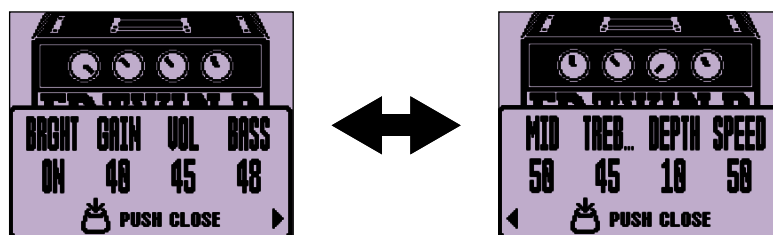

HINT

Set TIME, SPEED and other effect parameters to musical notes to synchronize them to the tempo.





(→[Tapping to change the tempo](#))

Adding effects

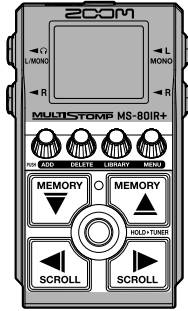
Effects can be added to patch memories.

One amp model, one studio ambience and one other effect can be combined freely on the MS-80IR+.



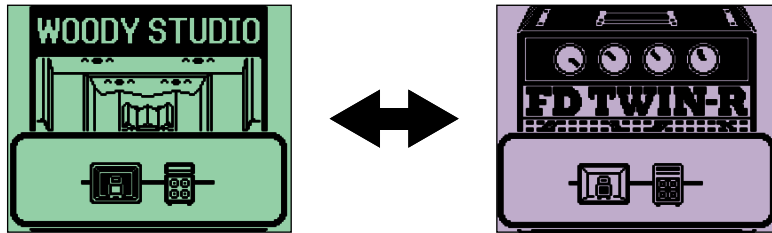

1. Use  and  on the [Home Screen](#) to select the patch memory to which you want to add an effect. (→ [Switching patch memories](#))
2. Use  and  to select the position where you want to add an effect.
The effect can be added to the left of (after) or the right of (before) the shown effect.

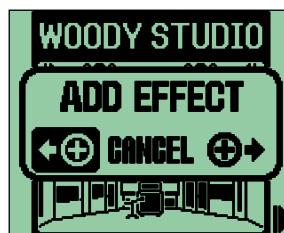

3. Press .

This opens the ADD EFFECT Screen.



4. Turn  to select whether to add it to the left or the right, and press .

This opens the [LIBRARY Screen](#) that shows all the effects. Select the effect to add. (→ [Switching effects](#))

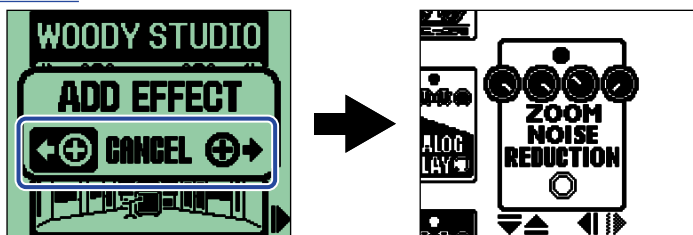

To cancel adding an effect, turn  on the ADD EFFECT Screen and select "CANCEL". Then, press



NOTE

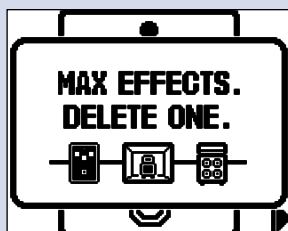

- If  is pressed when 3 effects have already been added to the patch memory, the following message will appear and adding the effect will fail. In this case, delete an effect from the patch memory first. (→ [Deleting effects](#))



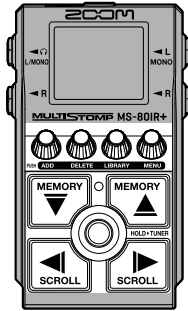

Deleting effects

Effects in patch memories can be deleted.



1. Use  and  on the [Home Screen](#) to select the patch memory with the effect that you want to delete. (→ [Switching patch memories](#))

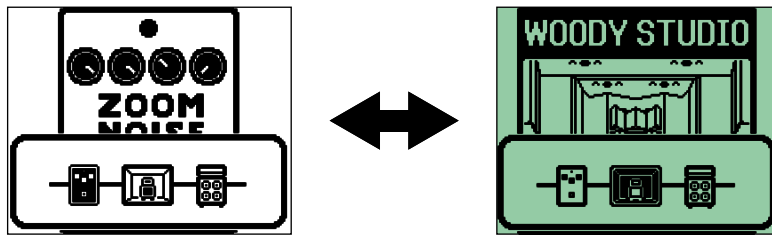

2. Use  and  to select the effect to delete.

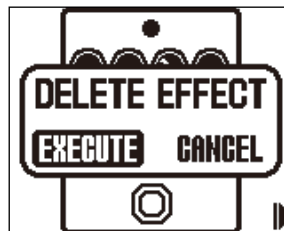

3. Press .

This opens the DELETE EFFECT Screen.



4. Turn  to select "EXECUTE" and press .

This will delete the selected effect from the patch memory. The effect that was to the left of that effect will be shown.

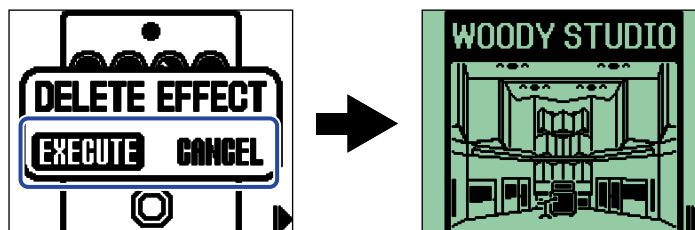

To cancel effect deletion, turn  to select "CANCEL" and press .

HINT

If the amp category effect is deleted, the SELECT AMP Screen will open. Press  and select an effect.

(→ [Switching effects](#))

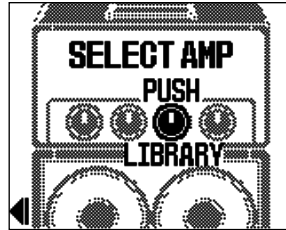



NOTE

Studio category effects cannot be deleted.

Changing the order of effects

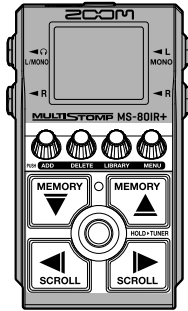
Effects in a patch memory can be reordered as desired.



1. Use  and  on the [Home Screen](#) to select a patch memory with effects that you want to reorder. (→ [Switching patch memories](#))

2. Press  and  to select an effect to reorder.

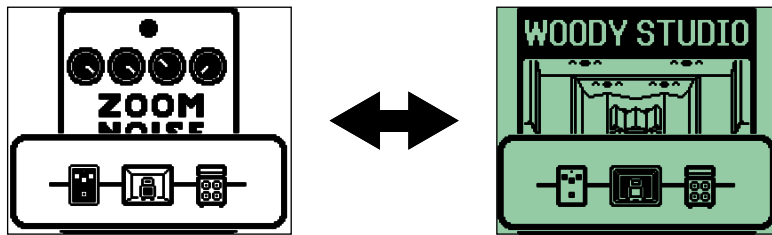

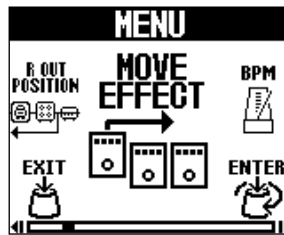

3. Press  to open the [MENU Screen](#).



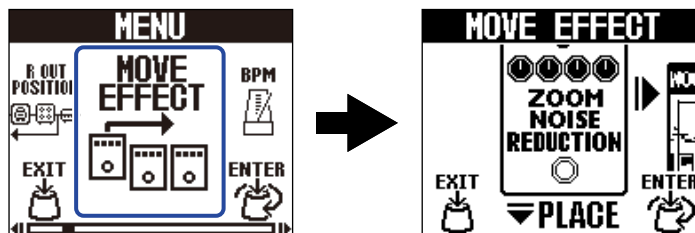

4. Turn  to select "MOVE EFFECT" and press .

This opens the MOVE EFFECT Screen.

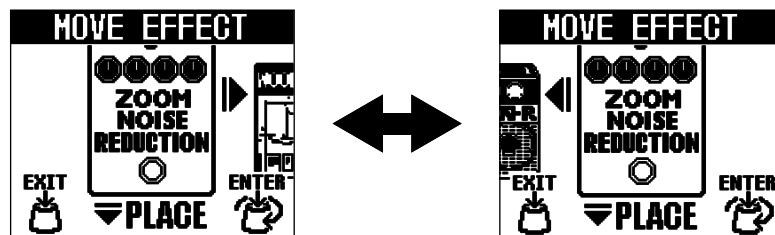

5. Turn  to move the effect to the desired position.





6. Press .





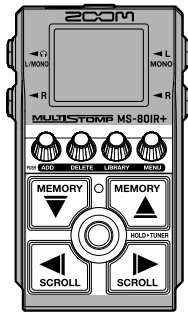

This confirms reordering and reopens the [Home Screen](#).

Tapping to change the tempo

The BPM, which is used to synchronize the tempo of the tremolo in amp models, for example, can be set separately for each patch memory.



1. Use  and  on the [Home Screen](#) to select the patch memory with the tempo that you want to adjust. (→ [Switching patch memories](#))

2. Press  to open the [LIBRARY Screen](#). Then, use , ,  and  to select the BPM module, and press . (→ [Adding effects](#))

The BPM module is in the tool category (white) of the [LIBRARY Screen](#).

This adds the BPM module to the patch memory.

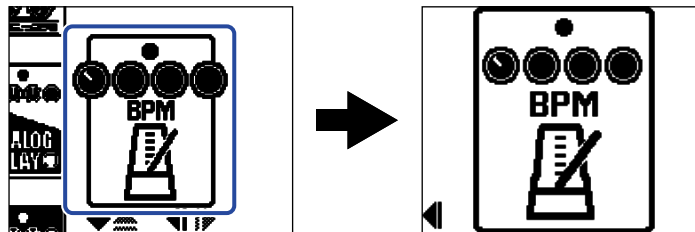

NOTE

The BPM module cannot be added if the patch memory already has 3 effects. In this case, delete an effect from the patch memory first. (→ [Deleting effects](#))

3. Press .

The tempo can be set by tapping  repeatedly (tap tempo).

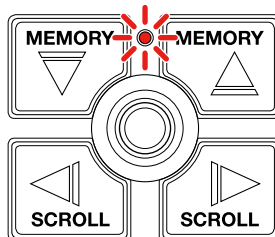



The indicator blinks at the set tempo interval.

If a BPM module is added to a patch memory, that module can then be used to change the tempo of the patch memory.

HINT

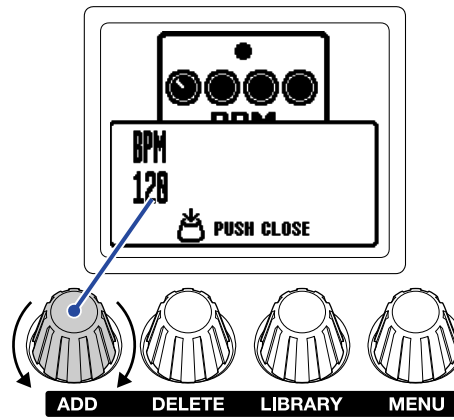
- The tempo setting range is 40–250 ♩ (bpm).
- Turn  to show the Tempo Adjustment Screen where the tempo can be set numerically.





Press  to return to the original screen.

Changing the tempo

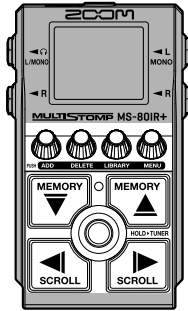

The tempo can also be changed from the MENU.

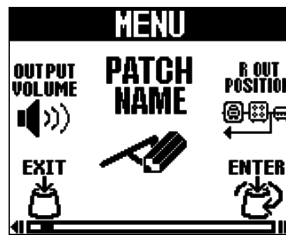

1. Use  and  on the [Home Screen](#) to select the patch memory with the tempo that you want to adjust. (→ [Switching patch memories](#))

2. Press  to open the [MENU Screen](#).



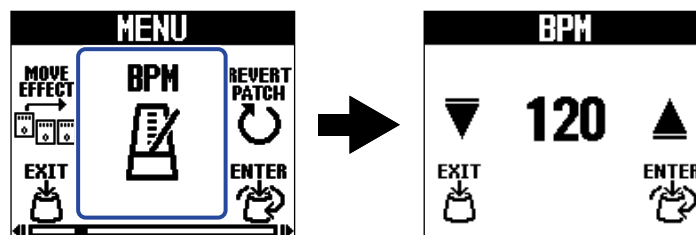

3. Turn  to select "BPM", and press .

This opens the BPM Screen.

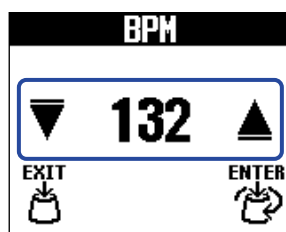

4. Turn  to set the tempo.



5. Press  .

This reopens the [Home Screen](#).



HINT

The tempo adjusted here is linked to the tempo adjusted in the BPM module of the patch memory and will be used by all its effects.

Changing the R channel signal output position

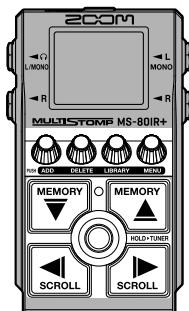
The output position of the R channel signal can be set separately for each patch memory.



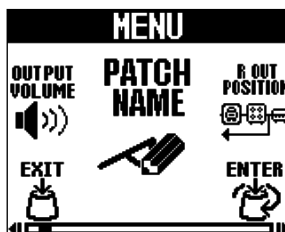

1. Use  and  on the [Home Screen](#) to select a patch memory for which you want to change the output position of the R channel signal. (→ [Switching patch memories](#))

2. Press  to open the [MENU Screen](#).

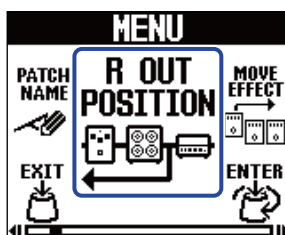

3. Select "R OUT POSITION" on the [MENU Screen](#) and press .



4. Turn  to switch the setting.

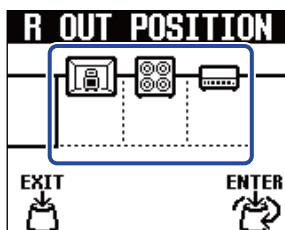

5. Press .

This confirms the setting and reopens the [Home Screen](#).

HINT

- If anywhere other than the end is selected, the signal output position is shown when effects are selected, for example.



- Between the amp head and cabinet can also be selected.

Effective use of the R OUT POSITION

When using the MS-80IR+ on stage performing live, for example, suitable sounds can be output separately for a PA system and for a guitar amp.

For the PA system, sound processed by a cabinet simulation and another effect can be output from the L output jack. For the guitar amp, sound processed only by an amp head model can be output from the R output jack.

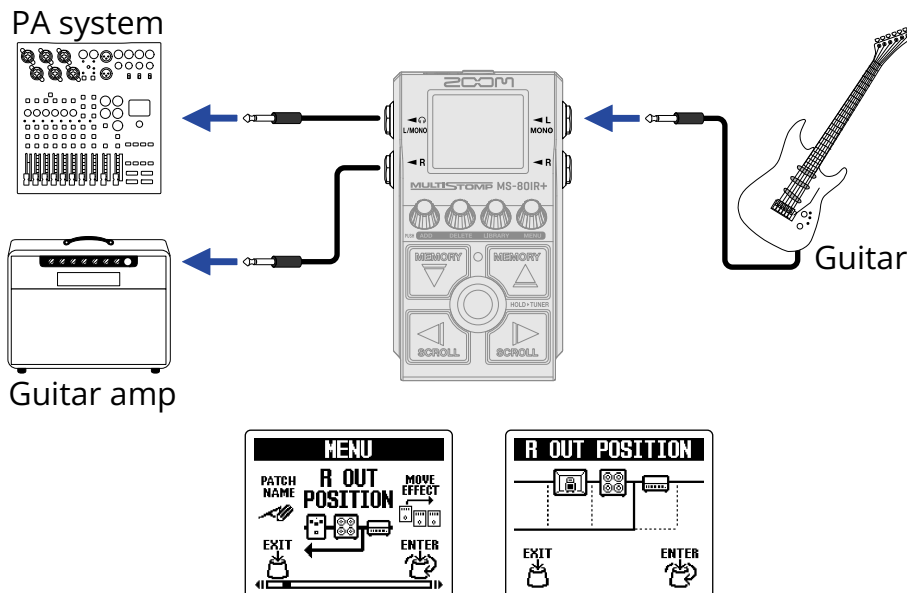

Switching patch memories

The MS-80IR+ manages effects in patch memories. A patch memory can save effect on/off states and parameter settings for up to one amp model, one studio ambience and one other effect.

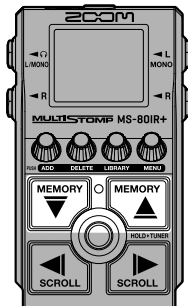

1. Use  and  on the [Home Screen](#) to select a patch memory.

When a patch memory is selected, information about it will be shown briefly.

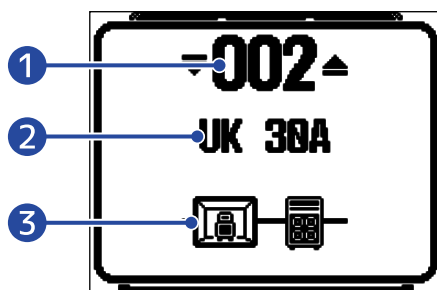

- 1 Patch memory number

This shows the number of the selected patch memory.

- 2 Patch memory name

This shows the name of the selected patch memory.

- 3 Number of effects in the patch memory



This shows the number of effects in the selected patch memory.

HINT

- Up to 80 patch memories can be created.
 - The MS-80IR+ has a PRESELECT function. This allows the next patch memory to be selected in advance and then switched to with one press. This is useful when you want to switch to a patch memory that is not near the current one when performing live, for example. (→ [Using the PRESELECT function](#))
-

Using the PRESELECT function

The MS-80IR+ has a PRESELECT function.

If PRESELECT is ON, the change will not occur immediately when  and  are used to switch patch memories. Pressing  afterward will finalize the patch memory change.

This makes it possible to switch directly to a patch memory that is not near the current one during live performance.

Turning the PRESELECT function on/off

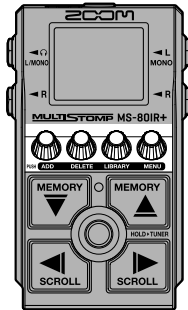



1. Press  to open the MENU Screen.

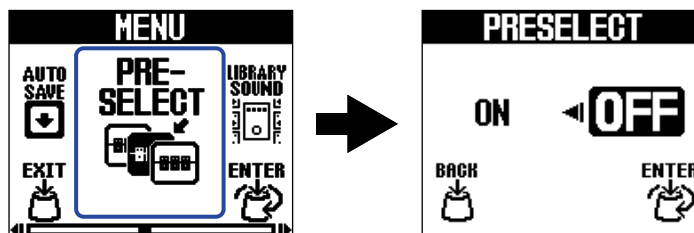

2. Turn  to select "PRESELECT" and press .

This opens the PRESELECT Screen.



3. Turn  to switch it ON/OFF.

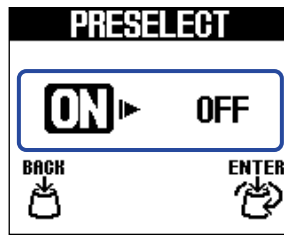

Setting	Explanation
ON	This turns on the PRESELECT function.
OFF	This turns off the PRESELECT function.

4. Press .

This confirms the setting.

5. Press .

This reopens the [Home Screen](#).

Selecting patch memories when PRESELECT is on

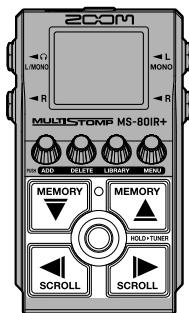

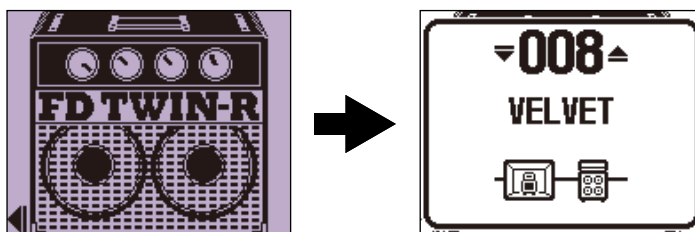

1. Use  and  on the [Home Screen](#) to show the next patch memory to select.

Example: Selecting patch memory 008 while performing with 001

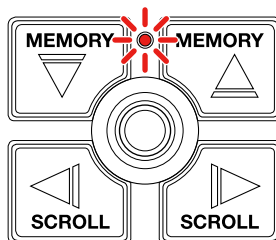

The On/Off indicator will blink.



2. Press  to confirm the selection.



An effect in the selected patch memory will be shown.

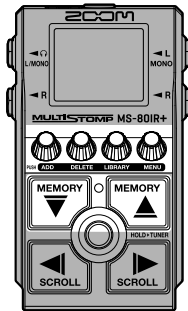

Managing patch memories

Changing patch memory names



1. Use  and  on the [Home Screen](#) to select the patch memory with the name that you want to change. (→ [Switching patch memories](#))

2. Press  to open the [MENU Screen](#).

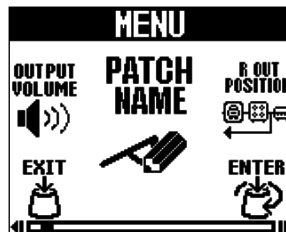

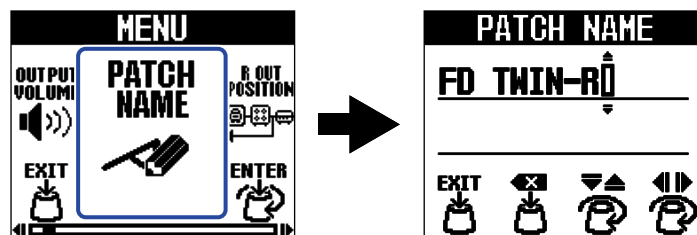

3. Turn  to select "PATCH NAME" and press .

This opens the PATCH NAME Screen.



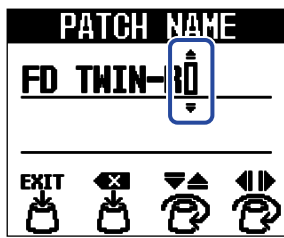

4. Turn  to move the cursor.

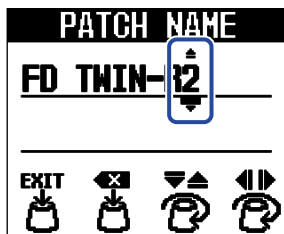

5. Turn  to insert a character.



- Press  to delete the character before the cursor.
- Press and hold  to delete all the characters.

6. Press  .

This confirms the name and reopens the [Home Screen](#).

HINT

The characters and symbols that can be used are as follows.

! % & ' + , - . = _ (space) A-Z, a-z, 0-9

Copying and saving patch memories

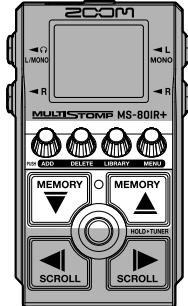

The AUTO SAVE function is ON by default. When it is OFF, effect adjustments, volume settings and other changes will not be saved automatically. Save changes manually in this case.

Patch memories can also be saved (copied) to other locations.



HINT

See "[Setting the AUTO SAVE function](#)" for details about this function.

1. Use  and  on the [Home Screen](#) to select the patch memory that you want to copy or save. (→ [Switching patch memories](#))

2. Press  to open the [MENU Screen](#).



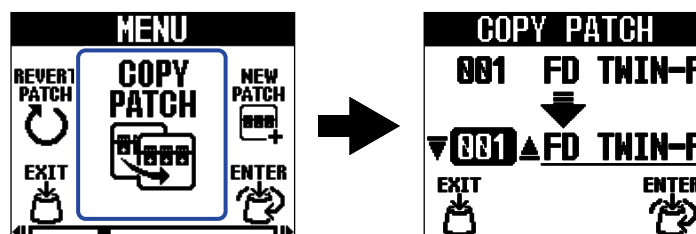

3. Turn  to select "COPY PATCH" and press .

This opens the COPY PATCH Screen.

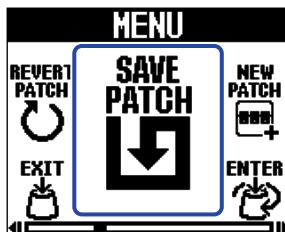

If AUTO SAVE is OFF, (→ [Setting the AUTO SAVE function](#)), "SAVE PATCH" will appear instead of "COPY PATCH". In this case, select "SAVE PATCH".



4. Turn  to select the patch memory where it will be copied or saved, and press  .
Patch memories labeled "Empty" contain no effects.

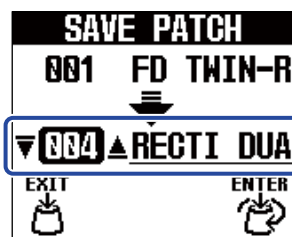

5. Press  .

This copies or saves the patch memory and reopens the [Home Screen](#).

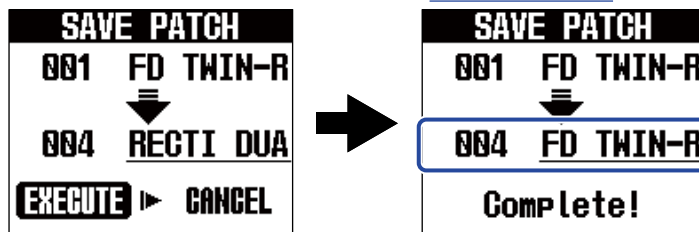

To cancel copying or saving, turn  to select "CANCEL" and press  .



HINT

If the AUTO SAVE function is OFF, patch memories will not be saved automatically. (→ [Setting the AUTO SAVE function](#))

Erasing patch memories

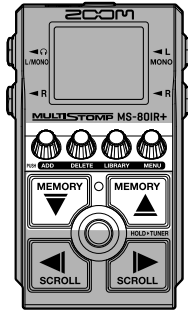
Unnecessary patch memories can be erased.



1. Use  and  on the Home Screen to select the patch memory that you want to erase.
(→ [Switching patch memories](#))

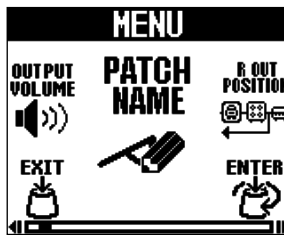

2. Press  to open the [MENU Screen](#).



3. Turn  to select "ERASE PATCH" and press .

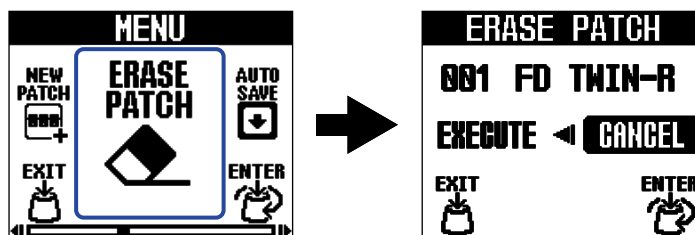

This opens the ERASE PATCH Screen.

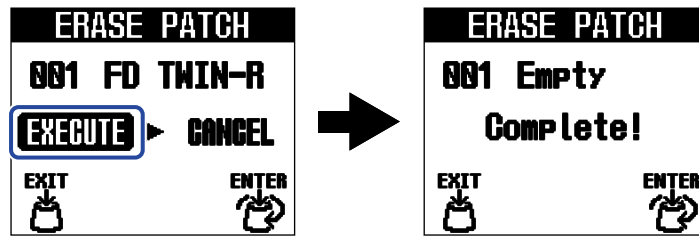

4. Turn  to select "EXECUTE" and press .





Erased patch memories will have their contents cleared and be shown as "Empty".

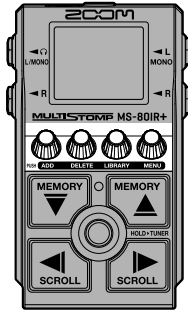

To cancel erasure, turn  to select "CANCEL" and press .

Creating patch memories



New patch memories can be created.

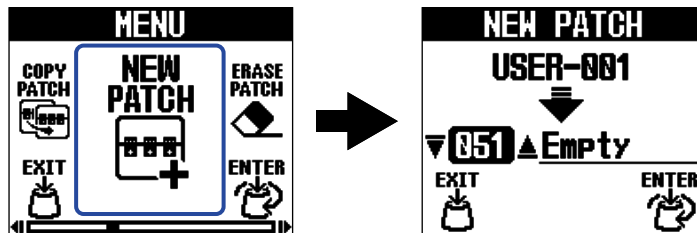

1. Press  to open the MENU Screen.

2. Turn  to select "NEW PATCH" and press  .
This opens the NEW PATCH Screen.



3. Turn  to select where to create the patch, and press  .
Patch memories labeled "Empty" contain no effects.

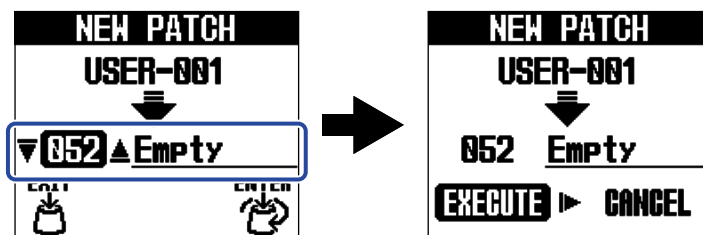

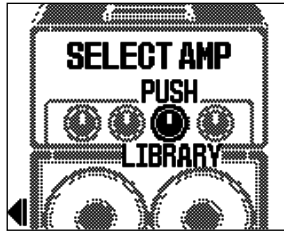

4. Press .

This creates a new patch memory and opens the SELECT AMP Screen.



Follow the instructions in ["Switching effects"](#) to assign effects and edit the patch memory.

To cancel creation, turn  to select "CANCEL" and press .

NOTE



Up to 80 patch memories can be saved. The NEW PATCH Screen will not be shown if there are no empty patch memories. Erase unnecessary patch memories to enable use. (→ [Erasing patch memories](#))

Restoring patch memories to original settings

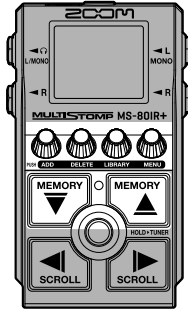
After a patch memory is changed, it can be restored to the state it was in immediately after selection or the factory default state.



1. Press  to open the [MENU Screen](#).

2. Turn  to select "REVERT PATCH" and press . This opens the REVERT PATCH Screen.

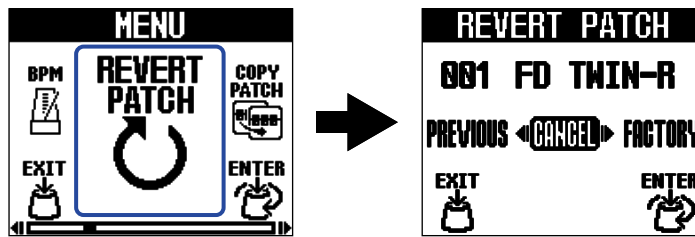

3. Turn  to select the desired state.

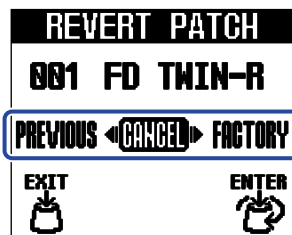



Setting	Explanation
PREVIOUS	This restores the patch memory to the state it was in immediately after selection.
FACTORY	This restores the patch memory to its factory default state.

4. Press  .



This restores the patch memory to the state selected in step 3 and reopens the [Home Screen](#).

To cancel this operation, turn  to select "CANCEL" and press  .

Using the tuner

Activating the tuner

Enable the tuner to use the MS-80IR+ to tune a guitar.

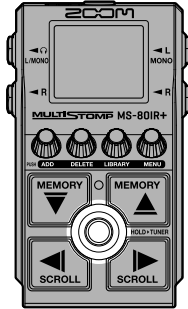

1. Press and hold .

This activates the tuner and opens the Tuner Screen.

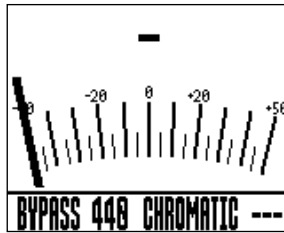

2. Play the open string that you want to tune and adjust its pitch.



- The nearest note name and pitch detuning will be shown.
- When the pitch is correct, the left and right indicators will both be shown and the display backlight will become green.

Closing the tuner

Press  when the tuner is in use to close it and reopen the previous screen.

Changing tuner settings

The standard pitch used by the tuner and the tuner type can be changed. Flat tuning is also possible.

Setting the output method

Turn  to set the output method.

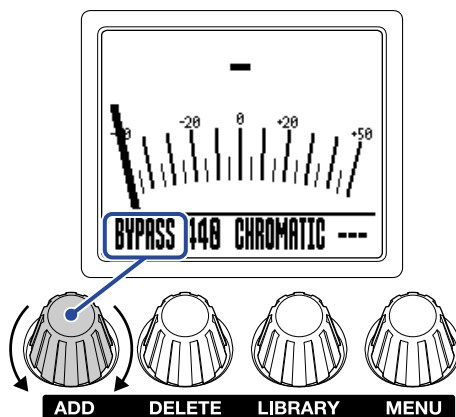

Setting	Explanation
BYPASS	The guitar sound is output with effects bypassed.
MUTE	The guitar sound is not output.

HINT

Adjusting the EQ and volume of a guitar amp, for example, is easier if the MS-80IR+ effects are bypassed.

Changing the standard pitch of the tuner

Turn  to change the standard pitch.

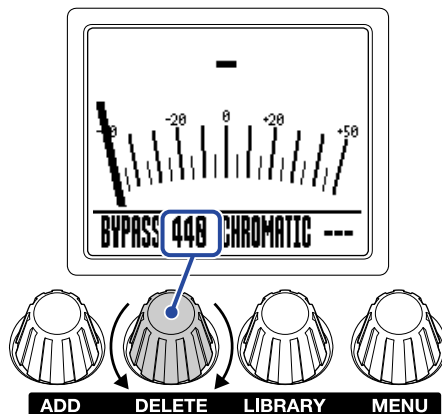

HINT

The setting range is 430–450 Hz for middle A.

Setting the tuner type

Turn  to select the tuner type.

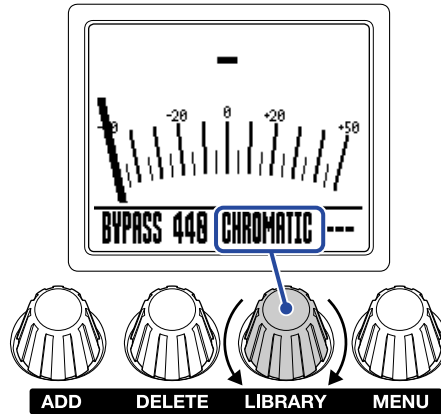

Setting	Explanation
CHROMATIC	The pitch detuning is shown according to the nearest note (in semitones).
Other tuner types	The nearest string number is shown according to the selected type, and the amount of detuning from its pitch is shown. The following tuner types can be selected.

Display	Explanation	String number/note						
		7	6	5	4	3	2	1
GUITAR	Standard guitar tuning with a 7th string	B	E	A	D	G	B	E
OPEN A	Open A tuning (open strings play A chord)	-	E	A	E	A	C#	E
OPEN D	Open D tuning (open strings play D chord)	-	D	A	D	F#	A	D
OPEN E	Open E tuning (open strings play E chord)	-	E	B	E	G#	B	E
OPEN G	Open G tuning (open strings play G chord)	-	D	G	D	G	B	D
DADGAD	Alternate tuning often used for tapping and other techniques	-	D	A	D	G	A	D

Using flat tunings

All strings can be tuned flat from ordinary tuning by 1 (b1), 2 (b2) or 3 (b3) semitones.

Turn  to change the flat tuning.

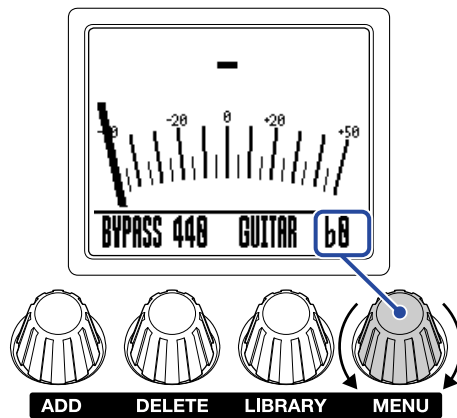

NOTE

Flat tuning cannot be used when the tuner type is CHROMATIC.

Using impulse responses (IR)

Impulse responses capture the acoustic characteristics of spaces and quantify them as data.

The characteristics of various speaker cabinets can be quantified as data and used for effects by capturing the acoustic characteristics of guitar sounds output from them when recorded by mics.

Using this effect, convincing guitar sounds can be re-created without outputting them from speaker cabinets.

Loading impulse response (IR) data

Use Handy Guitar Lab for MS-80IR+, an iOS/iPadOS app, to load impulse response data that is your own or that you acquired from a third party. (→ [Operating the MS-80IR+ from an iPhone/iPad](#))



NOTE

Impulse response data in the following format can be loaded.



- Format: WAV
- Sampling frequency: 44.1–192 kHz

Using impulse responses (IR)







Impulse responses can be assigned to patch memories.

1. Use  and  on the [Home Screen](#) to select the patch memory with the tempo that you want to adjust. (→ [Switching patch memories](#))



2. Use  and  to select STUDIO AMBIENCE.



3. Press  to open the LIBRARY Screen. Then, use , ,  and  to select the IR, and press . (→Switching effects)
IR is at the left edge of the LIBRARY Screen.
This adds the IR to the patch memory.

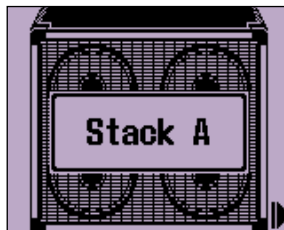

NOTE

- Either one IR or one studio ambience can be used in each patch memory.
- When an IR is selected, the cabinet of the amp model will be bypassed.

Using audio interface functions

The MS-80IR+ can be used as a 2-in/2-out audio interface.

Two channels of audio signals after effect processing can be sent from the MS-80IR+ to a computer or smartphone.

Two audio signal channels can be input from a computer or smartphone to a position after effect processing.

See [Signal flow](#) for details about input and output positions.

Installing drivers

Windows computers

1. Download the MS-80IR+ Driver from zoomcorp.com to the computer.

NOTE

The latest MS-80IR+ Driver can be downloaded from the above website.

2. Launch the installer and follow its instructions to install the MS-80IR+ Driver.

NOTE

See the Installation Guide included in the driver package for detailed installation procedures.

Mac computers, smartphones and tablets

No driver is necessary for use with Mac computers, smartphones and tablets.

Connecting to computers, smartphones and tablets

1. Use a USB cable to connect the MS-80IR+ USB port to a computer, smartphone or tablet.

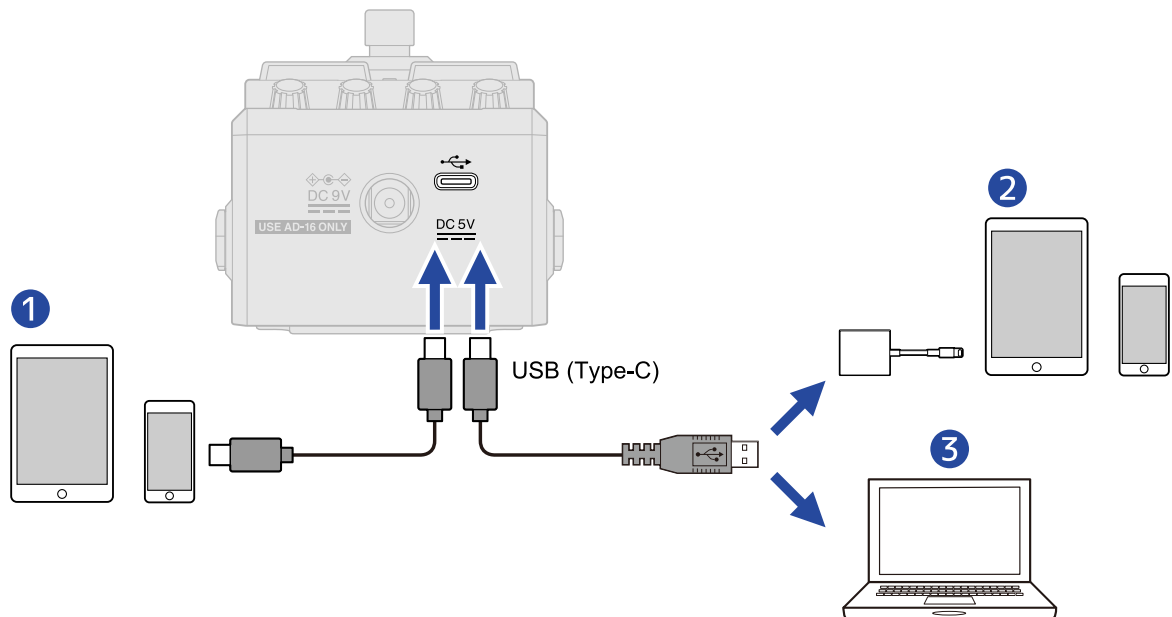

- 1 Smartphone/tablet (Android)
- 2 Smartphone/tablet (iOS/iPadOS)
- 3 Computer (Windows/Mac)

NOTE

- Use a USB (Type-C) cable that supports data transfer.
- Use a Lightning to USB 3 Camera Adapter to connect to an iOS/iPadOS device with a lightning connector.

2. Turn on the MS-80IR+ power. (→ [Turning the power on/off](#))
This will activate the connection with the smartphone or tablet.
If connecting to a computer, proceed to step 3.

3. When connecting to a computer, set “ZOOM MS Plus Series” as the sound device.

HINT

In addition to recording with your DAW software, you can enjoy performing while mixing sound played from a smartphone with the MS-80IR+ sound.

Adjusting the volume of USB audio sent to the computer

The volume (recording level) sent to the computer, smartphone or tablet can be adjusted.

1. Select "USB REC GAIN" on the [MENU Screen](#).

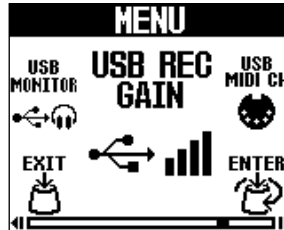

2. Turn  to adjust the recording level.
The setting value is shown on the display.



3. Press .
This confirms the setting.

4. Press .
The Home Screen will reopen.

HINT

The setting range is -15 dB to +15 dB.

Adjusting the monitoring balance for USB audio

This adjusts the balance between the output signal from the computer, smartphone or tablet and the direct signal (MS-80IR+ audio).

1. Select "USB MONITOR" on the [MENU Screen](#).

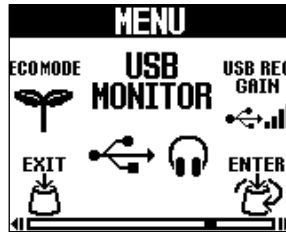

2. Turn  to adjust the monitoring balance.

The setting value is shown on the display.

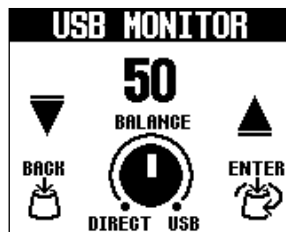

3. Press .

This confirms the setting.

4. Press .

The Home Screen will reopen.

HINT

- The setting range is 0–100. The balance will be only the direct signal when set to 0 and only the output signal from the computer, smartphone or tablet when set to 100.
 - This setting will be reset to 50 at startup.
-

Operating the MS-80IR+ from an iPhone/iPad

The MS-80IR+ can be controlled from an iPhone/iPad using Handy Guitar Lab for MS-80IR+, an iOS/iPadOS app.

NOTE

The Handy Guitar Lab for MS-80IR+ app must be installed on the iPhone/iPad beforehand. The Handy Guitar Lab for MS-80IR+ app can be downloaded from the App Store. See the operation manual for the Handy Guitar Lab for MS-80IR+ app for details about making settings and conducting operations.

1. Start the MS-80IR+.

- If using batteries, connect a cable to the L/MONO input jack.
- If using an AC adapter, connecting to the iPhone/iPad with a USB cable will start it.

2. Use a USB cable to connect the MS-80IR+ and the iPhone or iPad.

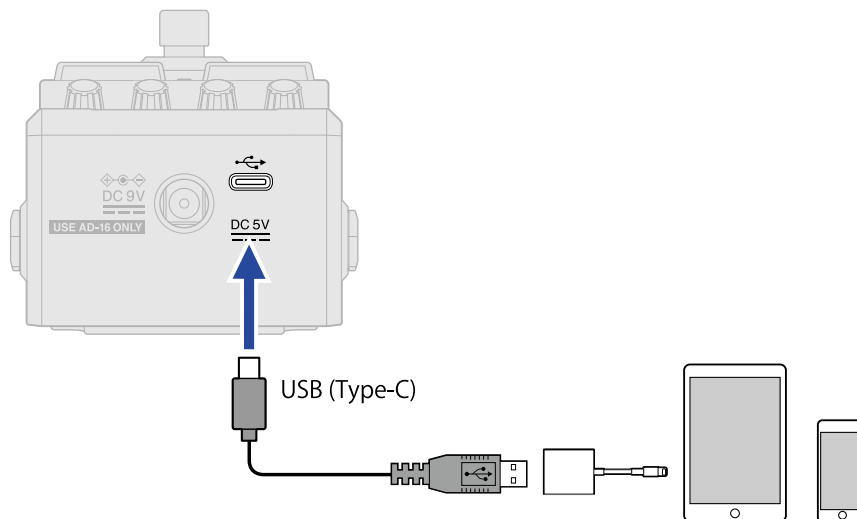



NOTE

- Use a USB (Type-C) cable that supports data transfer. The following screen will appear when the MS-80IR+ is connected.



The following screen will appear if a cable that does not support data transfer has been used. Replace the cable with one that supports data transfer.



- Use a Lightning to USB 3 Camera Adapter to connect to an iOS/iPadOS device with a lightning connector.
- The USB CONNECT Screen will appear if batteries are being used. Turn  to select "MOBILE DEVICE" as the connected device, and press .

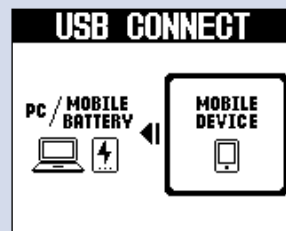

3. Launch Handy Guitar Lab for MS-80IR+ on the iPhone/iPad.

Making unit settings

Setting the AUTO SAVE function

When the AUTO SAVE function is ON, patch memories will be saved automatically when their contents are changed.

1. Select "AUTO SAVE" on the [MENU Screen](#).

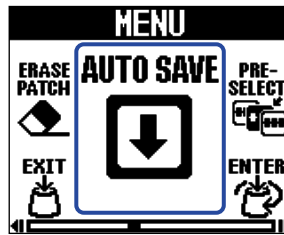

2. Turn  to switch it ON/OFF.

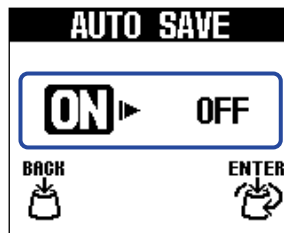

Setting	Explanation
ON	This turns on the AUTO SAVE function.
OFF	This turns off the AUTO SAVE function.

3. Press .
This confirms the setting.

4. Press .
This reopens the [Home Screen](#).

HINT

If the AUTO SAVE function is OFF, patch memories will not be saved automatically. Save them as necessary. (→ [Copying and saving patch memories](#))

Setting the sound used on the LIBRARY Screen

The sound auditioned on the [LIBRARY Screen](#) can be changed.

1. Select "LIBRARY SOUND" on the [MENU Screen](#).

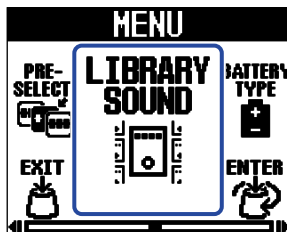

2. Turn  to switch the setting.



Setting	Explanation
SINGLE EFFECT SOUND	This enables checking the sound of just the selected effect.
PATCH MEMORY SOUND	This enables checking the sound of the entire patch memory.

3. Press  .
This confirms the setting.

4. Press  .
This reopens the [Home Screen](#).

Setting the type of batteries used

Set the type of battery used correctly so that the amount of remaining battery charge can be shown accurately.

1. Select "BATTERY TYPE" on the [MENU Screen](#).

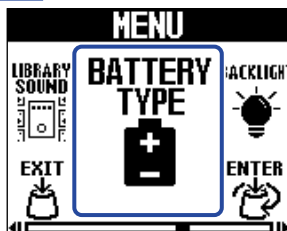

2. Turn  to set the type of battery used.

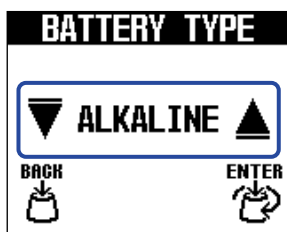

Setting	Explanation
ALKALINE	Alkaline batteries
Ni-MH	Nickel-metal hydride batteries
LITHIUM	Lithium batteries

3. Press  .

This confirms the setting.

4. Press  .

This reopens the [Home Screen](#).

Adjusting the backlight brightness

The brightness of the backlight can be adjusted. Select "NORMAL" to extend battery life.

1. Select "BACKLIGHT" on the [MENU Screen](#).

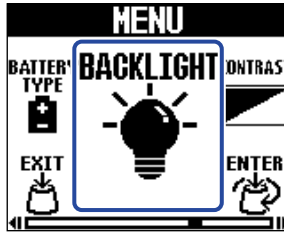

2. Turn  to adjust the backlight brightness.

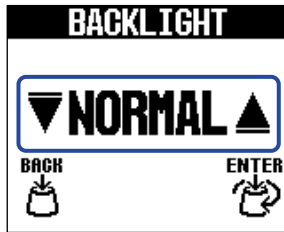

Setting	Explanation
NORMAL	This is regular brightness.
BRIGHT	This makes the backlight brighter.

3. Press  .
This confirms the setting.

4. Press  .
This reopens the [Home Screen](#).

Adjusting the display contrast

The display contrast can be adjusted.

1. Select "CONTRAST" on the [MENU Screen](#).

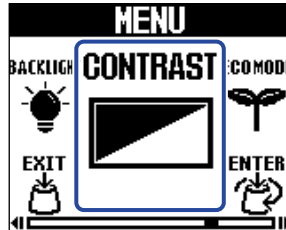

2. Turn  to adjust the display contrast.

The setting value is shown on the display.

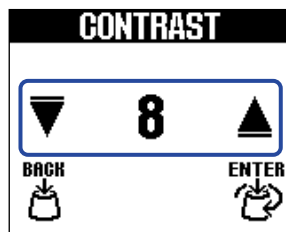

3. Press  .

This confirms the setting.

4. Press  .

This reopens the [Home Screen](#).

Setting the ECO MODE

This function can be used to turn the power off automatically if unused for 10 hours.

1. Select "ECO MODE" on the [MENU Screen](#).

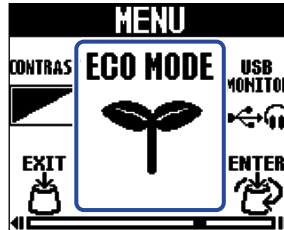

2. Turn  to switch it ON/OFF.

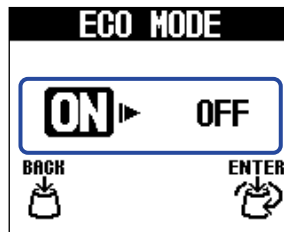

Setting	Explanation
ON	The power will automatically turn off if unused for 10 hours.
OFF	This disables ECO MODE.

3. Press .

This confirms the setting.

4. Press .

This reopens the [Home Screen](#).

Setting the channel used to receive USB MIDI

The MS-80IR+ supports program changes by USB MIDI, and the channel used for receiving them can be set.

1. Select "USB MIDI CH" on the [MENU Screen](#).

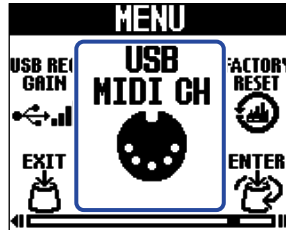

2. Turn  to switch the setting.

Set it to "OMNI" to receive on all channels.

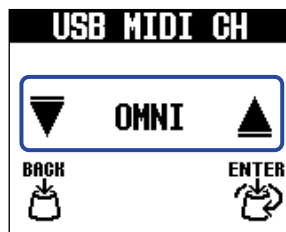

3. Press .

This confirms the setting.

4. Press .

This reopens the [Home Screen](#).

Managing the firmware

Checking the firmware version

The version of the firmware used by the MS-80IR+ can be checked.

1. Select "VERSION" on the [MENU Screen](#).

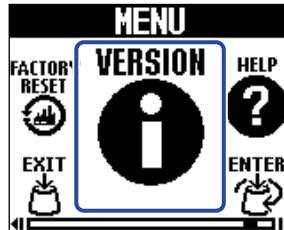

2. Check the version on the VERSION Screen.
This shows the firmware and preset versions.

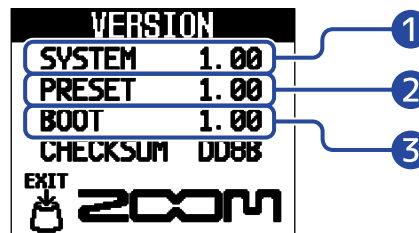

- 1 MS-80IR+ firmware version
- 2 Preset version
- 3 Boot version

3. Press  .

This reopens the [Home Screen](#).

Updating the firmware

The MS-80IR+ firmware can be updated to the latest version.

The latest firmware can be downloaded from the ZOOM website (zoomcorp.com/help/ms-80irplus).

Restoring factory default settings

Settings can be restored to the factory defaults.

1. Select "FACTORY RESET" on the [MENU Screen](#).

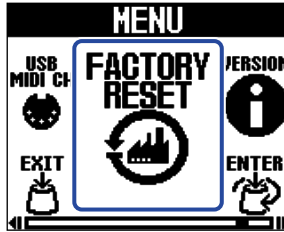

2. Turn  to select "YES".



3. Press .

Resetting will be executed, restoring default settings.



NOTE

Resetting will overwrite all settings, including patch memories, with their factory defaults. Be certain before using this function.

HINT

To cancel resetting, select "NO" in step 2.

Checking the latest MS-80IR+ information

A 2D code for help related to the MS-80IR+ can be shown on its display.

1. Select "HELP" on the [MENU Screen](#).

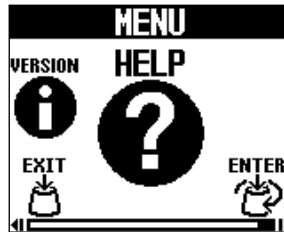

2. Use a smartphone or tablet, for example, to read the 2D code shown on the HELP Screen.



zoomcorp.com/help/ms-80irplus

3. Press  .

This reopens the [Home Screen](#).

Appendix

Troubleshooting

The unit will not power on

- If using batteries, connect a cable to the L/MONO input jack. (→ [Turning the power on/off](#))
- Check the connections. (→ [Making connections](#))
- If the ON/OFF indicator blinks and it will not start, update the firmware. (→ [Updating the firmware](#))

There is no sound or output is very quiet

- Check the connections. (→ [Making connections](#))
- Adjust the levels of the effects. (→ [Adjusting effect parameters](#))
- Adjust the output volume. (→ [Adjusting the overall output level](#))
- Confirm that the tuner output is not set to "MUTE". (→ [Setting the output method](#))

There is a lot of noise

- Confirm that an instrument cable is not the cause.
- Use a genuine ZOOM AC adapter. (→ [Making connections](#))

Batteries lose their charge quickly

Making the following settings could increase the battery operation time.

- Set the type of battery used correctly. (→ [Setting the type of batteries used](#))
- Set the display backlight to "NORMAL". (→ [Adjusting the backlight brightness](#))
- Due to their characteristics, using nickel metal hydride batteries (especially high-capacity ones) or lithium batteries should enable longer use than alkaline batteries when power consumption is high.

Volume is low when recorded in a DAW

- Check the recording level setting. (→ [Adjusting the volume of USB audio sent to the computer](#))

Sound from the R output jack is strange

- Check the R OUT POSITION setting. (→ [Changing the R channel signal output position](#))

Specifications

Maximum number of simultaneous effects		1 amplifier, 1 studio ambience and 1 other effect
User patch memories		80
Sampling frequency		44.1 kHz
A/D conversion		24-bit 128× oversampling
D/A conversion		24-bit 128× oversampling
Signal processing		32-bit
Frequency response		20 Hz – 20 kHz (+0.5 dB/–0.5 dB) (when 10kΩ load)
Display		160×128 dot-matrix LCD
Inputs	L/R	Standard mono phone jacks Rated input level: –20 dBu Input impedance (line): 470 kΩ
Outputs	L/MONO/headphone	Standard stereo phone jack (combined line/headphone) Maximum output level: +7.2 dBu (when output impedance 10 kΩ or higher) Maximum output level: 20 mW + 20 mW (when 32Ω load)
	R	Standard mono phone jacks Maximum output level: +7.2 dBu (when output impedance 10 kΩ or higher)
Input S/N		122 dB
Noise floor (residual noise)	L/R	–100 dBu
Power		AC adapter: 9V DC 500mA center negative (ZOOM AD-16) 2 AA batteries (alkaline, lithium or rechargeable NiMH batteries)
Estimated operation times using batteries	<ul style="list-style-type: none"> • These values are approximate. • Battery operation times were determined using in-house testing methods. They will vary greatly according to use conditions. 	Alkaline batteries: about 3.5 hours (about 3 hours using stereo input) NiMH batteries (1900 mAh): about 4 hours (about 3.5 hours using stereo input) Lithium batteries: about 7.5 hours (about 6.5 hours using stereo input)
USB		Port: USB 2.0 Type-C / Supported cable type: Type-C Handy Guitar Lab: USB 1.1 Full Speed Audio interface: USB 2.0 Full Speed, 44.1kHz/32-bit, 2 in, 2 out <ul style="list-style-type: none"> • Use a USB cable that supports data transfer. USB bus power is supported.

Dimensions	133 mm (D) × 79 mm (W) × 61 mm (H)
Weight	369 g (excluding batteries) 416 g (including batteries)

Note: 0 dBu = 0.775 V

MIDI implementation chart

[MultiStomp]

Model : MS-80IR+

Date : June. 1, 2024

Version :1.00

Function		Transmitted	Recognized	Remarks
Basic Channel	Default Changed	x x	1 - 16 1 - 16	Memorized
Mode	Default Message Altered	x x *****	x x *****	
Note Number	True Voice	x *****	x *****	
Velocity	Note ON Note OFF	x x	x x	
After Touch	Keys Ch's	x x	x x	
Pitch Bend		x	x	
Control Change		x	x	
Program Change	True Number	x *****	o 0 - 80 0 - 80	
System Exclusive		x	x	
System Common	Song Position Song Select Tune Request	x x x	x x x	
System Real Time	Clock Commands	x x	x x	
Aux Messages	Local ON/OFF All Notes OFF Active Sense System Reset	x x x x	x x x x	
Notes				

Mode 1 : OMNI ON, POLY
Mode 3 : OMNI OFF, POLY

Mode 2 : OMNI ON, MONO
Mode 4 : OMNI OFF, MONO

o : Yes
x : No



ZOOM CORPORATION

4-4-3 Kanda-surugadai, Chiyoda-ku, Tokyo 101-0062 Japan

zoomcorp.com