

# ZOOM®

# B6

## Multi-Effects Processor



# Patch Memory List

### Preset Ver. 1.00

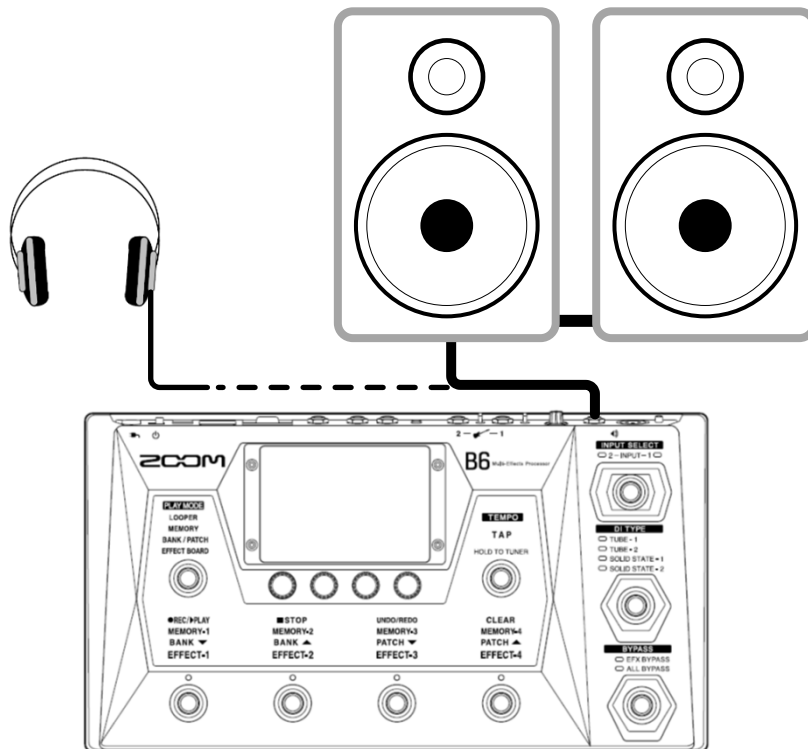
These preset patch memories will provide optimal tone when connected to a PA system. Try them with the B6 connected to a PA system, powered monitor speakers or headphones.



To use this preset patch memory when connected to a bass amp, turn off both the CABINET

( or  icon) and IR . Then adjust the EQ of the bass amp as desired.

If the bass input has a lot of noise, use noise reduction .

©2021 ZOOM CORPORATION

Copying or reprinting this manual in part or in whole without permission is prohibited.

Product names, registered trademarks and company names in this document are the property of their respective companies. All trademarks and registered trademarks in this document are for identification purposes only and are not intended to infringe on the copyrights of their respective owners.

This document cannot be displayed properly on black-and-white displays.

# Contents

BANK A : BassAmps 1	3
BANK B : BassAmps 2	4
BANK C : BassAmps 3	5
BANK D : LEGENDS	6
BANK E : JAZZ&FUNK	7
BANK F : POP MUSIC	8
BANK G : ROCK	9
BANK H : UK ROCK	10
BANK I : HR&METAL	11
BANK J : SYNTH 1	12
BANK K : SYNTH 2	13
BANK L : CLEAN&DRV	14
BANK M : DRIVE	15
BANK N : FUZZ&OCT	16
BANK O : OCTAVER	17
BANK P : FILTER&WAH	18
BANK Q : FUNKY EFX	19
BANK R : MODULATION	20
BANK S : TREMOLO	21
BANK T : PITCH&SYN	22
BANK U : DELAY 1	23
BANK V : DELAY 2	24
BANK W : SFX	25
BANK X : Aco.Basic	26
BANK Y : Aco.Bow&FX	27

# BANK A : BassAmps 1

## 001 : SVT Drive

This all-around rock sound combines the impulse responses of an AMPG SVT with an 8x10" cabinet.

PRE 1073

Gain:40  
Bass-F:220  
Bass:0  
MID-F:1.6K  
MID:0  
TRBL-F:16K  
Treble:34  
Vol:67

AMPG SVT

Bass:6.5  
MID-F:250  
MID:0.0  
Treble:0.0  
Gain:36  
Ultra:HI  
VOL:76

IR

LO:50  
HI:50  
BAL:100  
VOL:-18.0

LEVEL 40

## 002 : Fat B-MAN

This heavy and warm tube amp sound combines BMAN100 with FD-B4x12.

EP STOMP

Gain:36  
Bass:0  
Treble:-4  
VOL:40

BMAN100

Bass:52  
MID-F:220  
MID:55  
Treble:67  
Gain:58  
Deep:OFF  
VOL:49

FD-B 4x12

DYN20:65  
DYN57:50  
Bottom:55  
BAL:100

LEVEL 73

## 003 : SVT Clean

This clean sound combines AMPG SVT and a half-stack cabinet with a tweeter.

BLACK OPT

Comp:30  
Lo:50  
Hi:50  
VOL:68

AMPG SVT

Bass:0.5  
MID-F:200  
MID:2.0  
Treble:5.0  
Gain:24  
Ultra:HI  
VOL:80

IR

LO:52  
HI:42  
BAL:80  
VOL:-18.0

LEVEL 100

## 004 : Natural AG

This natural and powerful clean sound combines AG750 and AG4x10TW.

SOLID PRE

Gain:40  
HMNCS:47  
LoType:SHELF  
LoFREQ:120  
Lo:-15  
HIFREQ:3.5K  
Hi:-6  
Vol:85

AG 750

Bass:53  
MID:48  
Treble:50  
Gain:35  
BRGHT:ON  
Deep:OFF  
VOL:76

AG 4x10 TW

DYN20:56  
DYN57:48  
Bottom:50  
BAL:100

LEVEL 100

# BANK B : BassAmps 2

## 005 : SMR Slap

Combining SMR400 and a half-stack cabinet with a tweeter, this clean sound is good for slapping.

THRSH:-15  
Ratio:4.0  
Knee:HARD  
VOL:62

Bass:7.5  
MID-F:800  
MID:4.0  
Treble:0.0  
Gain:65  
ENHNC:0  
VOL:43

DYN20:50  
DYN57:72  
Bottom:65  
BAL:90

LEVEL  
100

## 006 : Warm AC370

This warm sound combines AC370 with a uniquely-constructed cabinet that has just a single 18" speaker.

FREQ:200  
Lo:26  
Hi:46  
VOL:70

Bass:55  
MID-F:350  
MID:45  
Treble:74  
Gain:14  
BRGHT:OFF  
VOL:45

LO:65  
HI:75  
BAL:65  
VOL:-5.5

LEVEL  
100

## 007 : Sunny DRV

Combining SUN CB and SN2x15, this powerful drive sound is good for 70s and 80s rock styles.

Input:40  
Ratio:4.1  
REL:20  
Output:30

Gain:32  
Tone:50  
BAL:79  
VOL:35

Input:NORMAL  
Bass:50  
MID:50  
Treble:60  
Dist:70  
Color:OFF  
Hi Bst:OFF  
VOL:40

DYN20:65  
DYN57:70  
Bottom:50  
BAL:100

LEVEL  
115

## 008 : EBH Slap

Combining EBH360 and a half-stack cabinet with a tweeter, this bright sound is good for slapping.

Comp:60  
LoTHR:67  
HiTHR:25  
VOL:33

Bass:3.0  
MID-F:2.0K  
MID:1.5  
Treble:0.0  
BRGHT:22  
Drive:15  
VOL:65  
CHARA:OFF

DYN20:52  
DYN57:42  
Bottom:55  
BAL:50

LEVEL  
100

# BANK C : BassAmps 3

## 009 : Mark Tone

This combo amp sound with a distinctive mid range combines Mini MarkB and MkB2x8TW.

Gain:50  
Bass-F:55  
Bass:0  
MID-F:1.6K  
MID:21  
TRBL-F:10K  
Treble:0  
Vol:60

Gain:62  
VNTG:49  
Shape:55  
VOL:61

DYN20:51  
DYN57:83  
Bottom:50  
BAL:100

LEVEL  
92

## 010 : Classic TE

Combining TE400SX and TE4x10, this clean sound is good for playing rock and fusion.

Comp:70  
LoTHR:50  
HiTHR:50  
VOL:25

Style:FINGER  
Bass:0.5  
MID:1.5  
Treble:5.5  
Gain:57  
Shape:2  
VOL:50

DYN20:50  
DYN57:50  
Bottom:50  
BAL:49

LEVEL  
80

## 011 : Flip Tone

This vintage tube sound, which is good for soul and Motown styles, combines FlipTop and AM1x15.

Gain:40  
Nature:45  
Blend:61  
VOL:36

BRGHT:OFF  
Treble:4.0  
MID:5.5  
Bass:8.5  
Gain:35  
Ultra:OFF  
VOL:70

DYN20:40  
DYN57:70  
Bottom:55  
BAL:71

Input:28  
Ratio:4:1  
REL:31  
Output:39

LEVEL  
69

## 012 : Poly Combo

This combo amp sound, which is good for jazz, combines the impulse response of a room mic with Monotone.

OCT1:30  
OCT2:0  
MOD:0  
Dry:86

Bass:40  
MID:68  
Treble:35  
PRSN:0  
MODE:NORMAL  
VOL:50

LO:50  
HI:50  
BAL:100  
VOL:-17.6

LEVEL  
75

# BANK D : LEGENDS

## 013 : Portrait

This sound is inspired by a fusion bassist famous for playing fretless bass and using harmonics.

Gain:39  
FLTR:31  
VOL:67  
DryMx:60

Depth:85  
Speed:40  
Tone:40  
Mix:76

Bass:53  
MID:73  
Treble:50  
PRNC:21  
MODE:NORMAL  
VOL:49

DYN20:45  
DYN57:48  
Bottom:50  
BAL:34

LEVEL  
83

## 014 : Liverpool

This sound is inspired by a legendary rock band formed in Liverpool in the 60s.

Gain:50  
Bass-F:55  
Bass:-10  
MID-F:700  
MID:3  
TRBL-F:10K  
Treble:-1  
Vol:60

Gain:62  
VNTG:50  
Shape:40  
VOL:37

LO:50  
HI:50  
BAL:80  
VOL:-6.9

LEVEL  
74

## 015 : GZR Wah

This dark and powerful wah sound is inspired by the bassist of an English band that was a driving force at the dawn of heavy metal.

Input:NORMAL  
Bass:65  
MID:44  
Treble:53  
Dist:10  
Color:OFF  
Hi Bst:OFF  
VOL:40

DYN20:50  
DYN57:50  
Bottom:60  
BAL:100

Gain:18  
FLTR:62  
VOL:59  
DryMx:85

Sense:4  
RESO:2  
Dry:50  
VOL:80

LEVEL  
88

## 016 : LarryJet

This jet phase sound is inspired by the funk bassist who is said to have created slap playing.

Mode:4  
Rate:31  
RESO:2  
VOL:100

Bass:50  
MID:42  
Treble:78  
Gain:49  
BRGHT:ON  
Deep:OFF  
VOL:67

LO:44  
HI:60  
BAL:80  
VOL:-12.7

LEVEL  
48

# BANK E : JAZZ&FUNK

## 017 : MM Clean

This clean slap sound is inspired by a New York fusion bassist.

LEVEL: 88

Input:28 Ratio:4:1 REL:15 Output:42	Shift:-12 Tone:90 Wet:55 Dry:80	Bass:15 Treble:0 VOL:78 ON/OFF:LATCH	Depth:24 Rate:14 LoCut:280 Mix:23	50:0.0 120:2.0 400:-2.5 500:-1.0 800:3.5 4.5k:3.0 10k:4.0 VOL:80
--	--	---	--	---

## 018 : ModernJazz

This modern jazz fusion sound features a heavy midrange.

LEVEL: 100

Sense:5 ATTCK:SLOW Tone:59 VOL:60	Gain:50 Bass-F:220 Bass:16 MID-F:700 MID:23 TRBL-F:10K Treble:-21 Vol:49	OCT1:65 OCT2:8 MOD:25 Dry:86	Depth:75 Rate:27 LoCut:180 Mix:76	PreD:70 Decay:11 Tone:4 Mix:18
--	---	---------------------------------------	--	---

## 019 : BootFunk

This auto-wah sound is inspired by a funk bassist known for his star-shaped sunglasses and bass guitar.

LEVEL: 65

Boost:26 Tone:55 Fuzz:15 Dry:85	Sense:1 RESO:6 Dry:70 VOL:65	Bass:2.0 MID-F:630 MID:1.0 Treble:9.0 Gain:24 Ultra:OFF VOL:55	DYN20:60 DYN57:55 Bottom:65 BAL:100
--	---------------------------------------	--	--

## 020 : Wonderful

The left-hand keyboard playing of an American singer-songwriter famous worldwide is the inspiration for this funky synthesizer sound.

LEVEL: 60

FREQ:5 Range:8 Decay:72 RESO:6 Wave:SAW Tone:7 BAL:80 VOL:80	Oct:50 Lo:0 Hi:0 Dry:80	Gain:50 Bass-F:55 Bass:12 MID-F:1.6K MID:0 TRBL-F:10K Treble:0 Vol:50	Drive:7 Lo:50 Hi:60 VOL:50
---	----------------------------------	--	-------------------------------------

# BANK F : POP MUSIC

## 021 : Pop Clean

This clean sound is perfect for smooth pop bass lines.

EBH 360

MB COMP

HALL

LEVEL 73

Bass:1.5  
MID-F:400  
MID:-1.0  
Treble:2.5  
BRGHT:36  
Drive:20  
VOL:50  
CHARA:OFF

Comp:70  
LoTHR:50  
HiTHR:50  
VOL:43

PreD:35  
Decay:7  
Mix:15  
Tail:OFF

## 022 : Pop Drive

This all around drive sound is good for pop music.

RC BOOST

BASS DRV

MONOTONE

SN 2x15

LEVEL 76

Gain:33  
Bass:50  
Treble:49  
VOL:41

Bass:48  
Treble:46  
PRSN:29  
Blend:48  
Gain:56  
VOL:48  
MID-F:1.0K  
MID:61

Bass:56  
MID:48  
Treble:50  
PRSN:13  
MODE:NORMAL  
VOL:50

DYN20:53  
DYN57:62  
Bottom:60  
BAL:100

## 023 : 80' Studio

This 80s-style studio sound for playing with a pick uses slapback delay.

PRE 1073

160 COMP

BASS GEQ

DELAY

LEVEL 63

Gain:50  
Bass-F:55  
Bass:3  
MID-F:1.6K  
MID:0  
TRBL-F:10K  
Treble:0  
Vol:65

THRSH:-22  
Ratio:4.0  
Knee:HARD  
VOL:89

50:0.0  
120:0.0  
400:0.0  
500:0.0  
800:4.0  
4.5k:2.5  
10k:0.0  
VOL:80

Time:63  
F.B:0  
Mix:32  
Tail:OFF

## 024 : Slap 42

This bright slap sound with a notable chorus effect is inspired by a bassist and vocalist who plays with a distinctive high-speed slapping "machine-gun style".

PRE 1073

LMT-76

TE 400

CLONE CHORUS

LEVEL 32

Gain:50  
Bass-F:55  
Bass:22  
MID-F:700  
MID:-1.4  
TRBL-F:10K  
Treble:24  
Vol:53

Input:40  
Ratio:8:1  
REL:20  
Output:47

Style:SLAP  
Bass:0.5  
MID:1.5  
Treble:8.0  
Gain:20  
Shape:2  
VOL:60

Depth:2  
Rate:23  
Tone:100  
Mix:100



# BANK G : ROCK

## 025 : M's Milk

This slap sound is inspired by the fourth album of a rock band that came together in Los Angeles in 1983.

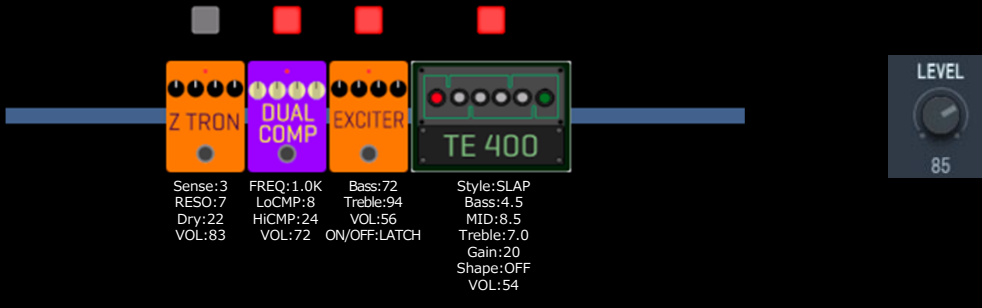

Diagram of a pedalboard for the '025 : M's Milk' preset. It features four pedals: Z TRON (orange), DUAL COMP (purple), EXCITER (orange), and TE 400 (green). A LEVEL knob is set to 85. Three red indicator lights are shown above the pedals.

Sense:3  
RESO:7  
Dry:22  
VOL:83

FREQ:1.0K  
LoCMP:8  
HiCMP:24  
VOL:72

Bass:72  
Treble:94  
VOL:56  
ON/OFF:LATCH

Style:SLAP  
Bass:4.5  
MID:8.5  
Treble:7.0  
Gain:20  
Shape:OFF  
VOL:54

LEVEL  
85

## 026 : Blue Stone

This clean sound perfect for finger-playing is inspired by an American three-piece blues-rock band from Texas.

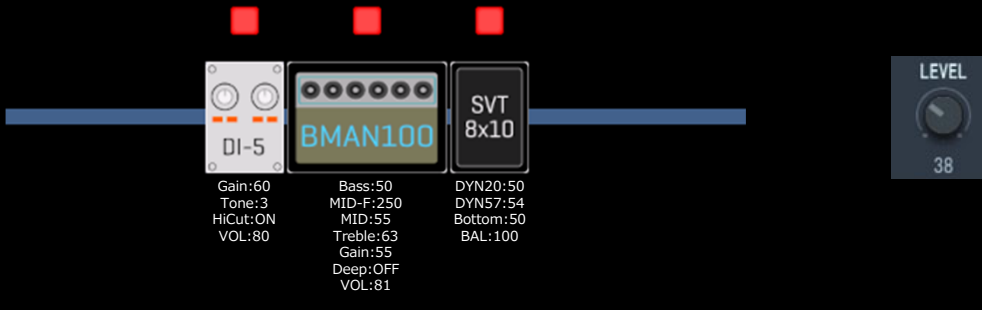

Diagram of a pedalboard for the '026 : Blue Stone' preset. It features three pedals: DI-5 (grey), BMAN100 (blue), and SVT 8x10 (black). A LEVEL knob is set to 38. Three red indicator lights are shown above the pedals.

Gain:60  
Tone:3  
HiCut:ON  
VOL:80

Bass:50  
MID-F:250  
MID:55  
Treble:63  
Gain:55  
Deep:OFF  
VOL:81

DYN20:50  
DYN57:54  
Bottom:50  
BAL:100

LEVEL  
38

## 027 : RockSlap

This drive sound is perfect for slapping in rock styles. This can punch through even in aggressive songs.

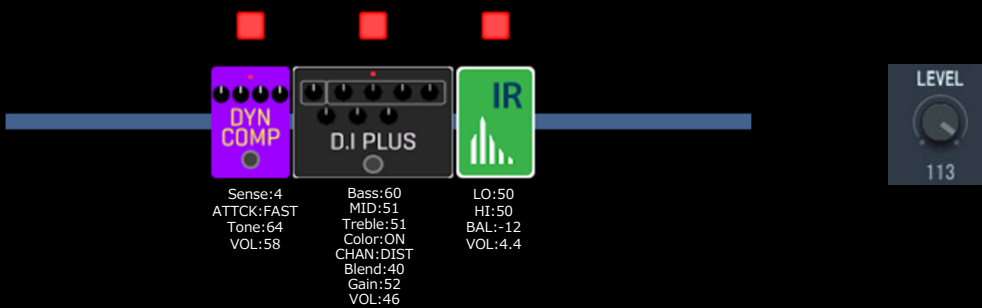

Diagram of a pedalboard for the '027 : RockSlap' preset. It features three pedals: DYN COMP (purple), D.I PLUS (grey), and IR (green). A LEVEL knob is set to 113. Three red indicator lights are shown above the pedals.

Sense:4  
ATTCK:FAST  
Tone:64  
VOL:58

Bass:60  
MID:51  
Treble:51  
Color:ON  
CHAN:DIST  
Blend:40  
Gain:52  
VOL:46

LO:50  
HI:50  
BAL:-12  
VOL:4.4

LEVEL  
113

## 028 : ProgBass

This sound is inspired by a Canadian bassist and vocalist known for his distinctive progressive playing.

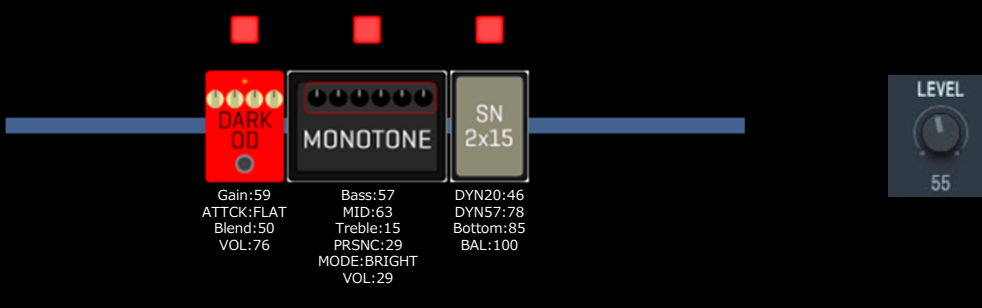

Diagram of a pedalboard for the '028 : ProgBass' preset. It features three pedals: DARK OD (red), MONOTONE (grey), and SN 2x15 (grey). A LEVEL knob is set to 55. Three red indicator lights are shown above the pedals.

Gain:59  
ATTCK:FLAT  
Blend:50  
VOL:76

Bass:57  
MID:63  
Treble:15  
PRSN:29  
MODE:BRIGHT  
VOL:29

DYN20:46  
DYN57:78  
Bottom:85  
BAL:100

LEVEL  
55

# BANK H : UK ROCK

## 029 : The Ox Rox

This drive sound is inspired by the bassist known as The Ox.

**DJENT PREAMP**

- Bass:48
- L-MID:71
- H-MID:67
- Treble:50
- Hi Bst:OFF
- LoCut:40
- Gain:14
- VOL:40

**SUN CB**

- Input:NORMAL
- Bass:50
- MID:50
- Treble:50
- Dist:64
- Color:OFF
- Hi Bst:OFF
- VOL:40

**SN 2x15**

- DYN20:50
- DYN57:50
- Bottom:60
- BAL:100

**LEVEL**

60

## 030 : Synchroniz

This sound with a floating feel is inspired by a track from the 1983 fifth album from an English trio known for adding elements of reggae to rock.

**KICK FLANGER**

- PreD:6
- Depth:40
- Rate:20
- ON/OFF:LATCH
- RESO:60
- Mix:80
- RST-F:50

**AMPG SVT**

- Bass:-1.5
- MID-F:200
- MID:1.0
- Treble:-1.5
- Gain:30
- Ultra:OFF
- VOL:71

**IR**

- LO:45
- HI:36
- BAL:80
- VOL:-18.0

**ROOM**

- PreD:10
- Decay:8
- Mix:58
- Tail:OFF

**LEVEL**

60

## 031 : Heartbreak

This sound is inspired by a famous song from the second album of a hard rock band that debuted in 1968 in England.

**NYC MUFF**

- SUSTN:20
- Tone:55
- BAL:69
- VOL:39

**BASS OD**

- Gain:0
- Tone:20
- BAL:50
- VOL:60

**CLONE CHORUS**

- Depth:2
- Rate:38
- Tone:100
- Mix:100

**AC 370**

- Bass:48
- MID-F:220
- MID:58
- Treble:58
- Gain:40
- BRGHT:OFF
- VOL:45

**AC 1x18**

- DYN20:60
- DYN57:57
- Bottom:44
- BAL:100

**LEVEL**

50

## 032 : RoundAB

This sound is inspired by the first track by an English prog rock band on their fourth album, released in 1971.

**VOODOO -B**

- Gain:35
- Tone:58
- Blend:85
- VOL:85

**SUN CB**

- Input:NORMAL
- Bass:64
- MID:82
- Treble:31
- Dist:50
- Color:OFF
- Hi Bst:OFF
- VOL:46

**IR**

- LO:50
- HI:48
- BAL:80
- VOL:-18.0

**LEVEL**

85

# BANK I : HR&METAL

## 033 : 3 Finger

This drive sound suited for lead playing is inspired by a famous rock bassist known for tapping and three-finger playing.

**DYN COMP**  
Sense:7  
ATTCK:FAST  
Tone:55  
VOL:50

**D.I PLUS**  
Bass:63  
MID:32  
Treble:8  
Color:ON  
CHAN:DIST  
Blend:50  
Gain:0  
VOL:63

**BASS TS DRIVE**  
Gain:97  
Tone:32  
BAL:49  
VOL:82

**AMPG SVT**  
Bass:4.5  
MID-F:400  
MID:-1.0  
Treble:0.0  
Gain:23  
Ultra:OFF  
VOL:99

**LEVEL**  
97

## 034 : Wrathchild

This sound is inspired by a heavy metal bassist known for distinctive percussive finger-playing.

**DUAL COMP**  
FREQ:900  
LoCMP:15  
HiCMP:30  
VOL:74

**RC BOOST**  
Gain:26  
Bass:54  
Treble:54  
VOL:38

**BMAN100**  
Bass:50  
MID-F:630  
MID:76  
Treble:84  
Gain:55  
Deep:OFF  
VOL:50

**TE 4x10**  
DYN20:50  
DYN57:68  
Bottom:50  
BAL:78

**LEVEL**  
85

## 035 : EdgyBalls

This edgy slash metal sound is perfect for playing with a pick.

**BMAN100**  
Bass:40  
MID-F:800  
MID:60  
Treble:70  
Gain:65  
Deep:OFF  
VOL:55

**SVT 8x10**  
DYN20:50  
DYN57:50  
Bottom:50  
BAL:100

**DARK PRE**  
Bass:30  
L-MID:35  
H-MID:45  
Treble:40  
Blend:80  
Gain:81  
VOL:65  
Boost:OFF

**LEVEL**  
65

## 036 : Djent Bass

This Djent sound is metallic and crisp.

**ZNR**  
DETCT:EFXIN  
Depth:100  
THRSH:75  
Decay:15

**DARK OD**  
Gain:60  
ATTCK:BOOST  
Blend:60  
VOL:75

**MONOTONE**  
Bass:72  
MID:40  
Treble:50  
PRSN:10  
MODE:BRIGHT  
VOL:39

**SN 2x15**  
DYN20:50  
DYN57:42  
Bottom:75  
BAL:100

**LEVEL**  
45

# BANK J : SYNTH 1

## 037 : FunkyVoice

This creates a sound like a funky bass synth.

**Z-SYNTH**  
 FREQ:3  
 Range:8  
 Decay:72  
 RESO:18  
 Wave:SAW  
 Tone:8  
 BAL:100  
 VOL:18

**MONOTONE**  
 Bass:52  
 MID:70  
 Treble:63  
 PRSNC:28  
 MODE:NORMAL  
 VOL:44

**SN 2x15**  
 DYN20:60  
 DYN57:70  
 Bottom:55  
 BAL:100

**LEVEL**  
80

## 038 : Synth Bass

This thick bass synthesizer sound uses an octaver effect.

**Z-SYNTH**  
 FREQ:6  
 Range:7  
 Decay:66  
 RESO:13  
 Wave:SAW  
 Tone:7  
 BAL:86  
 VOL:80

**BASS ANALOG OCTAVE**  
 OCT1:26  
 OCT2:0  
 MOD:10  
 Dry:80

**MONOTONE**  
 Bass:60  
 MID:50  
 Treble:55  
 PRSNC:60  
 MODE:NORMAL  
 VOL:26

**SN 2x15**  
 DYN20:50  
 DYN57:60  
 Bottom:65  
 BAL:100

**LEVEL**  
49

## 039 : Low Devil

This bass synth sounds like crawling through dirt.

**DYN COMP**  
 Sense:6  
 ATTCK:SLOW  
 Tone:50  
 VOL:50

**BASS STANDARD SYNTH**  
 Mode:DOWN  
 Sense:50  
 ATTCK:50  
 Range:56  
 RESO:58  
 Oct:80  
 BAL:100  
 VOL:80

**HALL**  
 PreD:14  
 Decay:9  
 Mix:20  
 Tail:OFF

**LEVEL**  
80

## 040 : FM Bass

This creates a sound like an 80s digital bass synth. This is perfect for tight repetitive upbeat bass lines.

**160 COMP**  
 THRSH:-22  
 Ratio:7.9  
 Knee:HARD  
 VOL:80

**Z-SYNTH**  
 FREQ:4  
 Range:14  
 Decay:33  
 RESO:2  
 Wave:SAW  
 Tone:10  
 BAL:70  
 VOL:53

**DI-5**  
 Gain:66  
 Tone:OFF  
 HiCut:ON  
 VOL:40

**BRIGHT ROOM**  
 PreD:5  
 Decay:6  
 Tone:7  
 Mix:61

**LEVEL**  
43

# BANK K : SYNTH 2

## 041 : Chameleon

This synth sound suitable for jazz-funk uses a combination of Z-Syn and A-Filter.

Input:29  
Ratio:4:1  
REL:20  
Output:38

FREQ:7  
Range:6  
Decay:72  
RESO:18  
Wave:SAW  
Tone:7  
BAL:64  
VOL:80

Mode:UP  
Sense:8  
Peak:3  
Dry:68

Depth:19  
Rate:36  
LoCut:120  
Mix:18

LEVEL  
35

## 042 : JustBeatIt

This synth sound is inspired by the intro of a famous 80s American pop song.

Comp:27  
Lo:64  
Hi:67  
VOL:85

Type:UE  
Sense:40  
ATTCK:95  
RESO:74  
Tone:2  
Oct:100  
BAL:52  
VOL:88

Range:1  
RESO:7  
Sense:10  
BAL:5

Depth:80  
Rate:42  
LoCut:180  
Mix:85

Time:417  
F.B:40  
Mix:17  
Tail:OFF

LEVEL  
16

## 043 : Raw Synth

This synth sound that uses Z-Syn has strong resonance.

Input:40  
Ratio:4:1  
REL:20  
Output:38

Gain:20  
FLTR:44  
VOL:64  
DryMx:46

FREQ:4  
Range:8  
Decay:40  
RESO:18  
Wave:SAW  
Tone:9  
BAL:63  
VOL:80

LEVEL  
41

## 044 : MOOGYFONIC

This analog synth sound combines Z-Syn, Ba Octave and CloneCho effects.

Input:32  
Ratio:4:1  
REL:20  
Output:46

FREQ:5  
Range:8  
Decay:72  
RESO:18  
Wave:SAW  
Tone:7  
BAL:80  
VOL:80

Oct:23  
Lo:5  
Hi:9  
Dry:80

Depth:2  
Rate:23  
Tone:73  
Mix:39

LEVEL  
27

# BANK L : CLEAN&DRV

## 045 : NYC Slap

This slap sound is good for jazz fusion.

**DYN COMP**  
 Sense:6  
 ATTCK:FAST  
 Tone:57  
 VOL:50

**AMPG SVT**  
 Bass:10.0  
 MID-F:120  
 MID:-1.0  
 Treble:8.5  
 Gain:30  
 Ultra:OFF  
 VOL:71

**BASS PEQ**  
 FREQ:100  
 Q:6.0  
 Gain:3.5  
 VOL:80

**TAPE ECHO**  
 Time:560  
 F.B:64  
 Mix:8  
 Tail:OFF

LEVEL 47

## 046 : Sweet SVT

This simple clean sound combines LMT-76 and AMPG SVT.

**LMT-76**  
 Input:31  
 Ratio:4:1  
 REL:20  
 Output:54

**AMPG SVT**  
 Bass:4.5  
 MID-F:220  
 MID:5.0  
 Treble:0.0  
 Gain:26  
 Ultra:OFF  
 VOL:71

LEVEL 25

## 047 : DirtyOGB15

This dirty drive sound combines FlipTop and CloneCho.

**BLACK OPT**  
 Comp:29  
 Lo:50  
 Hi:50  
 VOL:76

**FLIP TOP**  
 BRGHT:OFF  
 Treble:0.5  
 MID:3.5  
 Bass:4.5  
 Gain:30  
 Ultra:HI  
 VOL:70

**CLONE CHORUS**  
 Depth:1  
 Rate:29  
 Tone:86  
 Mix:40

LEVEL 30

## 048 : DISTORT ME

Combining DYN Comp and D.I Plus, this distortion sound has a nice attack.

**DYN COMP**  
 Sense:6  
 ATTCK:SLOW  
 Tone:50  
 VOL:50

**D.I PLUS**  
 Bass:66  
 MID:50  
 Treble:67  
 Color:ON  
 CHAN:DIST  
 Blend:52  
 Gain:46  
 VOL:85

**TAPE ECHO**  
 Time:560  
 F.B:64  
 Mix:12  
 Tail:OFF

LEVEL 32

# BANK M : DRIVE

## 049 : US Punk

This sound is inspired by West Coast American skate punk from the 2000s.

Exciter, AMPG SVT, SVT 8x10

LEVEL 98

Bass:0  
 Treble:53  
 VOL:65  
 ON/OFF:LATCH

Bass:-8.0  
 MID-F:1.0K  
 MID:6.5  
 Treble:5.5  
 Gain:44  
 Ultra:OFF  
 VOL:95

DYN20:29  
 DYN57:57  
 Bottom:29  
 BAL:100

## 050 : RockDrive

This drive sound is perfect for rock.

SQUEAK, BASS OD, BMAN100, SN 2x15

LEVEL 60

Gain:27  
 FLTR:43  
 VOL:50  
 DryMx:63

Gain:30  
 Tone:14  
 BAL:63  
 VOL:60

Bass:68  
 MID-F:160  
 MID:62  
 Treble:79  
 Gain:63  
 Deep:OFF  
 VOL:56

DYN20:55  
 DYN57:71  
 Bottom:65  
 BAL:100

## 051 : DirtyDist

This classic distortion sound is thick and rough.

BMAN100, VOODOO -B

LEVEL 78

Bass:50  
 MID-F:250  
 MID:55  
 Treble:63  
 Gain:55  
 Deep:OFF  
 VOL:55

Gain:41  
 Tone:46  
 Blend:100  
 VOL:80

## 052 : Race Car

This low-fi fuzz sound cuts the low-end.

MONOTONE, MT 1x15, VOODOO -B

LEVEL 47

Bass:0  
 MID:63  
 Treble:80  
 PRSNC:59  
 MODE:NORMAL  
 VOL:80

DYN20:50  
 DYN57:70  
 Bottom:27  
 BAL:100

Gain:39  
 Tone:71  
 Blend:92  
 VOL:80

# BANK N : FUZZ&OCT

## 053 : FuzzyLead

This fuzz sound, which includes BaFzSmile and BaMnPitch, is good for lead play.

Input:40 Ratio:4:1 REL:20 Output:51	Shift:12 Fine:0 Tone:10 BAL:10	FREQ:125 Lo:58 Hi:46 VOL:83	Gain:28 Tone:38 BAL:100 VOL:80	Time:560 F.B:30 Mix:14 Tail:OFF
--	---	--------------------------------------	---	--

## 054 : Fuzzynator

This flanger sound combines BassOctFZ with BaVinFLNG.

Sense:6 ATTCK:FAST Tone:50 VOL:13	Boost:70 Tone:23 Fuzz:61 Dry:64	Depth:47 Rate:7 RESO:8 LoCut:120
--	--	---

## 055 : Octavious

This octave sound uses Ba AnaOct and has a light filtering effect with Bass Cry.

Input:40 Ratio:4:1 REL:20 Output:38	OCT1:26 OCT2:8 MOD:29 Dry:83	Range:4 RESO:9 Sense:8 BAL:15
--	---------------------------------------	--

## 056 : Octaflange

This crossover sound combines Ba AnaOct and BaVinFLNG effects.

Input:26 Ratio:4:1 REL:20 Output:65	OCT1:11 OCT2:0 MOD:17 Dry:86	Depth:23 Rate:7 RESO:8 LoCut:400
--	---------------------------------------	---



# BANK 0 : OCTAVER

## 057 : Octaver

This is a typical octaver sound of the 80s and 90s.

Gain:40  
HMNCS:50  
LoType:SHELF  
LoFREQ:80  
Lo:0  
HIFREQ:1.5K  
Hi:6  
Vol:87

OCT1:28  
OCT2:0  
MOD:0  
Dry:75

Bass:23  
Treble:49  
VOL:69  
ON/OFF:LATCH

LEVEL  
52

## 058 : OctChorus

This cool bass sound combines octaver and chorus effects.

OCT1:65  
OCT2:8  
MOD:25  
Dry:86

Depth:75  
Rate:19  
LoCut:200  
Mix:76

LEVEL  
69

## 059 : OctVerb

This wide sounds combines octaver and reverb effects.

FREQ:1.5K  
LoCMP:24  
HiCMP:24  
VOL:75

Oct:36  
Lo:2  
Hi:8  
Dry:98

Bass:88  
L-MID:61  
H-MID:50  
Treble:45  
Blend:41  
Gain:39  
VOL:78  
Boost:LO

PreD:1  
Decay:20  
Mix:50  
Tail:OFF

LEVEL  
41

## 060 : ReggaeSub

This sound that emphasizes super low frequencies is good for reggae and dub styles.

Gain:50  
ENHNC:45  
SUB:0  
Lo:54  
Mid:65  
Hi:27  
BAL:100  
VOL:52

Gain:2  
Tone:54  
Blend:38  
VOL:72

Bass:0.0  
MID-F:220  
MID:0.0  
Treble:0.0  
Gain:30  
Ultra:OFF  
VOL:71

DYN20:50  
DYN57:50  
Bottom:50  
BAL:100

LEVEL  
87

# BANK P : FILTER&WAH

## 061 : Fretless

This sound simulates a fretless bass, combining Defret and BassStCho.

LEVEL: 43

Input:33 Ratio:4:1 REL:20 Output:62	Gain:44 Tone:6 HiCut:ON VOL:80	Sense:0 Color:8 Tone:37 VOL:80	Depth:28 Rate:27 LoCut:180 Mix:26	Time:560 F.B:30 Mix:16 Tail:OFF
--	---	---	--	--

## 062 : FilterThis

This funky filter sound, which uses EnvFilter, can be used for both rhythm and lead parts.

LEVEL: 33

Sense:2 ATTCK:FAST Tone:39 VOL:95	Gain:35 HMNCS:79 LoType:SHELF LoFREQ:97 Lo:9 HIFREQ:5.9K Hi:2 Vol:100	THRSH:5 ATTCK:80 Mode:UP VOL:84	Time:560 F.B:30 Mix:9 Tail:OFF
--	--	--	---

## 063 : WahsMyFuzz

This filtered phase sound combines Voodoo-B and Bass Cry.

LEVEL: 93

THRSH:-22 Ratio:4.0 Knee:SOFT VOL:80	Gain:41 Tone:46 Blend:45 VOL:80	Range:4 RESO:9 Sense:8 BAL:25
---	--	--

## 064 : FunnyFunk

This auto-wah sound is good for funky bass lines.

LEVEL: 45

Gain:42 HMNCS:70 LoType:PEQ LoFREQ:80 Lo:5 HIFREQ:1.5K Hi:5 Vol:87	Sense:2 RESO:3 Dry:0 VOL:73	THRSH:-23 Ratio:2.5 Knee:HARD VOL:95
---	--------------------------------------	---

# BANK Q : FUNKY EFX

## 065 : WawaFriend

This analog filter sound combines Pre1073 and EnvFilter effects.

LEVEL: 30

<b>LMT-76</b> Input:23 Ratio:4:1 REL:20 Output:62	<b>PRE 1073</b> Gain:45 Bass-F:55 Bass:15 MID-F:700 MID:20 TRBL-F:10K Treble:1 Vol:60	<b>ENV FILTER</b> THRSH:15 ATTK:0 Mode:UP VOL:94	<b>DELAY</b> Time:560 F.B:23 Mix:10 Tail:OFF
---	---	--	--

## 066 : Wah Solo

This auto-wah sound is perfect for emotional solos.

LEVEL: 80

<b>BASS A-WAH</b> Sense:1 RESO:6 Dry:50 VOL:80	<b>DYN COMP</b> Sense:7 ATTK: SLOW Tone:68 VOL:50	<b>BASS TS DRIVE</b> Gain:100 Tone:58 BAL:56 VOL:90	<b>AMPG SVT</b> Bass:0.0 MID-F:1.50 MID:4.5 Treble:2.5 Gain:30 Ultra:OFF VOL:28	<b>HALL</b> PreD:49 Decay:10 Mix:46 Tail:OFF
--	---	---	--	--

## 067 : FunkySolo

Hard compression is applied to this phase sound. Turn Bomber ON for the end of a solo.

LEVEL: 55

<b>MB COMP</b> Comp:80 LoTHR:60 HiTHR:40 VOL:61	<b>PHASER</b> Color:INV 8 Depth:84 Rate:15 RESO:7	<b>SPLUTTER</b> FREQ:125 Lo:38 Hi:44 VOL:80	<b>SPRING</b> PreD:40 Decay:10 Mix:8 Tail:OFF	<b>BOMBER</b> Decay:48 Tone:10 Mix:89 ON/OFF:TRGGR
---	---	---	---	--

## 068 : Jet Bomber

This intense explosive sound is like a jet.

LEVEL: 100

<b>BOMBER</b> Decay:80 Tone:8 Mix:26 ON/OFF:LATCH	<b>BASS VINTAGE FLANGER</b> Depth:60 Rate:19 RESO:8 LoCut:180	<b>PLATE</b> PreD:44 Decay:52 Mix:44 Tail:OFF
---	---	---

# BANK R : MODULATION

## 069 : CureLike

This is the clean sound of AMPG SVT combined with chorus and flanger effects.

LEVEL: 59

<b>AMPG SVT</b> Bass:-4.0 MID-F:160 MID:-4.0 Treble:-4.0 Gain:75 Ultra:BOTH VOL:50	<b>SVT 8x10</b> DYN20:50 DYN57:50 Bottom:50 BAL:100	<b>BASS STEREO CHORUS</b> Depth:75 Rate:27 LoCut:180 Mix:76	<b>BASS VINTAGE FLANGER</b> Depth:65 Rate:3 RESO:2 LoCut:OFF
---	---	---	--

## 070 : SlapDtune

Adding tone that has been slightly shifted in pitch and time give thickness to this slap sound.

LEVEL: 120

<b>BASS DETUNE</b> Cent:18 PreD:0 Tone:9 Mix:35	<b>BASS DETUNE</b> Cent:-18 PreD:0 Tone:8 Mix:35	<b>DUAL DELAY</b> TimeA:81 F.B A:1 TimeB:170 F.B B:1 DlyMx:0 BAL:6 Depth:MN-0 Speed:25	<b>HIGH EQ</b> Type:SHELF FREQ:10k Gain:4.0 VOL:90
---	--	--	--

## 071 : HotMonkey

This is a fuzzy flanger sound. This can be made even more aggressive by playing with a pick.

LEVEL: 48

<b>ENV FILTER</b> THRS:8 ATTK:66 Mode:UP VOL:45	<b>BASS OCT FUZZ</b> Boost:73 Tone:50 Fuzz:34 Dry:48	<b>BASS VINTAGE FLANGER</b> Depth:47 Rate:7 RESO:8 LoCut:60	<b>BRIGHT HALL</b> PreD:49 Decay:10 Tone:5 Mix:46
---	--	---	---

## 072 : StarshipTr

This is a tremolo sound that stands out.

LEVEL: 100

<b>FLIP TOP</b> BRGHT:OFF Treble:4.0 MID:0.0 Bass:12.0 Gain:30 Ultra:OFF VOL:70	<b>TE 4x10</b> DYN20:50 DYN57:50 Bottom:50 BAL:100	<b>TREMOLO</b> Wave:TRI Depth:90 Rate:50 VOL:62
--	--	---

# BANK S : TREMOLO

## 073 : WesternMOV

Combining Tremolo and AnalogDly, this sound is inspired by Western films.

LEVEL 12

<b>LMT-76</b> Input:40 Ratio:8:1 REL:20 Output:53	<b>PRE 1073</b> Gain:40 Bass-F:55 Bass:7 MID-F:700 MID:20 TRBL-F:10K Treble:7 Vol:80	<b>TREMOLO</b> Wave:TUBE Depth:73 Rate:67 VOL:87	<b>VOODOO-B</b> Gain:39 Tone:59 Blend:6 VOL:83	<b>ANALOG DELAY</b> Time:360 F.B:28 Mix:24 Tail:OFF
---	--	--	--	---

## 074 : SawFuzzing

This fuzz sound combines Tremolo and BaFzSmile.

LEVEL 72

<b>DYN COMP</b> Sense:6 ATTK:FAST Tone:46 VOL:57	<b>TREMOLO</b> Wave:TUBE Depth:50 Rate:56 VOL:69	<b>BA FZ SMILE</b> Gain:43 Tone:84 BAL:60 VOL:80	<b>EXCITER</b> Bass:59 Treble:50 VOL:49 ON/OFF:LATCH
--	--	--	--

## 075 : MagnumGuy

This thick tremolo sound combines Squeak, BaAnaOct and Tremolo effects.

LEVEL 42

<b>DYN COMP</b> Sense:6 ATTK:FAST Tone:50 VOL:48	<b>BASS ANALOGS OCTAVE</b> OCT1:65 OCT2:8 MOD:25 Dry:86	<b>SQUEAK</b> Gain:47 FLTR:66 VOL:79 DryMx:71	<b>TREMOLO</b> Wave:SQR Depth:92 Rate:73 VOL:62
--	---	---	---

## 076 : BlackHawk

This fuzz sound, which includes BaFzSmile and Tremolo, is good for playing long notes.

LEVEL 53

<b>LMT-76</b> Input:40 Ratio:12:1 REL:20 Output:18	<b>BA FZ SMILE</b> Gain:79 Tone:85 BAL:48 VOL:87	<b>TREMOLO</b> Wave:SQR Depth:91 Rate:75 VOL:89	<b>BASS PHASE</b> Color:1 Depth:100 Rate:55 RESO:56
--	--	---	---

# BANK T : PITCH&SYN

## 077 : MoStrings

This sound takes a fifth harmony and shifts it another octave.

LEVEL: 36

<b>LMT-76</b>	<b>PITCH SHIFT</b>	<b>BASS POLY SHIFT</b>	<b>DELAY</b>
Input:27 Ratio:4:1 REL:20 Output:60	Shift:7 Fine:0 Tone:3 BAL:27	Shift:12 Tone:68 Wet:60 Dry:80	Time:560 F.B:30 Mix:13 Tail:OFF

## 078 : Metheneish

Ba PDLmNp and VooDoo-B are combined with CloneCho in this synth brass style sound.

LEVEL: 43

<b>LMT-76</b>	<b>BASS PEDAL MONO PITCH</b>	<b>VOODOO-B</b>	<b>CLONE CHORUS</b>	<b>TAPE ECHO</b>
Input:26 Ratio:4:1 REL:49 Output:46	Bend:100 Color:+1 OCT Tone:5 Mode:UP	Gain:16 Tone:66 Blend:84 VOL:80	Depth:2 Rate:23 Tone:100 Mix:100	Time:560 F.B:24 Mix:21 Tail:OFF

## 079 : Minotaurio

This synth sound with harmony a third up combines BaStdSyn and HPS (Key C).

LEVEL: 26

<b>LMT-76</b>	<b>BASS STANDARD SYNTH</b>	<b>H.P.S.</b>	<b>SPLITTER</b>	<b>DELAY</b>
Input:40 Ratio:4:1 REL:20 Output:47	Mode:UP Sense:64 ATTCK:50 Range:64 RESO:57 Oct:87 BAL:40 VOL:80	Scale:3 Key:C Tone:7 Mix:80	FREQ:100 Lo:46 Hi:64 VOL:80	Time:560 F.B:30 Mix:19 Tail:OFF

## 080 : BubblSynth

This synth sound with strong resonance combines Z-Synth, Z Tron and Bass Cry.

LEVEL: 15

<b>LMT-76</b>	<b>Z-SYNTH</b>	<b>Z TRON</b>	<b>BASS CRY</b>
Input:40 Ratio:4:1 REL:20 Output:37	FREQ:9 Range:18 Decay:39 RESO:15 Tone:10 BAL:42 VOL:71	Sense:2 RESO:6 Dry:76 VOL:83	Range:4 RESO:8 Sense:8 BAL:19

# BANK U : DELAY 1

## 081 : HarmChords

This delay sound is perfect for playing chords.

DI-5 OPT COMP SUPER CHORUS ANALOG DELAY SPRING

LEVEL 39

Gain:66 Tone:OFF HiCut:OFF VOL:80	Drive:7 Lo:50 Hi:50 VOL:60	Depth:57 Rate:41 Tone:50 Mix:40	Time:502 F.B:35 Mix:43 Tail:OFF	PreD:26 Decay:23 Mix:13 Tail:OFF
--	-------------------------------------	--	--	---

## 082 : Tapping

This all-mighty tapping sound creates a feeling of chords.

DUAL COMP PRE 1073 PITCH SHIFT ANALOG DELAY HALL

LEVEL 71

FREQ:1.5K LoCMP:15 HiCMP:24 VOL:75	Gain:50 Bass-F:220 Bass:8 MID-F:1.6K MID:4 TRBL-F:10K Treble:18 Vol:52	Shift:12 Fine:0 Tone:5 BAL:8	Time:314 F.B:42 Mix:50 Tail:OFF	PreD:49 Decay:10 Mix:56 Tail:OFF
---	---	---------------------------------------	--	---

## 083 : Solo Bass

Combining delay and reverb, this clean sound is good for playing solos.

TAPE ECHO PLATE BLACK OPT

LEVEL 100

Time:560 F.B:64 Mix:56 Tail:OFF	PreD:9 Decay:52 Mix:44 Tail:OFF	Comp:50 Lo:50 Hi:50 VOL:76
--	--	-------------------------------------

## 084 : SpaceDelay

This spacey sounds combines auto-wah and delay.

SLOW ATTACK BASS A-WAH DELAY

LEVEL 100

Time:21 Curve:10 Tone:100 VOL:80	Sense:2 RESO:8 Dry:50 VOL:80	Time:560 F.B:30 Mix:70 Tail:OFF
---	---------------------------------------	--

# BANK V : DELAY 2

## 085 : Dramabass

This ambient sound combines TheVibe with Dual DLY.

LEVEL: 21

<b>LMT-76</b>	<b>THE VIBE</b>	<b>CORONA TRI</b>	<b>DUAL DELAY</b>
Input:40 Ratio:4:1 REL:20 Output:52	Speed:18 Depth:60 Mode:CHORS VOL:80	Depth:100 Speed:28 Tone:100 Mix:66	TimeA:500 F.B A:50 TimeB:375 F.B B:50 DlyMx:24 BAL:17 Depth:MN-0 Speed:25

## 086 : Lowismo

This delay sound that emphasizes notes an octave below is good for lead playing.

LEVEL: 42

<b>DYN COMP</b>	<b>BASS MONO PITCH</b>	<b>SPLUTTER</b>	<b>BASS STEREO CHORUS</b>	<b>TAPE ECHO</b>
Sense:6 ATTCK:SLOW Tone:50 VOL:50	Shift:-12 Fine:0 Tone:7 BAL:50	FREQ:125 Lo:32 Hi:38 VOL:80	Depth:75 Rate:27 LoCut:180 Mix:76	Time:560 F.B:64 Mix:56 Tail:OFF

## 087 : Copy Glass

A combination of BaPiShift and Dual DLY creates this glass-like sound.

LEVEL: 30

<b>LMT-76</b>	<b>BASS POLY SHIFT</b>	<b>DUAL DELAY</b>	<b>KICK FLANGER</b>
Input:40 Ratio:4:1 REL:20 Output:47	Shift:12 Tone:90 Wet:60 Dry:95	TimeA:500 F.B A:50 TimeB:375 F.B B:50 DlyMx:17 BAL:23 Depth:MN-0 Speed:25	PreD:4 Depth:61 Rate:41 ON/OFF:LATCH RESO:73 Mix:10 RST-F:50

## 088 : OUTAWORLD

The combination of PitchSHFT and ReverseDL create this mystical sound.

LEVEL: 34

<b>LMT-76</b>	<b>PITCH SHIFT</b>	<b>REVERSE DELAY</b>	<b>CORONA TRI</b>
Input:40 Ratio:4:1 REL:20 Output:53	Shift:7 Fine:0 Tone:10 BAL:60	Time:1000 F.B:20 BAL:50 Tail:OFF	Depth:100 Speed:13 Tone:100 Mix:45



# BANK W : SFX

## 089 : SwellUpper

This ambient tone that is good for playing long notes uses SlowATTCK and adds octaves above and below.

LEVEL 10

<b>SLOW ATTACK</b>	<b>BASS ANALOG OCTAVE</b>	<b>BASS PEDAL MONO PITCH</b>	<b>PRE 1073</b>	<b>TAPE ECHO</b>
Time:21 Curve:10 Tone:100 VOL:100	OCT1:65 OCT2:6 MOD:18 Dry:65	Bend:100 Color:DWN/OCT Tone:7 Mode:UP	Gain:50 Bass-F:55 Bass:0 MID-F:1.6K MID:0 TRBL-F:10K Treble:0 Vol:91	Time:560 F.B:64 Mix:18 Tail:OFF

## 090 : Lunarchoir

The combination of BaMnPitch, PitchSHFT and ReverseDL provides an effective organ sound.

LEVEL 11

<b>LMT-76</b>	<b>BASS MONO PITCH</b>	<b>PITCH SHIFT</b>	<b>CORONA TRI</b>	<b>REVERSE DELAY</b>
Input:40 Ratio:8:1 REL:20 Output:49	Shift:24 Fine:0 Tone:7 BAL:62	Shift:7 Fine:0 Tone:7 BAL:57	Depth:100 Speed:22 Tone:100 Mix:72	Time:1000 F.B:20 BAL:50 Tail:OFF

## 091 : PlayThe4

This mysterious delay sound uses a four-semitone pitch shift.

LEVEL 50

<b>DYN COMP</b>	<b>TE 400</b>	<b>BASS MONO PITCH</b>	<b>BASS CRY</b>	<b>DELAY</b>
Sense:6 ATTCK:FAST Tone:64 VOL:60	Style:FINGER Bass:0.5 MID:1.5 Treble:3.5 Gain:21 Shape:OFF VOL:71	Shift:4 Fine:4 Tone:4 BAL:29	Range:3 RESO:6 Sense:7 BAL:20	Time:520 F.B:20 Mix:20 Tail:OFF

## 092 : Got Swells

This sequencer sound is suitable for long notes.

LEVEL 56

<b>DYN COMP</b>	<b>SLOW ATTACK</b>	<b>BASS POLY SHIFT</b>	<b>SEQ FILTER</b>	<b>PLATE</b>
Sense:6 ATTCK:FAST Tone:80 VOL:93	Time:21 Curve:10 Tone:100 VOL:80	Shift:12 Tone:90 Wet:30 Dry:88	Step:8 PTRN:7 Speed:26 RESO:10	PreD:9 Decay:52 Mix:15 Tail:OFF

# BANK X : Aco.Basic

## 093 : PiezoUpRig

This is a basic clean sound for upright bass.

Input:40  
Ratio:8:1  
REL:20  
Output:59

Gain:25  
Bass-F:55  
Bass:17  
MID-F:700  
MID:22  
TRBL-F:10K  
Treble:12  
Vol:92

PreD:67  
Decay:50  
Mix:33  
Tail:OFF

LEVEL  
10

## 094 : Soloist

This clean sound combines LMT-76 and Pre1073.

Input:27  
Ratio:4:1  
REL:55  
Output:47

Gain:40  
Bass-F:220  
Bass:8  
MID-F:700  
MID:0  
TRBL-F:10K  
Treble:0  
Vol:60

Time:560  
F.B:44  
Mix:11  
Tail:OFF

LEVEL  
120

## 095 : SalsaBassQ

This is a clean sound for playing salsa on upright bass.

Input:40  
Ratio:8:1  
REL:20  
Output:53

Bass:64  
MID:29  
Treble:56  
Gain:39  
BRGHT:OFF  
Deep:ON  
VOL:81

DYN20:50  
DYN57:50  
Bottom:50  
BAL:100

PreD:49  
Decay:10  
Mix:46  
Tail:ON

LEVEL  
10

## 096 : Uborchestr

This lead tone for upright bass adds fifths.

Input:40  
Ratio:8:1  
REL:20  
Output:68

Shift:7  
Fine:0  
Tone:8  
BAL:17

Gain:30  
Bass-F:55  
Bass:13  
MID-F:700  
MID:19  
TRBL-F:10K  
Treble:24  
Vol:65

Depth:80  
Rate:62  
Tone:51  
Mix:42

PreD:43  
Decay:16  
Mix:30  
Tail:OFF

LEVEL  
20

# BANK Y : Aco.Bow&FX

## 097 : BowOrch

This lead tone for upright bass is good for playing with a bow.

LEVEL: 15

<b>LMT-76</b> Input:40 Ratio:8:1 REL:20 Output:65	<b>BASS MONO PITCH</b> Shift:-12 Fine:0 Tone:10 BAL:26	<b>PRE 1073</b> Gain:30 Bass-F:220 Bass:10 MID-F:700 MID:11 TRBL-F:16K Treble:15 Vol:60	<b>SPLITTER</b> FREQ:100 Lo:52 Hi:62 VOL:80	<b>HALL</b> PreD:37 Decay:10 Mix:17 Tail:OFF
---	--	---	---	--

## 098 : BowUpright

This basic clean sound for upright bass is good for playing with a bow.

LEVEL: 8

<b>LMT-76</b> Input:40 Ratio:8:1 REL:20 Output:66	<b>PRE 1073</b> Gain:25 Bass-F:55 Bass:11 MID-F:700 MID:13 TRBL-F:16K Treble:6 Vol:82	<b>BASS STEREO CHORUS</b> Depth:54 Rate:43 LoCut:60 Mix:30	<b>SPLITTER</b> FREQ:160 Lo:54 Hi:58 VOL:80	<b>BRIGHT HALL</b> PreD:15 Decay:10 Tone:5 Mix:46
---	---	--	---	---

## 099 : Marscoding

This modulation sound for upright bass uses PitchSHFT and Bass Cry effects.

LEVEL: 6

<b>LMT-76</b> Input:40 Ratio:8:1 REL:20 Output:70	<b>PITCH SHIFT</b> Shift:4 Fine:0 Tone:7 BAL:20	<b>BASS CRY</b> Range:4 RESO:9 Sense:4 BAL:48	<b>PRE 1073</b> Gain:30 Bass-F:220 Bass:14 MID-F:1.6K MID:16 TRBL-F:10K Treble:13 Vol:91	<b>THE VIBE</b> Speed:17 Depth:60 Mode:VIBRT VOL:75
---	---	---	--	---

## 100 : MYOWNCOMPS

This sequencer sound for upright bass uses PitchSHFT and SeqFLTR.

LEVEL: 7

<b>BLACK OPT</b> Comp:50 Lo:50 Hi:49 VOL:90	<b>PITCH SHIFT</b> Shift:7 Fine:0 Tone:9 BAL:15	<b>SEQ FILTER</b> Step:8 PTTRN:7 Speed:26 RESO:10	<b>AG 750</b> Bass:57 MID:56 Treble:56 Gain:68 BRIGHT:ON Deep:OFF VOL:84	<b>BASS STEREO CHORUS</b> Depth:76 Rate:27 LoCut:60 Mix:18
---	---	---	---	--



**ZOOM CORPORATION**

4-4-3 Kanda-surugadai, Chiyoda-ku, Tokyo 101-0062 Japan

[zoomcorp.com](http://zoomcorp.com)