

G11

Multi-Effects Processor
Preset Ver. 2.00

Patch Memory List

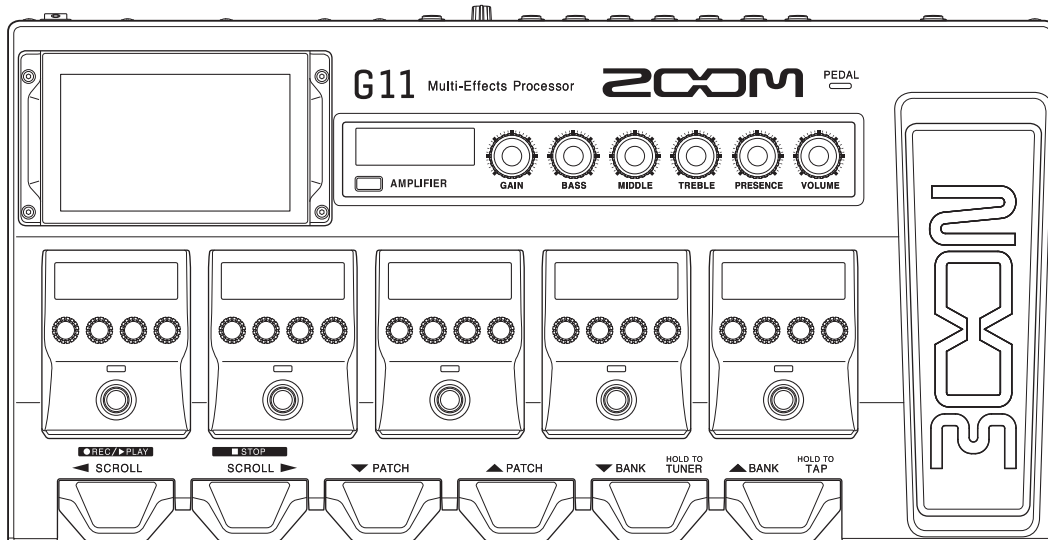

© 2021 ZOOM CORPORATION

Copying or reprinting this manual in part or in whole without permission is prohibited.

Product names, registered trademarks and company names in this document are the property of their respective companies. All trademarks and registered trademarks in this document are for identification purposes only and are not intended to infringe on the copyrights of their respective owners.

This document cannot be displayed properly on black-and-white displays.

About G11 PRESET PATCH MEMORY Version 2.00

In Version 2.00 of the Preset Patch Memories, we have added new patch memories designed for live performances using PA systems. These include 100 for guitar and 100 for bass, including acoustic bass. These patch memories use amps and preset IRs along with bass effects and other new additions in the G11 firmware update (Ver. 2.00). We have organized them into banks with clear concepts to make desired settings easy to find. These include re-creations of the sounds of legendary guitarists and bassists with orthodox amp sounds upfront, specific genres and unique effects.

We hope you enjoy the new sounds of the G11.

Old and new preset patch memories

Version 1.00

001-060	G11 PRESET PATCH MEMORY Version 1.00 (for PA System)
061-100	G11 PRESET PATCH MEMORY Version 1.00 (for Guitar Amp)
101-240	EMPTY



Version 2.00

001-060	G11 PRESET PATCH MEMORY Version 1.00 (for PA System)
061-100	G11 PRESET PATCH MEMORY Version 1.00 (for Guitar Amp)
101-240	EMPTY
241-340	NEW GUITAR PRESET PATCH MEMORY (for PA System)
341-440	NEW BASS PRESET PATCH MEMORY (for PA System)
441-500	EMPTY

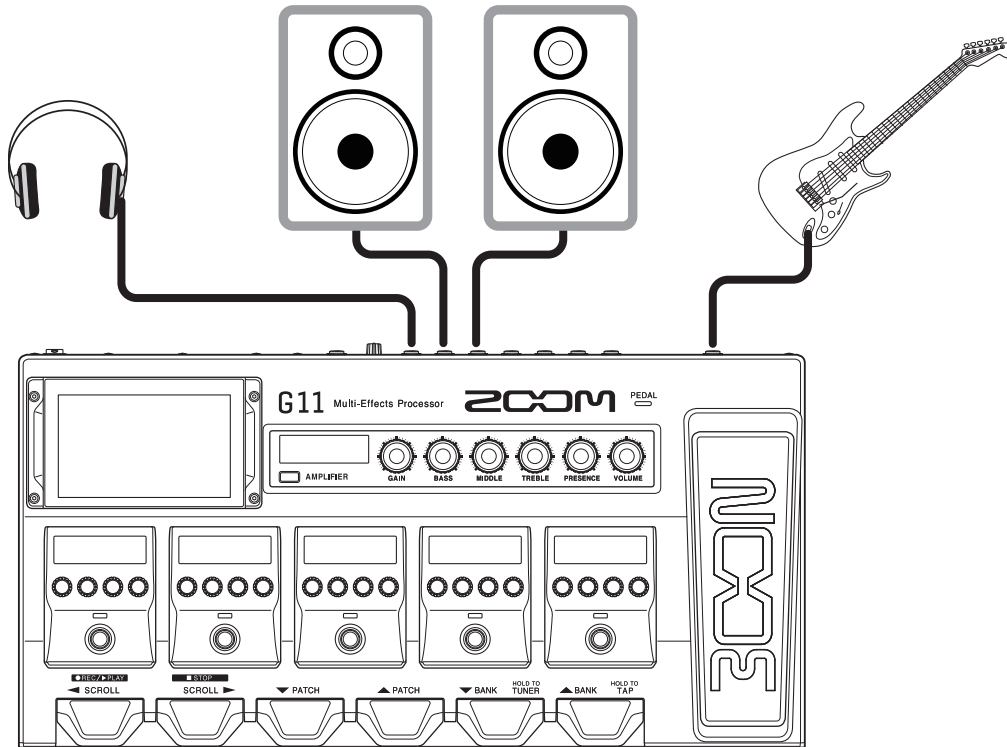

001-060 : G11 PRESET PATCH MEMORY Version 1.00 (for PA System)

Preset patch memories 001–060 optimize tones for use connected to PA systems.



To use this preset patch memory when connected to a guitar amp, turn off both the CABINET ( or  icon) and IR  .

Then adjust the EQ of the guitar amp as desired.

If the guitar input has a lot of noise, use noise reduction  and/or noise gate  .

BANK A : DIRECT 1

001 : KramRock

High gain sound that can be used for both lead and backing parts.

ZNR DETCT:GTRIN Depth:85 THRSH:30 Decay:0	BLACK WAH FREQ:50 Range:50 Dry:0 VOL:80	WAVE SHAPER Gain:8 Shape:12 Comp:61 VOL:97	KRAMPUS GAIN:47 BASS:47 MIDDLE:61 TREBLE:51 PRESENCE:63 VOLUME:56	IR LO:50 HI:50 BAL:100 VOL:-18.0	PARAMETORIC EQ FREQ:6.3K Q:1.2 Gain:4.5 VOL:84	CHURCH PreD:116 Decay:28 Mix:24 Tail:OFF	LEVEL 63
--	--	---	--	---	---	---	--------------------

002 : DBL Pollex

Doubling adds thickness to the drive sound.

ZNR DETCT:EFXIN Depth:100 THRSH:30 Decay:0	PEDAL VOL. VOL:100 Min:0 Max:100 Curve:A	POLLEX GAIN:50 BASS:39 MIDDLE:50 TREBLE:58 PRESENCE:77 VOLUME:49	IR LO:58 HI:50 BAL:100 VOL:-15.3	GEMINOS Tight:50 Mode:ST-2 Wet:75 Dry:75	ROOM PreD:36 Decay:10 Mix:60 Tail:OFF	LEVEL 85
---	---	---	---	---	--	--------------------

003 : CLNLoom

This beautiful clean sound is added an octave up.

PARAMETORIC EQ FREQ:100 Q:0.6 Gain:-2.5 VOL:80	REDLOOM GAIN:33 BASS:64 MIDDLE:44 TREBLE:49 PRESENCE:73 VOLUME:75	IR LO:77 HI:58 BAL:100 VOL:-17.0	POLY SHIFT Shift:12 Tone:70 Wet:29 Dry:70	STEREO CHORUS Depth:80 Rate:30 Tone:7 Mix:51	PEDAL VOL. VOL:100 Min:0 Max:100 Curve:B	PINGPONG DELAY Time:560 F.B:13 Mix:28 Tail:OFF	CHURCH PreD:96 Decay:49 Mix:36 Tail:ON	LEVEL 74
---	--	---	--	---	---	---	---	--------------------

004 : SoloVelv

Fat and smooth lead tones.

ZNR DETCT:EFXIN Depth:100 THRSH:42 Decay:0	BLACK WAH FREQ:40 Range:50 Dry:0 VOL:81	TS DRIVE Gain:0 Boost:OFF Tone:54 VOL:67	VELVET GAIN:55 BASS:61 MIDDLE:53 TREBLE:48 PRESENCE:62 VOLUME:54	IR LO:55 HI:55 BAL:100 VOL:-15.4	TAPE ECHO Time:414 F.B:48 Mix:46 Tail:ON	PLATE PreD:1 Decay:37 Mix:16 Tail:ON	LEVEL 76
---	--	---	---	---	---	---	--------------------

BANK B : DIRECT 2

005 : SwellVibe

Clean sound with vibrato on the sustain.

VOL:100 Min:0 Max:100 Curve:A	Depth:42 Speed:61 Rise:40 Vol:80	GAIN:30 BASS:38 MIDDLE:50 TREBLE:45 PRESENCE:67 VOLUME:40	LO:50 HI:50 BAL:100 VOL:-18.0	Input:22 Ratio:4:1 REL:39 Output:46	Time:360 F.B:27 Mix:49 Tail:OFF	PreD:7 Decay:49 Mix:38 Tail:OFF
--	---	--	--	--	--	--

006 : RazorPrnc

Extreme phase out sound.

VOL:100 Min:0 Max:100 Curve:A	DETECT:EFXIN Depth:100 THRSH:54 Decay:0	Mode:UP Sense:7 RESO:6 VOL:80	Gain:71 Edge:17 Lo:0 VOL:39	GAIN:27 BASS:62 MIDDLE:49 TREBLE:38 PRESENCE:57 VOLUME:63 INPUT:BRIGHT	LO:60 HI:61 BAL:100 VOL:-16.1	Shift:-12 Tone:90 Wet:36 Dry:80	PreD:4 Depth:62 Rate:3 RESO:3	PreD:1 Decay:10 Mix:60 Tail:OFF
--	--	--	--------------------------------------	--	--	--	--	--

007 : MS RoomMic

The room mic IR generates a realistic sound with a sense of air.

VOL:100 Min:0 Max:100 Curve:A	DETECT:GTRIN Depth:80 THRSH:44 Decay:0	GAIN:34 BASS:40 MIDDLE:66 TREBLE:56 PRESENCE:47 VOLUME:57 INPUT2:OFF	LO:48 HI:52 BAL:100 VOL:-18.0	LO:18 HI:43 BAL:4 VOL:-0.9	Input:31 Ratio:4:1 REL:20 Output:42	Time:330 F.B:15 Mix:24 Tail:OFF	PreD:44 Decay:10 Mix:60 Tail:OFF
--	---	--	--	-------------------------------------	--	--	---

008 : 7HVN-DST

The tight Djent sound good for 7 and 8 string guitars.

DETECT:0 GTRIN Boost:OFF Depth:100 THRSH:60 Decay:0	Gain:0 Q:16.0 Gain:6.0 VOL:72	FREQ:1.6K Q:16.0 Gain:6.0 VOL:80	GAIN:25 BASS:61 MIDDLE:33 TREBLE:64 PRESENCE:70 VOLUME:48	LO:52 HI:54 BAL:100 VOL:-16.9	FREQ:8.0K Q:0.6 Gain:1.0 VOL:80	PreD:4 Depth:61 Rate:41 ON/OFF:UnLATCH RESO:73 Mix:67 RST-F:50 LFO:RESET	Time:380 F.B:17 Mix:40 Tail:ON	VOL:100 Min:0 Max:100 Curve:A
---	--	---	--	--	--	---	---	--

BANK C : DIRECT 3

009 : SyncDLY

The sound that combines delays with different time settings.

LEVEL 50

PEDAL VOL. ZNR BLACK OPT UK30A IR IR MOD DELAY MOD DELAY HD HALL

VOL:100 DETCT: Comp:50 GAIN:25 LO:53 LO:61 Time: P. Time: J PreD:21
 Min:0 EFXIN Lo:50 BASS:55 HI:48 HI:55 F.B:38 F.B:36 Decay:34
 Max:100 Depth:100 Hi:50 MIDDLE:44 BAL:100 BAL:3 Mix:57 Mix:26 Mix:35
 Curve:A THRS:30 VOL:76 TREBLE:51 PRESENCE:51 VOLUME:80 CUT:78 Tail:OFF
 Decay:0 SPEED:0

010 : Red Hot

Clear and modern blues sound.

LEVEL 100

ZNR PEDAL VOL. REDLOOM IR GEMINOS HALL

DETCT:EFXIN VOL:100 GAIN:56 LO:35 Tight:50 PreD:49
 Depth:60 Min:0 BASS:52 HI:62 Mode:ST-2 Decay:13
 THRS:30 Max:100 MIDDLE:37 BAL:100 Wet:70 Mix:49
 Decay:0 Curve:B TREBLE:50 VOL:-16.0 Dry:70 Tail:ON
 PRESENCE:53 VOLUME:49

011 : MudBlues

This crunch sound is perfect for classic blues.

LEVEL 70

ZNR BLACK WAH EP STOMP MUDDY IR TREMOLO SOFT ECHO SPRING CHAMBER

DETCT:GTRIN FREQ:50 Gain:34 GAIN:73 LO:48 Wave:TUBE MOD:ON PreD:1 PreD:78
 Depth:75 Range:50 Bass:5 BASS:77 HI:60 Depth:70 Time:314 Decay:13 Decay:43
 THRS:20 Dry:0 Treble:-3 MIDDLE:69 BAL:100 Rate:55 F.B:33 Mix:26 Mix:30
 Decay:0 VOL:80 VOL:66 TREBLE:40 PRESENCE:52 VOLUME:45 Tail:OFF Tail:ON

012 : OctDown

This drive sound is added an octave down.

LEVEL 45

ZNR PEDAL VOL. BLACK OPT TAPE ECHO KRAMPUS IR POLY SHIFT PLATE

DETCT:EFXIN VOL:100 Comp:77 Time:560 GAIN:36 LO:39 Shift:-12 PreD:9
 Depth:100 Min:0 Lo:50 F.B:8 BASS:50 HI:66 Tone:58 Decay:45
 THRS:30 Max:100 Hi:76 Mix:40 MIDDLE:66 BAL:100 Wet:67 Mix:24
 Decay:0 Curve:A VOL:79 Tail:OFF PRESENCE:63 VOLUME:68 Tail:OFF

BANK D : DIRECT 4

013 : TransAC

Acoustic guitar sound a sense of transparency.

DETCT: 160:-1.0 EFXIN 400:0.0 Depth:50 THRSH:30 Decay:0	12k:2.5 VOL:80 CH SEL:LATCH	Top:80 Body:94 Tone:86 VOL:61	Input:40 Ratio:4:1 REL:20 Output:54	GAIN:32 BASS:48 MIDDLE:52 TREBLE:53 PRESENCE:52 VOLUME:83	VOL:100 Min:0 Max:100 Curve:A	Depth:40 Rate:25 Tone:6 Mix:13	Time:463 F.B:25 Mix:22 Tail:ON	PreD:9 Decay:33 Mix:29 Tail:OFF
---	-----------------------------------	--	--	--	--	---	---	--

014 : UK Combo

This crunch sound uses IR to achieve a realistic texture.

VOL:100 Min:0 Max:100 Curve:A	DETCT:EFXIN Depth:70 THRSH:30 Decay:0	Gain:15 Boost:OFF Tone:38 VOL:82	Time:600 F.B:10 Mix:11 Tail:OFF	GAIN:30 BASS:49 MIDDLE:50 TREBLE:38 PRESENCE:50 VOLUME:50 CUT:78 SPEED:0	LO:50 HI:50 BAL:100 VOL:-17.8	Input:31 Ratio:4:1 REL:20 Output:38	PreD:5 Decay:10 Mix:63 Tail:OFF
--	--	---	--	---	--	--	--

015 : PugetPsy

Drive sound that dramatically changes in distortion depending on the input.

DETCT: 100 EFXIN Range:50 Depth:100 THRSH:50 Decay:0	FREQ:50 Dry:0 VOL:80	Gain:50 Shape:100 Comp:0 VOL:27	Speed:19 Depth:28 Mode: CHORS VOL:70	GAIN:100 BASS:65 MIDDLE:42 TREBLE:60 PRESENCE:66 VOLUME:27 INPUT:BRILL	Time:548 F.B:45 Mix:44 Tail:ON	LO:44 HI:60 BAL:65 VOL:-14.3	100:0.5 200:0.0 400:0.5 800:-2.0 1.6k:0.5 3.2k:0.5 6.4k:5.5 VOL:80
--	----------------------------	--	--	--	---	---------------------------------------	---

016 : AMB PAD

Ambient sound to create a huge reverberation.

VOL:100 Min:0 Max:100 Curve:A	Comp:50 Lo:50 Hi:50 VOL:76	GAIN:21 BASS:37 MIDDLE:47 TREBLE:64 PRESENCE:76 VOLUME:100 INPUT:NORMAL SPEED:0	LO:51 HI:66 BAL:100 VOL:-16.8	Swell:9 Time:J F.B:71 Mix:64	Mode:STBL Decay:75 Mix:60 Tail:OFF	PreD:29 Decay:70 Mix:50 Tail:OFF	PreD:96 Decay:49 Mix:46 Tail:OFF
--	-------------------------------------	--	--	---------------------------------------	---	---	---

BANK E : DIRECT 5

017 : FunkyWah

This auto wah sound good for rhythm play.

LEVEL: 100

DETCT: EFYXIN	VOL:100	Mode:UP	Boost:15	Color:8	STG	GAIN:26	LO:65	Time: J	PreD:75
Depth:100	Min:0	Sense:9	Color:2	Depth:69		BASS:51	HI:57	F.B:30	Decay:30
THRSH:30	Curve:A	RESO:8	Tone:36	Rate:12		TREBLE:59	BAL:100	Mix:30	Mix:25
Decay:0		VOL:80	VOL:45	RESO:50		PRESENCE:40	VOL:-17.1	Tail:ON	Tail:ON
						VOLUME:68			
						INPUT:30			

018 : CntryCLN

Compression is applied to this clean sound that suits playing country music well.

LEVEL: 73

DETCT:GTRIN	SUSTN:100	GAIN:32	LO:49	Input:40	VOL:100	Time:94	PreD:1
Depth:75	Lo:60	BASS:37	HI:60	Ratio:4:1	Min:0	F.B:17	Decay:20
THRSH:70	Hi:68	MIDDLE:63	BAL:100	REL:20	Max:100	Mix:38	Mix:27
Decay:0	VOL:28	TREBLE:58	VOL:-17.5	Output:53	Curve:A	Tail:OFF	Tail:OFF
		PRESENCE:71					
		VOLUME:59					
		BRIGHT:OFF					
		SPEED:0					

019 : Unchain

This high gain sound is perfect for hard rock with flangers.

LEVEL: 47

DETCT:GTRIN	Gain:40	PreD:23	GAIN:77	LO:42	Time:371	VOL:100
Depth:100	Bass:50	Depth:42	BASS:78	HI:64	F.B:41	Min:0
THRSH:70	Treble:61	Rate:13	MIDDLE:47	BAL:100	Mix:47	Max:100
Decay:35	VOL:43	RESO:1	TREBLE:63	VOL:-16.0	Tail:OFF	Curve:A
			PRESENCE:63			
			VOLUME:70			

020 : OctUpRazor

This octave fuzz sound is perfect for classic rock.

LEVEL: 82

Gain:29	Boost:26	FREQ:17	GAIN:65	LO:77	Speed:17	DETCT:GTRIN	PreD:44
Edge:56	Color:2	Range:89	BASS:67	HI:56	Depth:60	Depth:53	Decay:54
Lo:68	Tone:50	Dry:10	MIDDLE:52	BAL:100	Mode:CHORS	THRSH:32	Mix:22
VOL:57	VOL:55	VOL:100	TREBLE:57	VOL:-18.4	VOL:71	Decay:45	Tail:ON
			PRESENCE:56				
			VOLUME:64				

BANK F : DIRECT 6

021 : KramDrive

High gain lead tone with a rich mid range.

LEVEL: 66

ZNR DETCT:EFXIN Gain:0 Depth:100 Boost:OFF THRSH:42 Tone:65 Decay:0 VOL:74	KRAMPUS GAIN:29 BASS:27 MIDDLE:81 TREBLE:43 PRESENCE:56 VOLUME:64	IR LO:38 HI:62 BAL:100 VOL:-16.7	GUITAR GEQ 160:-1.0 400:2.0 800:3.5 3.2k:0.5 6.4k:-1.0 12k:-2.0 VOL:83 CH SEL:LATCH	PEDAL VOL. VOL:100 Min:0 Max:100 Curve:B	PINGPONG DELAY Time:500 F.B:30 Mix:44 Tail:ON	HALL PreD:1 Decay:15 Mix:23 Tail:ON
---	--	--	--	---	--	--

022 : Sparky

This clean sound good for funky playing.

LEVEL: 70

PEDAL VOL. VOL:100 Min:0 Max:100 Curve:A	ZNR DETCT:EFXIN Depth:100 THRSH:30 Decay:0	BLACK OPT Comp:50 Lo:50 Hi:50 VOL:76	REDLOOM GAIN:41 BASS:55 MIDDLE:45 TREBLE:58 PRESENCE:63 VOLUME:53	IR LO:42 HI:54 BAL:100 VOL:-15.7	DELAY Time:560 F.B:17 Mix:13 Tail:OFF	HD HALL PreD:29 Decay:21 Mix:29 Tail:OFF
---	---	---	--	--	--	---

023 : RectoPan

Metal sound with left and right panning.

LEVEL: 100

ZNR DETCT:EFXIN Depth:100 THRSH:30 Decay:0	PARAMETORIC EQ FREQ:100 Q:0.6 Gain:-2.5 VOL:80	TS DRIVE Gain:0 Boost:OFF Tone:57 VOL:100	RCT ORG GAIN:70 BASS:52 MIDDLE:63 TREBLE:58 PRESENCE:56 VOLUME:70 MODE:VNTG	IR LO:56 HI:64 BAL:100 VOL:-17.3	GEMINOS Tight:49 Mode:ST-1 Wet:80 Dry:85	HALL PreD:1 Decay:10 Mix:36 Tail:ON	PEDAL VOL. VOL:100 Min:0 Max:100 Curve:A
---	---	--	---	--	---	--	---

024 : FD Clean

Simple clean sound.

LEVEL: 100

ZNR DETCT:EFXIN Depth:60 THRSH:30 Decay:0	PEDAL VOL. VOL:100 Min:0 Max:100 Curve:A	OPT COMP Drive:5 Lo:50 Hi:50 VOL:60	FD TWINR GAIN:30 BASS:42 MIDDLE:44 TREBLE:39 PRESENCE:50 VOLUME:90 BRIGHT:OFF SPEED:0	IR LO:50 HI:50 BAL:100 VOL:-14.5	LMT-76 Input:29 Ratio:4:1 REL:20 Output:44	ROOM PreD:5 Decay:10 Mix:60 Tail:OFF
--	---	--	--	--	---	---

BANK G : DIRECT 7

025 : MudFuzz

This roaring fuzz sound is perfect for alternative rock.

DETCT:GTRIN FREQ:50 Bass:-1 SUSTN:24 GAIN:30 LO:40 MOD:ON PreD:1 PreD:86
 Depth:75 Range:50 Treble:-5 Tone:62 BASS:34 HI:58 Time:314 Decay:13 Decay:40
 THRSH:20 Dry:0 VOL:65 BAL:31 VOL:92 MIDDLE:69 BAL:100 F.B:33 Mix:26 Mix:24
 Decay:0 VOL:80 PRESENCE:62 VOLUME:50 Tail:OFF Tail:ON

026 : VintageRK

This vintage rock sound uses tremolo.

DETCT:EFXIN VOL:100 GAIN:48 LO:50 Wave:TUBE Depth:33 PreD:27
 Depth:60 Min:0 BASS:19 HI:62 Depth:46 Rate:19 Decay:19
 THRSH:30 Max:100 MIDDLE:38 BAL:100 Rate:46 Tone:3 Mix:29
 Decay:0 Curve:A PRESENCE:50 VOLUME:35 Tail:OFF

027 : FuzzBend

Fuzz sound with pedal control of the pitch.

DETCT:EFXIN Bend:0 Comp:50 Boost:65 GAIN:50 LO:45 Time:J PreD:29
 Depth:100 Color:+1 OCT Lo:50 Color:2 HI:50 HI:66 F.B:53 Decay:21
 THRSH:52 Tone:10 Mode:UP VOL:76 VOL:68 MIDDLE:50 BAL:100 Mix:49 Mix:29
 Decay:0 Mode:UP VOL:76 VOL:68 PRESENCE:40 VOLUME:50 Tail:OFF Tail:OFF

028 : 45 Clean

This clear and clean sound takes advantage of the amplifier character.

DETCT:EFXIN VOL:100 Gain:20 GAIN:29 LO:50 Depth:100 Time:J PreD:52
 Depth:100 Min:0 Bass:48 BASS:50 HI:58 Rate:26 F.B:30 Decay:40
 THRSH:30 Max:100 Treble:50 MIDDLE:70 BAL:100 Tone:49 Mix:30 Mix:60 Mix:33
 Decay:0 Curve:A VOL:50 PRESENCE:42 VOLUME:78 INPUT2:OFF Tail:ON Tail:ON Tail:ON

BANK H : DIRECT 8

029 : Knockout

This high gain sound is perfect for metal rhythm guitar.

ZNR DETCT:EFXIN Depth:100 THRSH:50 Decay:0	COMP Sense:6 ATTCK:FAST Tone:10 VOL:62	RCT ORG GAIN:75 BASS:52 MIDDLE:62 TREBLE:77 PRESENCE:68 VOLUME:65 MODE:VNTG	IR LO:50 HI:60 BAL:100 VOL:-16.9	GUITAR GEQ 7 100:4.0 200:0.0 400:-0.5 800:-2.5 1.6k:-0.5 3.2k:1.0 6.4k:1.0 VOL:80	PEDAL VOL. VOL:100 Min:0 Max:100 Curve:A	LEVEL 83
---	---	---	---	--	---	--------------------

030 : HW Dotted

The dotted eight note delay sound. Control the delay time with the TAP tempo.

PEDAL VOL. VOL:100 Min:0 Max:100 Curve:A	BLACK OPT Comp:50 Lo:50 Hi:50 VOL:76	HW100 GAIN:30 BASS:31 MIDDLE:78 TREBLE:64 PRESENCE:60 VOLUME:60 INPUT:BRILL	IR LO:48 HI:55 BAL:100 VOL:-16.3	MOD DELAY Time:J. F.B:50 Mix:60 Tail:OFF	HD HALL PreD:18 Decay:27 Mix:47 Tail:OFF	LEVEL 68
---	---	---	---	---	---	--------------------

031 : PLX DRV

Straight drive sound.

ZNR DETCT:GTRIN Depth:75 THRSH:20 Decay:0	PEDAL VOL. VOL:100 Min:0 Max:100 Curve:A	RC BOOST Gain:19 Bass:47 VOL:56	POLLEX GAIN:21 BASS:39 MIDDLE:56 TREBLE:33 PRESENCE:34 VOLUME:58	IR LO:63 HI:57 BAL:100 VOL:-17.3	TAPE ECHO-3 Gain:37 Lo:55 VOL:79 TIME:367 F.B:27 MIX:15 REC LV:50	AMBIENCE PreD:29 Decay:70 Mix:43 Tail:OFF	ROOM PreD:18 Decay:19 Mix:51 Tail:OFF	LEVEL 78
--	---	---	---	---	---	--	--	--------------------

032 : TheWater

Sequence filter sound with modulation.

ZNR DETCT:EFXIN Depth:60 THRSH:30 Decay:0	PEDAL VOL. VOL:100 Min:0 Max:100 Curve:A	BLACK OPT Comp:22 Lo:43 Hi:80 VOL:65	SEQ FILTER Step:8 PTRN:5 Speed:27 RESO:7	BG MK3 GAIN:160 BASS:52 MIDDLE:62 TREBLE:25 PRESENCE:35 VOLUME:37 GAIN:75	WARP PHASER Mode:BACK Speed:13 RESO:3 VOL:80	STEREO CHDRUS Depth:80 Rate:30 Tone:10 Mix:60	HD HALL PreD:81 Decay:57 Mix:50 Tail:OFF	LEVEL 80
--	---	---	---	---	---	--	---	--------------------

BANK I : DIRECT 9

033 : 60's

60's style sound with spring reverb.

Level: 88

ZNR	PEDAL VOL.	BLACK OPT	FD DLXR	IR	IR	SLAP BACK-D	SPRING
DETCT:GTRIN Depth:73 THRSH:30 Decay:0	VOL:100 Min:0 Max:100 Curve:A	Comp:50 Lo:50 Hi:50 VOL:76	GAIN:56 BASS:33 MIDDLE:46 TREBLE:61 PRESENCE:68 VOLUME:100 INPUT:NORMAL SPEED:0	LO:52 HI:67 BAL:100 VOL:-17.6	LO:50 HI:50 BAL:5 VOL:-0.7	Time:99 F.B:29 Mix:40 SubDv:J	PreD:35 Decay:20 Tail:OFF

034 : DirtyOCT

This dirty octave sound is perfect for hip hop.

Level: 120

ZNR	PEDAL VOL.	OCTAVE	COMP	RC BOOST	RCT ORG	IR	PLATE
DETCT:GTRIN Depth:75 THRSH:30 Decay:0	VOL:100 Min:0 Max:100 Curve:A	OCT1:80 OCT2:15 Dry:100	Sense:4 ATTCK:SLOW Tone:8 VOL:33	Gain:56 Bass:42 Treble:52 VOL:36	GAIN:73 BASS:32 MIDDLE:62 TREBLE:58 PRESENCE:78 VOLUME:32 MODE:VNTG	LO:42 HI:56 BAL:100 VOL:-15.8	PreD:9 Decay:24 Mix:23 Tail:OFF

035 : KramHot

Warm and aggressive high gain sound.

Level: 64

ZNR	PEDAL VOL.	TS DRIVE	KRAMPUS	IR	EG FILTER	DELAY	HD HALL
DETCT:EFXIN Depth:100 THRSH:30 Decay:0	VOL:100 Min:0 Max:100 Curve:A	Gain:37 Boost:OFF Tone:50 VOL:77	GAIN:50 BASS:42 MIDDLE:67 TREBLE:53 PRESENCE:74 VOLUME:58	LO:45 HI:62 BAL:100 VOL:-18.6	FREQ1:90 FREQ2:0 RESO:0 Type:LPF2 Speed:15 BAL:100 VOL:72 CNTRL:UnLATCH	Time:J F.B:17 Mix:50 Tail:ON	PreD:29 Decay:21 Mix:23 Tail:OFF

036 : MoonSnow

This mystical sound uses reverse delay.

Level: 110

ZNR	POLY SHIFT	FD TWINR	REVERSE DELAY	IR	PEDAL REVERB
DETCT:EFXIN Depth:60 THRSH:30 Decay:0	Shift:12 Tone:48 Wet:73 Dry:70	GAIN:61 BASS:74 MIDDLE:50 TREBLE:36 PRESENCE:34 VOLUME:69 BRIGHT:OFF SPEED:0	Time:1000 F.B:14 BAL:31 Tail:ON	LO:81 HI:55 BAL:100 VOL:-15.0	InLvl:100 PreD:49 Decay:24 Mix:90

BANK J : DIRECT 10

037 : CryPhase

The clean sound with pedal control of the phaser.

LEVEL 113

ZNR DETCT:EPXIN Depth:100 THRSH:30 Decay:0	PEDAL PHASER Rate:17 Depth:89 RESO:50 Color:8 STG	FD TWINR GAIN:35 BASS:45 MIDDLE:48 TREBLE:33 PRESENCE:39 VOLUME:99 BRIGHT:OFF SPEED:0	IR LO:50 HI:54 BAL:100 VOL:-13.5	ANALOG DELAY Time:360 F.B:28 Mix:34 Tail:OFF	SPRING PreD:1 Decay:14 Mix:13 Tail:OFF
---	--	--	---	---	---

038 : VelvLead

This wide lead tone uses a stereo chorus.

LEVEL 80

ZNR DETCT:GTRIN Depth:100 THRSH:30 Decay:50	PEDAL VOL VOL:100 Min:0 Max:100 Curve:A	TS DRIVE Gain:12 Boost:OFF Tone:47 VOL:100	VELVET GAIN:26 BASS:52 MIDDLE:58 TREBLE:74 PRESENCE:36 VOLUME:50	IR LO:50 HI:56 BAL:100 VOL:-17.6	STEREO CHORUS Depth:62 Rate:25 Tone:7 Mix:20	PINGPONG DELAY Time:520 F.B:30 Mix:35 Tail:ON
--	--	---	---	---	---	--

039 : 30 Crunch

This bright crunch sound takes advantage of the amplifier character.

LEVEL 75

ZNR DETCT:EPXIN Depth:100 THRSH:59 Decay:0	BLACK OPT Comp:50 Lo:50 Hi:50 VOL:76	TS+BOOST Gain:67 Tone:50 VOL:75 Comp:1 BOOST:60 BASS:40 TREBLE:50 CONNECT: BOOST:OD	MATCH30 GAIN:46 BASS:56 MIDDLE:43 TREBLE:41 PRESENCE:56 VOLUME:95 GAIN2:OFF CUT:0	IR LO:50 HI:50 BAL:100 VOL:-15.5	DUAL DELAY TimeA: J F.B A:18 TimeB: J F.B B:17 DyMx:23 BAL:15 DEPTH:ST-26 SPEED:19	HD HALL PreD:78 Decay:41 Mix:29 Tail:ON	PEDAL VOL VOL:100 Min:0 Max:100 Curve:A
---	---	---	--	---	---	--	--

040 : SciFiSyn

Synth like sci-fi sound inspired by the universe.

LEVEL 49

PEDAL VOL VOL:100 Min:0 Max:100 Curve:A	HDT SPICE Bend:11 Buzz:57 +1oct:36 VOL:80	RING MODULATOR FREQ:40 Tone:2 BAL:50 VOL:88	UK30A GAIN:33 BASS:63 MIDDLE:30 TREBLE:34 PRESENCE:33 VOLUME:64 CUT:78 SPEED:0	CORONA TRI Depth:100 Speed:25 Tone:100 Mix:86	SLOW ATTACK DELAY Swell:31 Time:490 F.B:75 Mix:64	IR LO:58 HI:50 BAL:100 VOL:-15.0	CHURCH PreD:43 Decay:42 Mix:41 Tail:OFF
--	--	--	---	--	--	---	--

BANK K : DIRECT 11

041 : Jazz CLN

This clean sound is perfect for jazz.

Comp:13 GAIN:24 LO:48 100:0.0 Input:40 VOL:100 Time:283 Depth:40 PreD:29
 Lo:50 BASS:80 HI:50 200:0.5 Ratio:4:1 Min:0 F.B:37 Rate:25 Decay:33
 Hi:50 MIDDLE:69 TREBLE:53 400:2.5 REL:20 Max:100 Mix:19 Tone:7 Mix:22
 VOL:25 PRESENCE:46 VOLUME:65 800:2.5 Output:70 Curve:A Tail:ON Mix:24 Tail:OFF
 1.6k:1.5
 3.2k:0.0
 6.4k:2.5
 VOL:80

042 : BOMBER!!!

Ambient sound to amplify the sound of an explosion.

Decay:50 GAIN:33 LO:38 Pitch:0.05 INTVL:OCT PreD:29 VOL:100
 Tone:4 BASS:46 HI:56 Time:90 Time:J Decay:100 Min:0
 Mix:43 MIDDLE:49 BAL:100 F.B:80 F.B:62 Mix:100 Max:100
 ON/OFF:TRGGR TREBLE:61 VOL:-17.5 Mix:80 Mix:76 Tail:OFF Curve:A
 PRESENCE:52 VOLUME:73 GAIN2:OFF CUT:0

043 : Rifforama

The thick and high gain sound is perfect for dynamic riffs.

DETCT:GTRIN VOL:100 Gain:62 GAIN:66 LO:40 PreD:5
 Depth:100 Min:0 Bass:71 BASS:79 HI:68 Decay:10
 THRSH:63 Max:100 Treble:59 MIDDLE:56 BAL:100 Mix:60
 Decay:60 Curve:A VOL:39 TREBLE:57 PRESENCE:73 Tail:OFF
 VOLUME:66

044 : WorshipAMB

This ambient sound is perfect for gospel music.

DETCT:EFXIN VOL:100 Shift:12 Depth:94 GAIN:28 LO:56 Time:J Time:J PreD:10
 Depth:100 Min:0 Fine:0 Rate:37 BASS:61 HI:63 F.B:30 F.B:30 Decay:50
 THRSH:30 Max:100 Tone:3 Tone:50 MIDDLE:67 BAL:100 Mix:60 Mix:30 Mix:40
 Decay:0 Curve:A BAL:13 Mix:50 TREBLE:59 VOL:-17.2 Tail:ON Tail:ON Tail:ON
 PRESENCE:80 VOLUME:59 INPUT:22

BANK L : POPS

045 : Pops CLN

This clean sound good for pop.

DETECT:EFXIN	VOL:100	Gain:10	Depth:98	GAIN:28	LO:50	Time: J	Time: J	PreD:9
Depth:100	Min:0	Boost:OFF	Rate:30	BASS:59	HI:63	F.B:30	F.B:30	Decay:30
THRSH:30	Max:100	Tone:40	Tone:50	MIDDLE:51	BAL:100	Mix:60	Mix:30	Mix:25
Decay:0	Curve:A	VOL:50	Mix:100	TREBLE:56	VOL:-18.1	Tail:ON	Tail:ON	Tail:ON
				PRESENCE:75				
				VOLUME:65				

046 : Pops DRV

This drive sound good for pop.

DETECT:EFXIN	FREQ:50	Gain:40	Depth:98	GAIN:60	LO:50	Time: J	PreD:9
Depth:100	Range:50	Boost:OFF	Rate:30	BASS:38	HI:68	F.B:30	Decay:30
THRSH:30	Dry:0	Tone:65	Tone:50	MIDDLE:35	BAL:100	Mix:25	Mix:25
Decay:0	VOL:80	VOL:50	Mix:100	TREBLE:56	VOL:-17.0	Tail:ON	Tail:ON
				PRESENCE:69			
				VOLUME:35			

047 : Pops LEAD

This lead tone good for pop.

DETECT:EFXIN	FREQ:50	Gain:25	GAIN:72	LO:49	Time: J	Time: J	PreD:36
Depth:100	Range:50	Tone:55	BASS:50	HI:59	F.B:26	F.B:30	Decay:30
THRSH:30	Dry:0	Focus:72	MIDDLE:45	BAL:100	Mix:34	Mix:33	Mix:29
Decay:0	VOL:80	VOL:58	TREBLE:59	VOL:-17.0	Tail:OFF	Tail:OFF	Tail:ON
			PRESENCE:76				
			VOLUME:37				

048 : Pops PAD

This pad sound good for pop.

DETECT:EFXIN	VOL:100	Sense:6	GAIN:35	LO:45	Depth:83	Time: J	PreD:33	Mode:STBL
Depth:100	Min:0	ATTCK:SLOW	BASS:46	HI:60	Rate:24	F.B:30	Decay:55	Decay:75
THRSH:30	Max:100	Tone:6	MIDDLE:47	BAL:100	Tone:50	Mix:53	Mix:50	Mix:60
Decay:0	Curve:A	VOL:49	TREBLE:48	VOL:-17.2	Mix:100	Tail:ON	Tail:ON	Tail:ON
			PRESENCE:73					
			VOLUME:55					

BANK M : FUSION

049 : Fusion CLN

This clean sound good for fusion.

LEVEL 79

Comp:0 Lo:50 Hi:50 VOL:28	GAIN:32 BASS:73 MIDDLE:65 TREBLE:53 PRESENCE:69 VOLUME:47 BRIGHT:OFF SPEED:0	LO:48 HI:56 BAL:100 VOL:-17.5	Input:35 Ratio:4:1 400:4.5 800:5.0 3.2k:3.0 6.4k:2.0 12k:0.0 VOL:96 CH SEL:LATCH	160:5.5 400:4.5 800:5.0 3.2k:3.0 6.4k:2.0 12k:0.0 VOL:96 CH SEL:LATCH	VOL:100 Min:0 Max:100 Curve:A	Depth:40 Rate:25 Tone:6 Mix:16	Time:463 F.B:25 Mix:22 Tail:ON	PreD:9 Decay:33 Mix:22 Tail:OFF
------------------------------------	---	--	--	--	--	---	---	--

050 : Fusion DRV

This drive sound good for fusion.

LEVEL 100

DETCT:EFXIN Depth:60 THRSH:30 Decay:0	Comp:0 Lo:52 Hi:50 VOL:31	GAIN:100 BASS:57 MIDDLE:45 TREBLE:58 PRESENCE:63 VOLUME:38 GAIN2:OFF CUT:0	LO:40 HI:64 BAL:100 VOL:-19.6	VOL:100 Min:0 Max:100 Curve:A	Depth:40 Rate:25 Tone:6 Mix:13	Time:463 F.B:25 Mix:22 Tail:OFF	PreD:9 Decay:33 Mix:22 Tail:OFF
--	------------------------------------	---	--	--	---	--	--

051 : FusionLEAD

This lead tone good for fusion.

LEVEL 100

DETCT:EFXIN Depth:80 THRSH:30 Decay:0	Gain:32 Bass:50 Treble:51 VOL:51	GAIN:50 BASS:59 MIDDLE:59 TREBLE:35 PRESENCE:36 VOLUME:47	LO:59 HI:51 BAL:100 VOL:-17.3	VOL:100 Min:0 Max:100 Curve:A	Shift:-12 Tone:90 Wet:37 Dry:80	Time:J F.B:17 Mix:30 Tail:OFF	PreD:1 Decay:52 Mix:17 Tail:OFF
--	---	--	--	--	--	--	--

052 : Fusion AMB

This ambient sound good for fusion.

LEVEL 100

VOL:100 Min:0 Max:100 Curve:A	GAIN:34 BASS:65 MIDDLE:76 TREBLE:65 PRESENCE:61 VOLUME:84 GAIN2:OFF CUT:0	LO:61 HI:64 BAL:100 VOL:-17.9	Pitch:0.05 Time:468 F.B:46 Mix:44	INTVL:OCT Time:J F.B:43 Mix:41	PreD:29 Decay:82 Mix:63 Tail:OFF	PreD:26 Decay:72 Mix:42 Tail:OFF
--	--	--	--	---	---	---

BANK N : BLUES

053 : Blues CLN

This clean sound good for blues.

LEVEL 120

DETECT:EFXIN	VOL:100	Color:0	GAIN:32	LO:67	Time: J	Time: J	PreD:52
Depth:100	Min:0	Lo:100	BASS:58	HI:60	F.B:36	F.B:30	Decay:26
THRSH:30	Max:100	Hi:100	MIDDLE:51	BAL:100	Mix:65	Mix:25	Mix:25
Decay:0	Curve:A	Mix:26	TREBLE:58	VOL:-16.8	Tail:ON	Tail:ON	Tail:ON
PRESENCE:75 VOLUME:80 INPUT:NORMAL SPEED:12							

054 : Blues DRV

This drive sound good for blues.

LEVEL 110

DETECT:EFXIN	FREQ:50	Gain:20	PreD:1	GAIN:78	LO:53	Time: J	Size:26	PreD:64
Depth:100	Range:50	Tone:50	Decay:15	BASS:63	HI:57	F.B:36	REF:5	Decay:26
THRSH:30	Dry:0	Focus:67	Mix:9	MIDDLE:51	BAL:100	Mix:65	Mix:53	Mix:28
Decay:0	VOL:80	VOL:50	Tail:OFF	TREBLE:63	VOL:-16.2	Tail:ON	Tail:OFF	Tail:ON
PRESENCE:84 VOLUME:69 INPUT:NORMAL SPEED:0								

055 : Blues LEAD

This lead tone good for blues.

LEVEL 120

DETECT:EFXIN	FREQ:50	Gain:20	GAIN:69	LO:62	MOD:ON	Size:18	PreD:52
Depth:100	Range:50	Boost:OFF	BASS:59	HI:61	Time:384	REF:5	Decay:26
THRSH:30	Dry:0	Tone:62	MIDDLE:40	BAL:100	F.B:37	Mix:55	Mix:25
Decay:0	VOL:80	VOL:90	TREBLE:61	VOL:-15.4	Mix:50	Tail:OFF	Tail:ON
PRESENCE:72 VOLUME:70 INPUT:NORMAL SPEED:0							

056 : Blues FUZZ

This fuzz sound good for blues.

LEVEL 120

DETECT:EFXIN	FREQ:50	Gain:20	Boost:22	Speed:25	GAIN:33	LO:52	MOD:ON	PreD:69
Depth:100	Range:50	Boost:OFF	Color:2	Depth:60	BASS:34	HI:60	Time:384	Decay:37
THRSH:30	Dry:0	Tone:62	Tone:50	Modes:CHO	MIDDLE:44	BAL:100	F.B:37	Mix:29
Decay:0	VOL:80	VOL:90	VOL:100	RS	TREBLE:39	VOL:-16.0	Mix:50	Tail:OFF
PRESENCE:78 VOLUME:64 BRIGHT:OFF SPEED:0								

BANK 0 : PROG.M

057 : Prog.M CLN

This clean sound good for progressive metal.

COMP STONE PHASER ANALOG CHORUS HW100 IR LMT-76 CHORUS STEREO CHORUS PINGPONG DELAY PLATE

Sense:6 Color:1 Depth:60 GAIN:30 LO:45 Input:36 Depth:80 Depth:80 Time:570 PreD:30
 ATTCK:FAST Depth:60 Rate:30 BASS:64 HI:53 Ratio:4:1 Rate:20 Rate:30 F.B:21 Decay:40
 Tone:8 Rate:30 Tone:50 MIDDLE:16 BAL:100 REL:20 Tone:7 Tone:7 Mix:53 Mix:25
 VOL:65 RESO:0 Mix:50 TREBLE:72 VOL:-17.5 Output:37 Mix:34 Mix:50 Tail:OFF Tail:OFF
 PRESENCE:76
 VOLUME:67
 INPUT:BRILL

LEVEL

112

058 : Prog.M DRV

This drive sound good for progressive metal.

ZNR EP STOMP POLLEX IR PEDAL VOL. GUITAR GEQ 7 DELAY

DETCT:GTRIN Gain:64 GAIN:28 LO:53 VOL:100 100:1.0 Time:380
 Depth:100 Bass:-2 BASS:63 HI:55 Min:0 200:1.5 F.B:17
 THRSH:82 Treble:0 MIDDLE:40 BAL:100 Max:100 400:-0.5 Mix:40
 Decay:0 VOL:100 TREBLE:68 VOL:-16.7 Curve:A 800:-4.5 Tail:ON
 PRESENCE:31 VOLUME:62 1.6k:2.5
 3.2k:3.0
 6.4k:-0.5
 VOL:80

LEVEL

52

059 : Prog.M DBL

This doubling sound good for progressive metal.

NOISE GATE TS DRIVE PARAMETORIC EQ 7 HEAVEN IR PEDAL VOL. DELAY GEMINGS

DETCT:GTRIN Gain:0 Depth:60 GAIN:30 LO:45 Input:36 Depth:80 Depth:80
 Depth:100 Boost:OFF BASS:64 HI:53 Ratio:4:1 Rate:20 Rate:30
 THRSH:60 Tone:75 Tone:50 MIDDLE:16 BAL:100 REL:20 Tone:7 Tone:7
 Decay:0 VOL:72 Mix:50 TREBLE:72 VOL:-17.5 Output:37 Mix:34 Mix:50
 PRESENCE:76
 VOLUME:67
 INPUT:BRILL

LEVEL

100

060 : Prog.M LD

This lead tone good for progressive metal.

ZNR BLACK WAH TS DRIVE KRAMPUS IR PINGPONG DELAY HD HALL

DETCT:GTRIN FREQ:50 Gain:30 GAIN:65 LO:40 Time: J PreD:29
 Depth:100 Range:50 Boost:OFF BASS:29 HI:74 F.B:30 Decay:40
 THRSH:50 Dry:0 Tone:62 MIDDLE:58 BAL:100 Mix:35 Mix:40
 Decay:0 VOL:80 VOL:94 TREBLE:62 VOL:-17.4 Tail:ON Tail:ON
 PRESENCE:62
 VOLUME:56

LEVEL

59

061-100 : G11 PRESET PATCH MEMORY Version 1.00 (for Guitar Amp)

Preset patch memories 061–100 optimize tones for use connected to guitar amp inputs. Use these when connecting the G11 to a guitar amp that is adjusted for a clean tone.

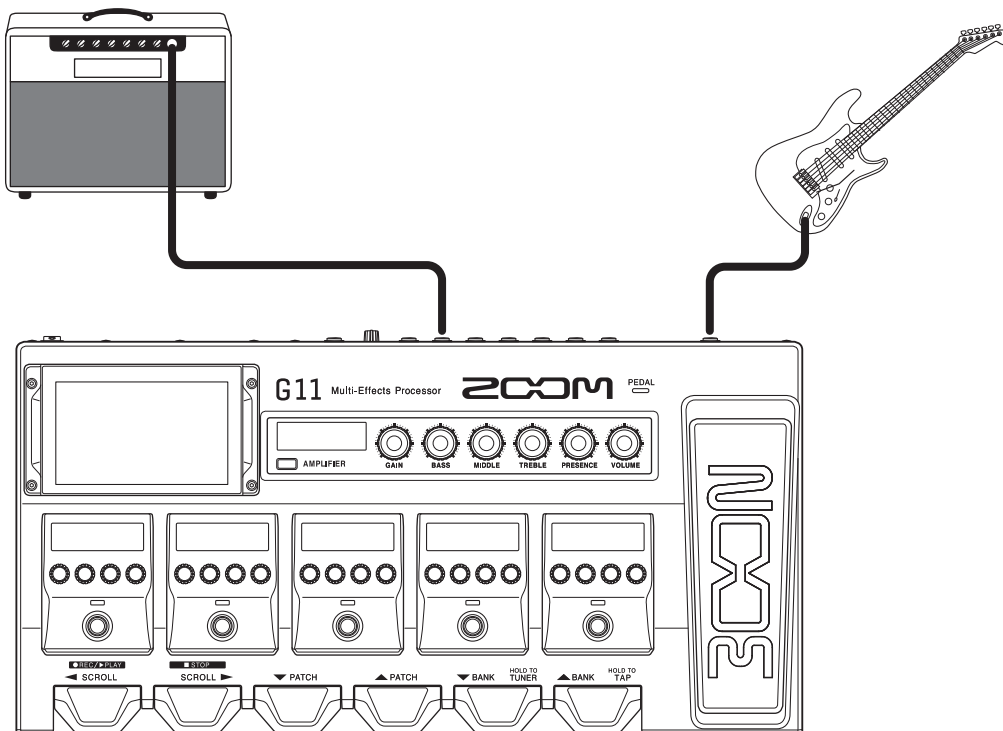

BANK P : FOR AMP 1

061 : KramLead

High gain long lead tones.

LEVEL: 60

ZNR DETCT:GTRIN Depth:100 THRSH:0 Decay:0	BLACK WAH FREQ:50 Range:50 Dry:0 VOL:80	WAVE SHAPER Gain:10 Shape:12 Comp:70 VOL:93	KRAMPUS GAIN:37 BASS:27 MIDDLE:61 TREBLE:61 PRESENCE:60 VOLUME:47	KP 4x12 MIC:OFF D57:D421:50 Hi:55 Lo:48	SOFT ECHO MOD:ON Time:362 F.B:19 Mix:44	CHAMBER PreD:85 Decay:48 Mix:18 Tail:ON
--	--	--	--	--	--	--

062 : PLX DRV_A

Straight drive sound for use with an amplifier.

LEVEL: 52

ZNR DETCT:GTRIN Depth:75 THRSH:20 Decay:0	PEDAL VOL. VOL:100 Min:0 Max:100 Curve:A	EP STOMP Gain:30 Bass:-5 Treble:-1 VOL:57	POLLEX GAIN:20 BASS:32 MIDDLE:52 TREBLE:53 PRESENCE:54 VOLUME:55	BGN 4x12 MIC:OFF D57:D421:50 Hi:52 Lo:45	TAPE ECHO Time:327 F.B:41 Mix:34 Tail:OFF	HALL PreD:23 Decay:7 Mix:22 Tail:OFF
--	---	--	---	---	--	---

063 : Plate Pit

This clean sound with a beautiful reverberation is added an octave up.

LEVEL: 52

ZNR DETCT:GTRIN Depth:75 THRSH:20 Decay:0	OPT COMP Drive:5 Lo:50 Hi:50 VOL:37	REDLOOM GAIN:37 BASS:60 MIDDLE:23 TREBLE:57 PRESENCE:50 VOLUME:54	POLY SHIFT Shift:24 Tone:60 Wet:30 Dry:80	RED 4x10 MIC:OFF D57:D421:50 Hi:75 Lo:65	ANALOG CHORUS Depth:84 Rate:50 Tone:50 Mix:79	PLATE PreD:9 Decay:52 Mix:38 Tail:OFF	PEDAL VOL. VOL:100 Min:0 Max:100 Curve:A
--	--	--	--	---	--	--	---

064 : DmCream

This creamy lead tone is perfect for fusion.

LEVEL: 49

ZNR DETCT:EFXIN Depth:100 THRSH:30 Decay:0	PEDAL VOL. VOL:100 Min:0 Max:100 Curve:A	OCT FUZZ Boost:15 Color:2 Tone:50 VOL:51	RC BOOST Gain:80 Bass:30 Treble:51 VOL:46	VELVET GAIN:47 BASS:29 MIDDLE:40 TREBLE:49 PRESENCE:58 VOLUME:50	GEMINOS Tight:46 Mode:MN-3 Wet:40 Dry:80	ANALOG DELAY Time:358 F.B:16 Mix:40 Tail:OFF	AMBIENCE PreD:28 Decay:68 Mix:74 Tail:ON
---	---	---	--	---	---	---	---

BANK Q : FOR AMP 2

065 : SwVibClean

Clean sound with a soft vibrato.

LEVEL 54

DETECT: GTRIN Depth:100 THRSH:16 Decay:50	THRSH:35 Ratio:4 ATTCK:7 VOL:45	GAIN:30 BASS:34 MIDDLE:27 TREBLE:44 PRESENCE:65 VOLUME:42 INPUT:BRILL	MIC:OFF D57:D421:50 Hi:50 Lo:50	Depth:29 Speed:43 Rise:75 Vol:80	Input:27 Ratio:8:1 REL:35 Output:40	Depth:75 Rate:25 Tone:7 Mix:50	Time:480 F.B:30 Mix:49 Tail:ON	PreD:81 Decay:45 Mix:62 Tail:OFF	VOL:100 Min:0 Max:100 Curve:A
--	--	---	--	---	--	---	---	---	--

066 : RazorPrncA

Extreme phase out sound for use with an amplifier.

LEVEL 50

DETECT:EPXIN Depth:100 THRSH:54 Decay:0	Mode:UP Sense:7 RESO:6 VOL:80	Gain:71 Edge:17 Lo:0 VOL:39	GAIN:31 BASS:54 MIDDLE:60 TREBLE:44 PRESENCE:53 VOLUME:51 BRIGHT:OFF SPEED:0	MIC:OFF D57:D421:50 Hi:45 Lo:52	PreD:4 Depth:62 Rate:3 RESO:3	VOL:100 Min:0 Max:100 Curve:A
--	--	--------------------------------------	---	--	--	--

067 : MudBlues_A

This crunch sound is perfect for classic blues for use with an amplifier.

LEVEL 50

DETECT:GTRIN Depth:75 THRSH:20 Decay:0	FREQ:50 Range:50 Dry:0 VOL:80	Gain:59 Bass:-1 Treb:-5 VOL:65	SUSTN:12 Tone:30 BAL:29 VOL:64	GAIN:42 BASS:64 MIDDLE:62 TREBLE:42 PRESENCE:52 VOLUME:60	MIC:OFF D57:D421:50 Hi:50 Lo:50	MOD:ON Time:314 F.B:33 Mix:19	PreD:28 Decay:11 Mix:60 Tail:OFF
---	--	---	---	--	--	--	---

068 : 7HVN-DST_A

Tight Djent sound good for 7 and 8 string guitars for use with an amplifier.

LEVEL 73

DETECT:GTRIN Depth:100 THRSH:91 Decay:0	Gain:0 Boost:OFF Q:16.0 Gain:6.0 VOL:72	FREQ:1.6K Q:16.0 Gain:6.0 VOL:80	GAIN:25 BASS:51 MIDDLE:22 TREBLE:61 PRESENCE:58 VOLUME:33	MIC:OFF D57:D421:75 Hi:50 Lo:50	PreD:4 Depth:61 Rate:41 ON/OFF:UNLATCH RESO:73 Mix:67 RST-F:50 LFO:RESET	Time:380 F.B:17 Mix:40 Tail:ON	VOL:100 Min:0 Max:100 Curve:A
--	---	---	--	--	---	---	--

BANK R : FOR AMP 3

069 : Rockabilly

This crunch sound is perfect for rockabilly.

PEDAL VOL.
 VOL:100
 Min:0
 Max:100
 Curve:A

SPRING
 PreD:1
 Decay:14
 Mix:13
 Tail:OFF

FD B-MAN
 GAIN:29
 BASS:0
 MIDDLE:43
 TREBLE:59
 PRESENCE:45
 VOLUME:60
 INPUT:BRIGHT

ZNR
 DETCT:EFXIN
 Depth:80
 THRSH:49
 Decay:0

SLAP BACK-D
 Time:134
 F.B:23
 Mix:40
 SubDv: J

ROOM
 PreD:60
 Decay:10
 Mix:40
 Tail:OFF

LEVEL
 50

070 : Memories

This gorgeous acoustic sound is added an octave up.

ZNR
 DETCT:EFXIN
 Depth:100
 THRSH:30
 Decay:0

Aco Sim.
 Top:80
 Body:90
 Tone:100
 VOL:80

POLY SHIFT
 Shift:12
 Tone:90
 Wet:42
 Dry:80

PEDAL VOL.
 VOL:100
 Min:0
 Max:100
 Curve:B

CHURCH
 PreD:0
 Decay:41
 Mix:54
 Tail:ON

FD TWINR
 GAIN:33
 BASS:42
 MIDDLE:44
 TREBLE:39
 PRESENCE:50
 VOLUME:67
 BRIGHT:OFF
 SPEED:0

BGN 4x12
 MIC:OFF
 D57:D421:50
 Hi:50
 Lo:50

LEVEL
 71

071 : ArpMachine

Rotary sound with pedal control of the speed.

ZNR
 DETCT:EFXIN
 Depth:65
 THRSH:30
 Decay:0

PEDAL ROTO
 Mode:FAST
 Drive:28
 BAL:45
 VOL:80

REDLOOM
 GAIN:45
 BASS:39
 MIDDLE:37
 TREBLE:68
 PRESENCE:40
 VOLUME:50

RACK COMP
 THRSH:29
 Ratio:6
 ATTK:6
 VOL:72

DELAY
 Time:560
 F.B:17
 Mix:13
 Tail:OFF

HD HALL
 PreD:29
 Decay:21
 Mix:29
 Tail:OFF

LEVEL
 88

072 : RectDRV

This high gain sound takes advantage of the amplifier character.

ZNR
 DETCT:EFXIN
 Depth:100
 THRSH:40
 Decay:0

BLACK WAH
 FREQ:50
 Range:50
 Dry:0
 VOL:80

TS DRIVE
 Gain:70
 Boost:OFF
 Tone:60
 VOL:71

RCT ORG
 GAIN:68
 BASS:21
 MIDDLE:52
 TREBLE:65
 PRESENCE:50
 VOLUME:36
 MODE:MDRN

RCT 4x12
 MIC:OFF
 D57:D421:50
 Hi:69
 Lo:50

GUITAR GEQ
 160:1.0
 400:0.5
 800:0.0
 9.2k:1.5
 6.4k:0.5
 12k:-0.5
 VOL:80
 CH SEL:LATCH

DELAY
 Time:700
 F.B:30
 Mix:35
 Tail:ON

CHURCH
 PreD:96
 Decay:36
 Mix:25
 Tail:ON

LEVEL
 55

BANK S : FOR AMP 4

073 : 70'sRhythm

This clean sound good for 70s style palm muting play.

LEVEL 43

ZNR DETCT:EFXIN Depth:60 THRSH:30 Decay:0	GRAY COMP SUSTN:28 Lo:60 Hi:68 VOL:40	FD TWINR GAIN:30 BASS:37 MIDDLE:0 TREBLE:65 PRESENCE:87 VOLUME:48 BRIGHT:OFF SPEED:0	FD 2x12 MIC:OFF D57:D421:21 Hi:56 Lo:50	LMT-76 Input:25 Ratio:4:1 REL:20 Output:53	PEDAL VOL VOL:100 Min:0 Max:100 Curve:A	DELAY Time:105 F.B:17 Mix:23 Tail:ON	SPRING PreD:1 Decay:20 Mix:10 Tail:OFF
--	--	---	--	---	--	---	---

074 : StoneBoy

This drive sound good for Stoner Rock rhythm guitar.

LEVEL 52

ZNR DETCT:EFXIN Depth:100 THRSH:30 Decay:0	PEDAL VOL VOL:100 Min:0 Max:100 Curve:A	OCTAVE OCT1:56 OCT2:0 Tone:8 Dry:61	ORG120 GAIN:26 BASS:50 MIDDLE:50 TREBLE:29 PRESENCE:32 VOLUME:45 INPUT:HI COLOR:4	BGN 4x12 MIC:OFF D57:D421:100 Hi:50 Lo:50	WAVE SHAPER Gain:55 Shape:28 Comp:60 VOL:80	DELAY Time:546 F.B:30 Mix:45 Tail:ON	PLATE PreD:9 Decay:39 Mix:35 Tail:ON
---	--	--	--	--	--	---	---

075 : PulseDelay

This tempo shift delay sound uses filter delay.

LEVEL 43

BLACK WAH FREQ:50 Range:50 Dry:0 VOL:80	BLACK OPT Comp:36 Lo:50 Hi:50 VOL:80	REDLOOM GAIN:27 BASS:42 MIDDLE:23 TREBLE:62 PRESENCE:69 VOLUME:61	RED 4x10 MIC:OFF D57:D421:70 Hi:65 Lo:50	SUPER CHORUS Depth:47 Rate:50 Tone:50 Mix:41	FILTER DELAY Time: J F.B:60 Mix:70 Tail:ON	HD HALL PreD:29 Decay:40 Mix:30 Tail:ON
--	---	--	---	---	---	--

076 : NYC Blue

Modern New York blues sound.

LEVEL 50

ZNR DETCT:EFXIN Depth:60 THRSH:30 Decay:0	PEDAL VOL VOL:100 Min:0 Max:100 Curve:A	COMP Sense:4 ATTACK: SLOW Tone:4 VOL:80	WAVE SHAPER Gain:16 Shape:45 Comp:0 VOL:70	FD TWINR GAIN:28 BASS:46 MIDDLE:49 TREBLE:42 PRESENCE:50 VOLUME:71 BRIGHT:OFF SPEED:0	MS 4x12 AL MIC:OFF D57:D421:72 Hi:40 Lo:50	SLAP BACK-D Time:99 F.B:30 Mix:23 SubDv: J	ROOM PreD:5 Decay:15 Mix:55 Tail:OFF
--	--	--	---	--	---	---	---

BANK T : FOR AMP 5

077 : UK Clean

This effective clean sound uses British combo amplifier.

UK30A, BLACK OPT, PHASER, UK 2x12, PEDAL VOL, DELAY, PARTICLE-R, PLATE, HOLD VERB

LEVEL: 40

GAIN:15 BASS:46 MIDDLE:30 TREBLE:50 PRESENCE:60 VOLUME:58 CUT:78 SPEED:0
 Comp:30 Lo:50 Hi:60 Rate:12 VOL:72
 Color:8 STG Depth:100 Rate:12 RESO:17
 MIC:OFF D57:D421:50 Hi:79 Lo:51
 VOL:100 Min:0 Max:100 Curve:A
 Time:7 F.B:30 Mix:44 Tail:ON
 Mode:STBL Decay:39 Mix:41 Tail:ON
 PreD:11 Decay:46 Mix:42 Tail:OFF
 PreD:79 Decay:70 Mix:37 Tail:ON
 Color:90 LoDMP:88 HiDMP:70 Hold:LATCH

078 : P Funk

The sound good for funky rhythm play.

PEDAL VOL, COMP, RESONANCE, FD TWINR, UK 2x12, SPRING

LEVEL: 50

VOL:100 Min:0 Max:100 Curve:A
 Sense:6 ATTACK:SLOW Tone:3 VOL:80
 Mode:UP Sense:6 RESO:4 VOL:85
 GAIN:33 BASS:31 MIDDLE:38 TREBLE:63 PRESENCE:61 VOLUME:62 BRIGHT:OFF SPEED:0
 MIC:OFF D57:D421:50 Hi:51 Lo:43
 PreD:1 Decay:12 Mix:15 Tail:OFF

079 : TXS Blues

This sound is perfect for Texas style blues.

ZNR, RC BOOST, FD DLXR, FDDX 1x12, PEDAL VOL, DELAY, SPRING

LEVEL: 98

DETECT:EFXIN Depth:70 THRSH:30 Decay:0
 Gain:26 Bass:5 Treble:59 VOL:57
 GAIN:86 BASS:37 MIDDLE:64 TREBLE:82 PRESENCE:62 VOLUME:70 INPUT:NORMAL SPEED:0
 MIC:OFF D57:D421:50 Hi:55 Lo:50
 VOL:100 Min:0 Max:100 Curve:A
 Time:92 F.B:17 Mix:25 Tail:OFF
 PreD:1 Decay:20 Mix:14 Tail:OFF

080 : Anthem

This lead tone good for majestic melodies.

ZNR, BLACK WAH, GOLD DRIVE, KRAMPUS, KP 4x12, MOD DELAY, CHURCH

LEVEL: 40

DETECT:EFXIN Depth:100 THRSH:30 Decay:0
 FREQ:50 Range:50 Dry:0 VOL:80
 Gain:16 Bass:49 Treble:61 VOL:45
 GAIN:72 BASS:59 MIDDLE:64 TREBLE:52 PRESENCE:63 VOLUME:70
 MIC:OFF D57:D421:49 Hi:50 Lo:44
 Time:384 F.B:19 Mix:22 Tail:ON
 PreD:84 Decay:38 Mix:25 Tail:OFF

BANK U : FOR AMP 6

081 : SciFiSyn_A

The synth like sound inspired by the universe for use with an amplifier.

ZNR
 DETCT:EFXIN
 Depth:70
 THRSH:30
 Decay:0

PEDAL VOL.
 VOL:100
 Min:0
 Max:100
 Curve:A

HOT SPICE
 Bend:11
 Buzz:57
 +1oct:36
 VOL:80

RING MODULATOR
 FREQ:40
 Tone:2
 BAL:50
 VOL:88

UK30A
 GAIN:74
 BASS:42
 MIDDLE:42
 TREBLE:0
 PRESENCE:26
 VOLUME:77
 CUT:78
 SPEED:0

CORONA TRI
 Depth:100
 Speed:25
 Tone:100
 Mix:86

SLOW ATTACK DELAY
 Swell:32
 Time:490
 F.B:75
 Mix:64

LEVEL 50

082 : CntryCLN_A

This clean sound with compression good for country music for amp use.

ZNR
 DETCT:EFXIN
 Depth:70
 THRSH:30
 Decay:0

GRAY COMP
 SUSTN:100
 Lo:60
 Hi:68
 VOL:28

FD TWINR
 GAIN:32
 BASS:24
 MIDDLE:43
 TREBLE:65
 PRESENCE:69
 VOLUME:30
 BRIGHT:OFF
 SPEED:0

FD 2x12
 MIC:OFF
 D57:D421:21
 Hi:50
 Lo:50

LMT-76
 Input:40
 Ratio:4:1
 REL:20
 Output:47

PEDAL VOL.
 VOL:100
 Min:0
 Max:100
 Curve:A

DELAY
 Time:94
 F.B:17
 Mix:38
 Tail:OFF

SPRING
 PreD:1
 Decay:20
 Mix:19
 Tail:OFF

LEVEL 52

083 : MudFuzz_A

The roaring fuzz sound is perfect for alternative rock for use with an amplifier.

ZNR
 DETCT:EFXIN
 Depth:75
 THRSH:20
 Decay:0

BLACK WAH
 FREQ:50
 Range:50
 Dry:0
 VOL:80

NYC MUFF
 SUSTN:29
 Tone:44
 BAL:46
 VOL:96

MUDDY
 GAIN:47
 BASS:94
 MIDDLE:67
 TREBLE:45
 PRESENCE:61
 VOLUME:48

MD 1x12
 MIC:OFF
 D57:D421:50
 Hi:50
 Lo:55

SOFT ECHO
 MOD:ON
 Time:367
 F.B:28
 Mix:35

HALL
 PreD:8
 Decay:9
 Mix:25
 Tail:OFF

LEVEL 45

084 : FD Chorus

This crisp clean sound using chorus.

FD TWINR
 GAIN:29
 BASS:38
 MIDDLE:48
 TREBLE:50
 PRESENCE:65
 VOLUME:50
 BRIGHT:ON
 SPEED:0

BLACK OPT
 Comp:18
 Lo:50
 Hi:60
 VOL:58

FD 2x12
 MIC:OFF
 D57:D421:50
 Hi:82
 Lo:50

CHORUS
 Depth:34
 Rate:25
 Tone:7
 Mix:50

DELAY
 Time:1
 F.B:29
 Mix:42
 Tail:ON

HD HALL
 PreD:90
 Decay:40
 Mix:40
 Tail:ON

PEDAL VOL.
 VOL:100
 Min:0
 Max:100
 Curve:A

LEVEL 48

BANK V : FOR AMP 7

085 : FriDrive

The drive sound as if to push the British stack amplifier.

LEVEL: 44

DETCT:EFXIN	Gain:0	GAIN:23	160:0.0	MIC:OFF	Time:450	PreD:1	VOL:100
Depth:100	Tone:50	BASS:33	400:1.0	D57:D421:50	F.B:30	Decay:30	Min:0
THRSH:42	BAL:53	MIDDLE:81	800:1.0	Hi:50	Mix:40	Mix:35	Max:100
Decay:0	VOL:100	TREBLE:52	3.2k:2.0	Lo:50	Tail:ON	Tail:ON	Curve:B
		PRESENCE:48	6.4k:0.0				
		VOLUME:55	12k:7.0				
			VOL:83				
			CH SEL:LATCH				

086 : 1959Crunch

This crunch sound good for backing parts.

LEVEL: 81

VOL:100	DETCT:EFXIN	Sense:3	GAIN:24	MIC:OFF	Time:560
Min:20	Depth:80	ATTCK:SLOW	BASS:60	D57:D421:50	F.B:34
Max:100	THRSH:30	Tone:5	MIDDLE:62	Hi:53	Mix:41
Curve:A	Decay:0	VOL:60	TREBLE:45	Lo:50	Tail:ON
			PRESENCE:49		
			VOLUME:63		
			INPUT2:24		

087 : Polyor

This synth like clean sound is added an octave up.

LEVEL: 63

Sense:6	GAIN:16	Shift:12	MIC:OFF	VOL:100	Rate:20	Time:560	PreD:96
ATTCK:FAST	BASS:30	Tone:90	D57:D421:50	Min:0	Width:30	F.B:64	Decay:49
Tone:6	MIDDLE:70	Wet:80	Hi:50	Max:100	Clip:0	Mix:56	Mix:51
VOL:80	TREBLE:36	Dry:80	Lo:50	Curve:B	VOL:100	Tail:ON	Tail:ON
	PRESENCE:30						
	VOLUME:60						
	INPUT2:OFF						

088 : WarmStrum

Warm clean sound with smooth compression.

LEVEL: 41

DETCT:EFXIN	VOL:100	Comp:50	Time:385	GAIN:37	MIC:OFF	Input:40	PreD:95
Depth:60	Min:0	Lo:52	F.B:16	BASS:67	D57:D421:50	Ratio:4:1	Decay:17
THRSH:30	Max:100	Hi:50	Mix:17	MIDDLE:52	Hi:62	REL:20	Mix:24
Decay:0	Curve:A	VOL:73	Tail:OFF	TREBLE:67	Lo:50	Output:36	Tail:OFF
				PRESENCE:85			
				VOLUME:49			

BANK W : FOR AMP 8

089 : ThickRiff

This high gain sound is perfect for metal riffs.

LEVEL 35

METAL WORLD	LMT-76	GUITAR GEQ	ZNR	KRAMPUS	KP 4x12	PEDAL VOL.
Gain:21 Bass:56 Treble:57 VOL:81	Input:40 Ratio:4:1 REL:20 Output:35	160:2.0 400:1.5 800:-2.0 3.2k:1.0 6.4k:0.5 12k:1.5 VOL:85 CH SEL:UnLATCH	DETCT:GTRIN Depth:100 THRSH:68 Decay:0	GAIN:82 BASS:66 MIDDLE:37 TREBLE:66 PRESENCE:68 VOLUME:56	MIC:OFF D57:D421:51 Hi:75 Lo:67	VOL:100 Min:0 Max:100 Curve:A

090 : SyncDLY_A

The sound that combines delays with different time settings for amp use.

LEVEL 52

PEDAL VOL.	ZNR	BLACK OPT	UK30A	UK 2x12	MOD DELAY	MOD DELAY	AMBIENCE
VOL:100 Min:0 Max:100 Curve:A	DETCT:EFXIN Depth:100 THRSH:30 Decay:0	Comp:50 Lo:50 Hi:50 VOL:76	GAIN:20 BASS:14 MIDDLE:44 TREBLE:66 PRESENCE:43 VOLUME:80 CUT:78 SPEED:0	MIC:OFF D57:D421:50 Hi:56 Lo:48	Time:J F.B:16 Mix:42 Tail:OFF	Time:J F.B:17 Mix:30 Tail:OFF	PreD:56 Decay:70 Mix:63 Tail:OFF

091 : R&B Clean

This smooth clean sound is perfect for R&B.

LEVEL 49

PEDAL VOL.	COMP	FD TWINR	MS 4x12 AL	ANALOG CHORUS	DELAY	SPRING
VOL:100 Min:1 Max:100 Curve:B	Sense:6 ATTCK:FAST Tone:2 VOL:80	GAIN:40 BASS:52 MIDDLE:51 TREBLE:63 PRESENCE:59 VOLUME:60 BRIGHT:OFF SPEED:0	MIC:OFF D57:D421:50 Hi:50 Lo:50	Depth:52 Rate:54 Tone:49 Mix:82	Time:560 F.B:21 Mix:27 Tail:OFF	PreD:1 Decay:14 Mix:32 Tail:OFF

092 : FuzzBend_A

Fuzz sound with pedal control of the pitch for use with an amplifier.

LEVEL 61

PEDAL MONO PITCH	ZNR	BLACK OPT	OCT FUZZ	SWEET DRIVE	REDLOOM	RED 4x10	TAP ECHO	PLATE
Bend:0 Color:+1 OCT Tone:10 Mode:UP	DETCT:EFXIN Depth:100 THRSH:55 Decay:0	Comp:50 Lo:50 Hi:50 VOL:76	Boost:65 Color:2 Tone:52 VOL:68	Gain:28 Tone:51 Focus:69 VOL:100	GAIN:50 BASS:15 MIDDLE:39 TREBLE:76 PRESENCE:68 VOLUME:46	MIC:OFF D57:D421:50 Hi:50 Lo:50	Time:J F.B:53 Mix:50 Tail:OFF	PreD:88 Decay:38 Mix:22 Tail:OFF

BANK X : FOR AMP 9

093 : ICE Clean

Clean tone with pitch shifted reverberations.

LEVEL 100

ZNR GRAY COMP HW100 HW 4x12 CLONE CHORUS ICE DELAY PARTICLE-R PEDAL VOL.

DETECT:GTRIN SUSTN:63 GAIN:19 MIC:OFF Depth:2 INTVL:OCT Mode:STBL VOL:100
 Depth:100 Lo:50 BASS:44 D57:D421:50 Rate:0 Time:J. Decay:0 Min:0
 THRSH:30 Hi:50 MIDDLE:49 Tone:100 F.B:45 Mix:30 Max:100
 Decay:25 VOL:46 TREBLE:73 PRESENCE:69 VOLUME:65 Curve:A
 INPUT:BRILL

094 : StayWavy

This sound good for rock ballads uses tremolo.

LEVEL 45

ZNR PEDAL VOL. EP STOMP TREMOLO HW100 MS 4x12 FD SPRING

DETECT:EPFIN VOL:100 Gain:25 Wave:TRI GAIN:39 MIC:OFF Color:0
 Depth:65 Min:0 Bass:-1 Depth:65 BASS:41 D57:D421:50 Lo:100
 THRSH:30 Max:100 Treble:1 Rate:50 MIDDLE:44 Hi:50 Hi:99
 Decay:0 Curve:A VOL:53 VOL:70 PRESENCE:56 VOLUME:36 Mix:30
 INPUT:BRILL

095 : FuzzyTail

This fuzz sound has a special sustain.

LEVEL 34

ZNR WAVE SHAPER FD B-MAN OPT COMP MS 4x12 PEDAL VOL. FILTER DELAY HD HALL

DETECT:GTRIN Gain:26 GAIN:20 Drive:7 MIC:OFF VOL:100 Time:563 PreD:108
 Depth:100 Shape:87 BASS:27 Lo:50 D57:D421:50 Min:0 F.B:40 Decay:21
 THRSH:40 Comp:37 MIDDLE:65 Hi:50 Max:100 Mix:64 Mix:23
 Decay:0 VOL:70 TREBLE:59 VOL:52 Lo:50 Curve:A Tail:OFF Tail:OFF
 PRESENCE:45 VOLUME:50 INPUT:BRIGHT

096 : Andromeda

This spacey clean sound uses reverse delay.

LEVEL 35

LMT-76 CHORUS REVERSE DELAY HD HALL REDLOOM HW 4x12 PEDAL VOL.

Input:30 Depth:12 Time:1000 PreD:105 GAIN:32 MIC:OFF VOL:100
 Ratio:4:1 Rate:16 F.B:20 Decay:100 BASS:44 D57:D421:56 Min:0
 REL:20 Tone:1 BAL:50 Tail:OFF MIDDLE:56 Hi:54 Lo:44
 Output:55 Mix:24 Tail:OFF Tail:OFF PRESENCE:55 VOLUME:72 Curve:A

BANK Y : FOR AMP 10

097 : ExtraLD

This smooth lead tone takes advantage of the amplifier character.

LEVEL: 45

ZNR	BLACK WAH	GOLD DRIVE	XTACY BL	BGN 4x12	SOFT ECHO	CHAMBER
DETECT:EFXIN Depth:100 THRSH:42 Decay:0	FREQ:40 Range:50 Dry:0 VOL:81	Gain:13 Bass:33 Treble:43 VOL:56	GAIN:52 BASS:70 MIDDLE:40 TREBLE:60 PRESENCE:64 VOLUME:61 STRCT:HI	MIC:OFF D57:D421:62 Hi:50 Lo:50	MOD:ON Time:386 F.B:31 Mix:31	PreD:40 Decay:23 Mix:30 Tail:ON

098 : Sequencer

Fuzzy sequence filter sound.

LEVEL: 47

RAZOR DRIVE	VELVET	SEQ FILTER	RED 4x10	NOISE GATE	HD HALL	PEDAL VOL.
Gain:33 Edge:93 Lo:39 VOL:15	GAIN:63 BASS:65 MIDDLE:50 TREBLE:38 PRESENCE:50 VOLUME:55	Step:8 PATTRN:7 Speed:28 RESO:6	MIC:OFF D57:D421:50 Hi:54 Lo:50	DETECT:EFXIN Depth:100 THRSH:85 Decay:0	PreD:29 Decay:21 Mix:29 Tail:OFF	VOL:100 Min:0 Max:100 Curve:A

099 : PLX-DST

Progressive metal sound with a mid scoop.

LEVEL: 52

ZNR	EP STOMP	POLLEX	PL 4x12	GUITAR GEQ 7	DELAY	PEDAL VOL.
DETECT:GTRIN Depth:100 THRSH:82 Decay:0	Gain:64 Bass:-2 Treble:0 VOL:100	GAIN:28 BASS:46 MIDDLE:41 TREBLE:67 PRESENCE:64 VOLUME:47	MIC:OFF D57:D421:0 Hi:50 Lo:50	100:0.0 200:0.0 400:-0.5 800:-4.5 1.6k:2.5 3.2k:1.0 6.4k:0.0 VOL:80	Time:380 F.B:17 Mix:40 Tail:ON	VOL:100 Min:0 Max:100 Curve:A

100 : DarkMatter

Psychedelic fuzz sound.

LEVEL: 66

ZNR	SLOW ATTACK	AUTO WAH	WAVE SHAPER	BG MK1	RED 4x10	WARP PHASER	TAPE ECHO	PEDAL VOL.	CHURCH
DETECT: Time:21 EFXIN Curve:10 Depth:100 THRSH:30 Decay:0	Mode:UP Sense:8 Shape:21 Tone:100 VOL:80	Gain:51 RESO:8 Comp:27 VOL:80	Gain:51 Shape:21 Comp:27 VOL:83	GAIN1:72 BASS:49 MIDDLE:56 TREBLE:53 PRESENCE:55 VOLUME:75 GAIN2:70	MIC:OFF D57:D421:50 Hi:44 Lo:50	Mode:BACK Speed:17 RESO:7 VOL:44	Time:560 F.B:64 Mix:56 Tail:ON	VOL:100 Min:0 Max:100 Curve:B	PreD:96 Decay:43 Mix:35 Tail:ON

101-240 : EMPTY



Patch memories 101–240 are empty.

241-340 : NEW GUITAR PRESET PATCH MEMORY (for PA System)

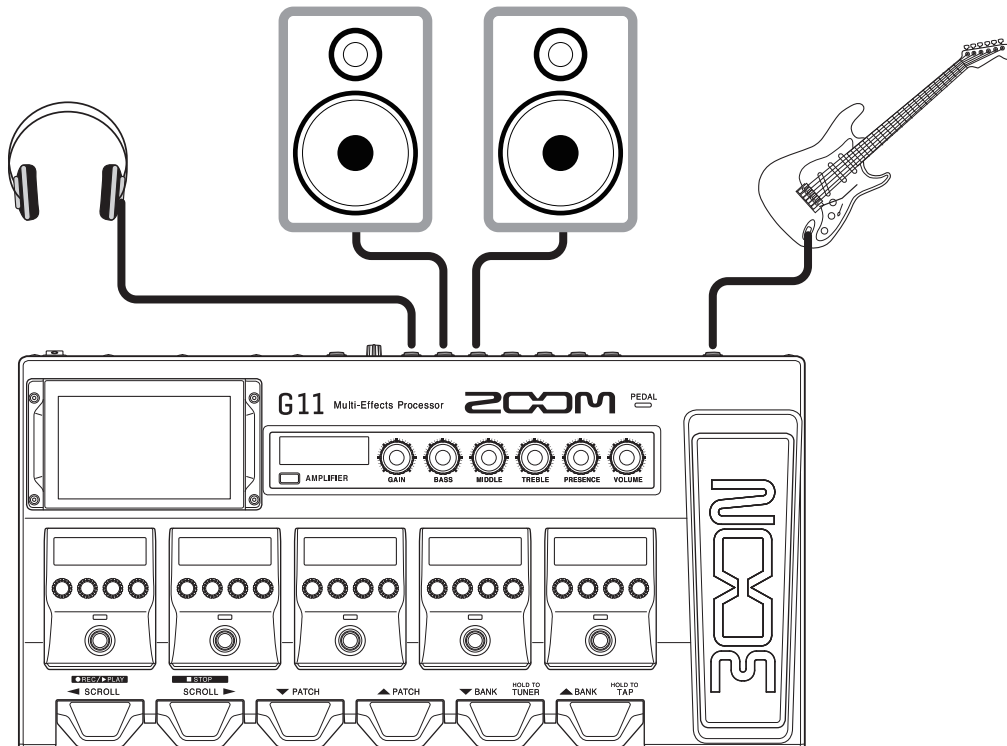

Preset patch memories 241–340 optimize tones for use connected to PA systems.

Use these when connecting the G11 to a PA system, powered monitor speakers or headphones.



To use this preset patch memory when connected to a guitar amp, turn off both the CABINET ( or  icon) and IR  .

Then adjust the EQ of the guitar amp as desired.

If the guitar input has a lot of noise, use noise reduction  and/or noise gate  .

BANK BI : ZOOM AMPS

241 : KRAMPUS

This versatile high-gain sound uses the ZOOM original KRAMPUS amp. Turn TS Drive on when it suits the phrase.

ZNR	BLACK WAH	TS DRIVE	KRAMPUS	IR	PARAMETRIC EQ	HALL	LEVEL 80
DETECT:EPXIN Depth:85 THRSH:30 Decay:0	FREQ:50 Range:50 Dry:0 VOL:80	Gain:2 Boost:OFF Tone:58 Vol:80	GAIN:47 BASS:47 MIDDLE:61 TREBLE:51 PRESENCE:63 VOLUME:56	LO:50 HI:50 BAL:100 VOL:-22.9	FREQ:6.3K Q:1.2 Gain:4.5 VOL:84	PreD:55 Decay:14 Mix:18 Tail:OFF	

242 : POLLEX

This crisp crunch sound uses the ZOOM original POLLEX amp. Try playing single-note riffs in the two-humbucker layout mix position. Turn GEMINOS on for a double-tracked sound.

ZNR	BG GRID	POLLEX	IR	ROOM	GEMINOS	PEDAL VOL.	LEVEL 80
DETECT:GTRIN Depth:100 THRSH:30 Decay:0	Gain:37 Tone:55 BAL:31 VOL:66	GAIN:50 BASS:39 MIDDLE:50 TREBLE:58 PRESENCE:77 VOLUME:49	LO:58 HI:50 BAL:100 VOL:-17.5	PreD:45 Decay:9 Mix:31 Tail:OFF	Tight:50 Mode:ST-2 Wet:86 Dry:85	VOL:100 Min:0 Max:100 Curve:A	

243 : REDROOM

This clean sound, which uses the ZOOM original REDROOM amp, is great for arpeggios. Try it with mix and halftone pickup settings. Turn PolyShift on to add an octave up.

REDROOM	IR	POLY SHIFT	STEREO CHORUS	ANALOG DELAY	BRIGHT HALL	LEVEL 80
GAIN:30 BASS:64 MIDDLE:44 TREBLE:49 PRESENCE:75 VOLUME:75	LO:56 HI:62 BAL:100 VOL:-19.2	Shift:12 Tone:70 Wet:29 Dry:70	Depth:80 Rate:30 Tone:7 Mix:51	Time:475 F.B:34 Mix:27 Tail:OFF	PreD:49 Decay:23 Tone:7 Mix:27	

244 : VELVET

Using the ZOOM original VELVET amp, this thick and creamy lead sound is great for flowing solos.

ZNR	BLACK WAH	TS DRIVE	VELVET	IR	TAPE ECHO	BRIGHT HALL	LEVEL 80
DETECT:GTRIN Depth:100 THRSH:34 Decay:0	FREQ:40 Range:50 Dry:0 VOL:80	Gain:4 Boost:OFF Tone:53 VOL:84	GAIN:63 BASS:58 MIDDLE:63 TREBLE:66 PRESENCE:62 VOLUME:54	LO:50 HI:55 BAL:100 VOL:-18.6	Time:389 F.B:37 Mix:23 Tail:ON	PreD:1 Decay:13 Tone:9 Mix:25	

BANK BJ : CLASSIC

245 : DLXTremolo

Combining FD DLXR with Tremolo, this sound is good for bluesy backing parts.

Gain:6
Tone:53
Voice:57
VOL:86

Mode:SLOW
Drive:20
BAL:50
VOL:80

Wave:TUBE
Depth:81
Rate:50
VOL:60

GAIN:79
BASS:42
MIDDLE:73
TREBLE:72
PRESENCE:74
VOLUME:91
INPUT:NORMAL
SPEED:0

LO:50
HI:50
BAL:100
VOL:-15.1

Time:395
F.B:29
Mix:25
Tail:OFF

PreD:1
Decay:10
Tone:7
Mix:54

LEVEL
80

246 : OctFuzz

This primitive fuzz sound uses OctFuzz. A unique upper octave sound can be achieved by lowering the guitar tone and playing single notes above the 12th fret position.

Boost:14
Color:2
Tone:50
VOL:55

FREQ:50
Range:50
Dry:0
VOL:80

GAIN:65
BASS:67
MIDDLE:65
TREBLE:45
PRESENCE:70
VOLUME:50

MIC:ON
D57:D421:
50
Hi:50
Lo:50

DETECT:GTRIN
Depth:53
THRSH:32
Decay:45

Time:560
F.B:27
Mix:39
Tail:OFF

PreD:1
Decay:14
Tone:5
Mix:41

LEVEL
90

247 : ORG Crunch

This straight crunch sound uses ORG120 and is good for backing parts with open chords.

FREQ:25
Depth:40
Dry:0
VOL:80

Gain:17
Tone:51
Focus:67
VOL:57

Speed:18
Depth:54
Mode:CHO
RS
VOL:80

GAIN:41
BASS:82
MIDDLE:65
TREBLE:56
PRESENCE:44
VOLUME:83
INPUT:HI
COLOR:2

LO:59
HI:50
BAL:100
VOL:-15.0

PreD:51
Decay:8
Tone:5
Mix:29

LEVEL
80

248 : Unchain

Combining KRAMPUS and KickFLNG, this flanger sound is good for backing parts using the bridge humbucker.

DETECT:GTRIN
Depth:100
THRSH:70
Decay:35

Gain:40
Bass:50
Treb:61
VOL:43

GAIN:77
BASS:78
MIDDLE:47
TREBLE:65
PRESENCE:65
VOLUME:70

LO:40
HI:64
BAL:100
VOL:-22.5

PreD:4
Depth:61
Rate:41
ON/OFF:LATCH
RESO:73
Mix:63
RST:F:50
LFO:RESET

Time:371
F.B:19
Mix:27
Tail:OFF

VOL:100
Min:0
Max:100
Curve:A

LEVEL
80

BANK BK : CRUNCH

249 : MS RoomMic

The room mic IR generates a realistic crunch sound with a sense of air. This provides a crunch sound that is sharp with single-coil pickups and wide-ranging with humbucker pickups.

LEVEL: 80

ZNR	MS1959	IR	IR	TAPE ECHO	ROOM	PEDAL VOL.
DETECT:EPXIN Depth:100 THRSH:30 Decay:0	GAIN:26 BASS:40 MIDDLE:66 TREBLE:56 PRESENCE:47 VOLUME:57 INPUT2:OFF	LO:49 HI:52 BAL:100 VOL:-11.4	LO:30 HI:43 BAL:4 VOL:-0.6	Time:382 F.B:28 Mix:24 Tail:OFF	PreD:8 Decay:12 Mix:34 Tail:OFF	VOL:100 Min:0 Max:100 Curve:A

250 : MudBlues

This crunch sound that is perfect for the blues uses the ZOOM original MUDDY amp. By adjusting the guitar volume, this sound can cover a wide range from backing to solo parts.

LEVEL: 80

ZNR	BLACK WAH	EP STOMP	MUDDY	IR	TAPE ECHO	SPRING
DETECT:GTRIN Depth:75 THRSH:20 Decay:0	FREQ:50 Range:50 Dry:0 VOL:80	Gain:34 Bass:5 Treble:-3 VOL:66	GAIN:73 BASS:77 MIDDLE:69 TREBLE:40 PRESENCE:52 VOLUME:45	LO:48 HI:60 BAL:100 VOL:-16.7	Time:314 F.B:34 Mix:16 Tail:OFF	PreD:1 Decay:11 Mix:19 Tail:OFF

251 : PugetPsy

This psychedelic drive sound uses WaveSHPR. Turning the guitar volume knob while playing brings out the unique tonal changes of the WaveSHPR.

LEVEL: 80

ZNR	BLACK WAH	WAVE SHAPER	HW100	TAPE ECHO	IR	GUITAR GEQ 7
DETECT:EPXIN Depth:100 THRSH:50 Decay:0	FREQ:50 Range:50 Dry:0 VOL:80	Gain:50 Shape:100 Comp:0 VOL:27	GAIN:100 BASS:65 MIDDLE:42 TREBLE:60 PRESENCE:66 VOLUME:27 INPUT:BRILL	Time:534 F.B:34 Mix:32 Tail:ON	LO:44 HI:60 BAL:65 VOL:-14.3	100:0.5 200:0.0 400:0.5 800:2.0 1.6k:0.5 3.2k:0.5 6.4k:5.5 VOL:80

252 : MasterDRV

This dry crunch sound uses FD MASTER and is good for playing power cords with the bridge humbucker.

LEVEL: 80

BLACK WAH	EP STOMP	CRY	FD MASTER	IR	DELAY	HD HALL
FREQ:50 Range:50 Dry:0 VOL:80	Gain:38 Bass:0 Treble:1 VOL:78	Range:7 RESO:8 Sense:7 BAL:100	GAIN:54 BASS:59 MIDDLE:67 TREBLE:63 PRESENCE:73 VOLUME:57 FAT:OFF	LO:50 HI:50 BAL:100 VOL:-15.1	Time: J F.B:5 Mix:28 Tail:OFF	PreD:120 Decay:45 Mix:21 Tail:OFF

BANK BL : DRIVE

253 : MassiveDZ

This drive sound with DZ DRV is perfect for chopping heavy riffs using the bridge humbucker.

LEVEL: 80

ZNR DETCT:GTRIN Depth:100 THRSH:50 Decay:0	PEDAL MONO PITCH Bend:0 Color:+1 OCT Tone:10 Mode:UP	GOLD DRIVE Gain:9 Bass:50 Treb:56 VOL:64	DZ DRIVE GAIN:76 BASS:50 MIDDLE:70 TREBLE:74 PRESENCE:49 VOLUME:80 DEEP:6 MID CUT:21	IR LO:45 HI:50 BAL:87 VOL:-17.2	PHASE DELAY Time:J F.B:24 Mix:19 Tail:ON COLOR:4 STG DEPTH:100 RATE:J x4 RESO:48	BRIGHT HALL PreD:57 Decay:10 Tone:5 Mix:29
---	---	---	---	--	---	---

254 : XtasyDRV

This drive sound with XtasyBlue clearly brings out the character of the pickup position and can be used for a wide range of playing.

LEVEL: 80

WAH 100 FREQ:25 Depth:40 Dry:0 VOL:80	ZNR DETCT:EFXIN Depth:100 THRSH:30 Decay:0	RC BOOST Gain:38 Bass:49 Treb:52 VOL:64	XTACY BL GAIN:62 BASS:85 MIDDLE:64 TREBLE:65 PRESENCE:72 VOLUME:47 STRCT:HI	IR LO:64 HI:59 BAL:100 VOL:-15.5	DETUNE Cent:11 PreD:0 Tone:6 Mix:50	PINGPONG DELAY Time:J F.B:13 Mix:19 Tail:OFF	BRIGHT HALL PreD:53 Decay:10 Tone:2 Mix:29
--	---	--	---	---	--	---	---

255 : Djent7

This DJENT style high-gain sound uses the ZOOM original 7 HEAVEN amp model and matches contemporary guitars with 7 and 8 strings. Turn VinFLNGR on when it suits the phrase.

LEVEL: 80

NOISE GATE DETCT:GTRIN Depth:100 THRSH:60 Decay:0	TS DRIVE Gain:0 Boost:OFF Tone:75 VOL:72	PARAMETRIC EQ FREQ:1.6K Q:16.0 Gain:6.0 VOL:80	7 HEAVEN GAIN:25 BASS:61 MIDDLE:33 TREBLE:64 PRESENCE:70 VOLUME:48	IR LO:52 HI:56 BAL:100 VOL:-15.6	PARAMETRIC EQ FREQ:8.0K Q:0.6 Gain:1.0 VOL:80	VINTAGE FLANGER PreD:4 Depth:34 Rate:10 RESO:6	PEDAL VOL. VOL:100 Min:0 Max:100 Curve:A
--	---	---	---	---	--	---	---

256 : RectoPan

This metal sound, which uses the GEMINOS stereo double tracking effect and a heavy Recti ORG, is perfect for backing parts using the bridge humbucker.

LEVEL: 80

ZNR DETCT:EFXIN Depth:100 THRSH:30 Decay:0	TS DRIVE Gain:0 Boost:OFF Tone:57 VOL:77	RCT ORG GAIN:70 BASS:57 MIDDLE:54 TREBLE:59 PRESENCE:56 VOLUME:70 MODE:VNTG	IR LO:58 HI:50 BAL:100 VOL:-14.8	PARAMETRIC EQ FREQ:100 Q:0.6 Gain:-3.5 VOL:80	GEMINOS Tight:49 Mode:ST-1 Wet:80 Dry:86	HALL PreD:20 Decay:7 Mix:17 Tail:ON	PEDAL VOL. VOL:100 Min:0 Max:100 Curve:A
---	---	---	---	--	---	--	---

BANK BM : CLEAN

257 : TransAC

This transparent acoustic guitar sound, which uses Aco.Sim and LMT-76, covers a range of playing from strumming to fingerpicking. This is effective with single-coil neck pickups.

LEVEL: 97

DETCT:EFXIN	160:-1.0	Top:80	Input:40	Depth:40	Time:463	PreD:77	VOL:100
Depth:50	400:2.0	Body:94	Ratio:4:1	Rate:25	F.B:25	Decay:12	Min:0
THRSH:30	800:0.5	Tone:86	REL:20	Tone:6	Mix:22	Mix:15	Max:100
Decay:0	3.2k:0.0	VOL:61	Output:38	Mix:13	Tail:ON	Tail:OFF	Curve:A
	6.4k:-1.5						
	12k:3.0						
	VOL:80						
	CH SEL:LATCH						

258 : MATCH CIn

Combining MATCH30 and AIR, this glossy clean sound is good for strumming with guitars that have single-coil pickups.

LEVEL: 80

FREQ:50	Gain:22	GAIN:23	LO:50	Time:384	Size:20	PreD:5
Range:50	Bass:45	BASS:36	HI:50	F.B:24	REF:5	Decay:10
Dry:0	Treble:53	MIDDLE:52	BAL:100	Mix:26	Mix:60	Tone:7
VOL:80	VOL:30	TREBLE:71	VOL:-17.2	Tail:OFF	Tail:OFF	Mix:60
		PRESENCE:52				
		VOLUME:63				
		GAIN2:OFF				
		CUT:0				

259 : CntryCLN

This clean sound, which uses GrayComp, is great for country licks with chicken picking using a single-coil pickup in the bridge position.

LEVEL: 80

DETCT:GTRIN	SUSTN:100	GAIN:32	LO:49	Input:40	Time:109	PreD:1	VOL:100
Depth:75	Lo:60	BASS:37	HI:60	Ratio:4:1	F.B:0	Decay:12	Min:0
THRSH:30	Hi:68	MIDDLE:63	BAL:100	REL:20	Mix:35	Mix:24	Max:100
Decay:0	VOL:28	TREBLE:58	VOL:-16.5	Output:46	Tail:OFF	Tail:OFF	Curve:A
		PRESENCE:71					
		VOLUME:59					
		BRIGHT:OFF					
		SPEED:0					

260 : WorshipAMB

This ambient sound, which uses the Church effect, is perfect for playing long chords in gospel music.

LEVEL: 80

DETCT:EFXIN	Shift:12	Depth:94	GAIN:23	LO:51	VOL:100	Time:7	PreD:0
Depth:100	Fine:0	Rate:37	BASS:47	HI:63	Min:0	F.B:24	Decay:33
THRSH:30	Tone:3	Tone:50	MIDDLE:57	BAL:100	Max:100	Mix:33	Mix:37
Decay:0	BAL:34	Mix:50	TREBLE:57	VOL:-13.5	Curve:A	Tail:OFF	Tail:ON
			PRESENCE:80				
			VOLUME:59				
			INPUT2:OFF				

BANK BN : US ROCK

261 : PanOHalen

This hard rock sound is perfect for playing with the bridge humbucker. It is inspired by a massive hit album in 1984 from a US West Coast band with a super guitarist who had a super smile.

LEVEL 80

ZNR	7 HEAVEN	RCT 4x12	GUITAR GEQ	STEREO CHORUS	DELAY	HALL
DETCT:EFXIN Depth:100 THRSH:30 Decay:0	GAIN:48 BASS:29 MIDDLE:43 TREBLE:66 PRESENCE:57 VOLUME:33	MIC:OFF D57:D421:50 Hi:72 Lo:46	160:0.0 400:0.5 800:0.0 3.2k:0.0 6.4k:6.5 12k:0.0 VOL:80 CH SEL:LATCH	Depth:80 Rate:1 Tone:7 Mix:10	Time:366 F.B:23 Mix:33 Tail:OFF	PreD:59 Decay:12 Mix:30 Tail:OFF

262 : The 'Cuda

This flanger sound, which is good with the bridge humbucker, is inspired by a 1977 hit song by an American band with two sisters.

LEVEL 80

VINTAGE FLANGER	HW100	HW 4x12	LMT-76	PEDAL VOL.	PINGPONG DELAY
PreD:3 Depth:47 Rate:4 RESO:3	GAIN:100 BASS:29 MIDDLE:80 TREBLE:63 PRESENCE:69 VOLUME:25 INPUT:BRILL	MIC:OFF D57:D421:50 Hi:53 Lo:50	Input:40 Ratio:4:1 REL:20 Output:33	VOL:100 Min:0 Max:100 Curve:A	Time:81 F.B:0 Mix:34 Tail:OFF

263 : Exit Light

Inspired by a popular song that received the Best Hard Rock/Metal Performance Grammy Award in 1992, this modern high-gain sound is perfect with the bridge humbucker.

LEVEL 80

ZNR	COMP	EP STOMP	7 HEAVEN	RCT 4x12	GUITAR GEQ
DETCT:GTRIN Depth:100 THRSH:43 Decay:0	Sense:6 ATTCK:SLOW Tone:0 VOL:80	Gain:17 Bass:4 Treb:6 VOL:62	GAIN:60 BASS:72 MIDDLE:10 TREBLE:66 PRESENCE:54 VOLUME:39	MIC:OFF D57:D421:50 Hi:52 Lo:83	160:0.0 400:0.0 800:0.0 3.2k:0.0 6.4k:5.0 12k:0.0 VOL:80 CH SEL:LATCH

264 : FlyHigh

This distortion sound perfect for humbuckers is inspired by the slide guitar part in a famous track on the 1973 debut studio album from a southern rock band that caught fire with its triple guitar lineup.

LEVEL 80

ZNR	TS DRIVE	PHASER	MS450s	MS 4x12 AL	PEDAL VOL.	SPRING
DETCT:GTRIN Depth:100 THRSH:19 Decay:0	Gain:74 Boost:OFF Tone:57 VOL:82	Color:INV 8 Depth:88 Rate:4 RESO:50	GAIN:53 BASS:44 MIDDLE:70 TREBLE:18 PRESENCE:22 VOLUME:61 INPUT2:OFF	MIC:OFF D57:D421:20 Hi:50 Lo:50	VOL:100 Min:0 Max:100 Curve:A	PreD:1 Decay:20 Mix:33 Tail:OFF

BANK BO : UK ROCK

265 : SOS Bottle

Inspired by the opening track from the 1979 second album released by an English trio known for adding elements of reggae to rock, this clean sound is great for single-coil pickups.

ZNR
 DETCT:GTRIN
 Depth:100
 THRSH:9
 Decay:0

COMP
 Sense:6
 ATTK: SLOW
 Tone:9
 VOL:80

SWEET DRIVE
 Gain:40
 Tone:50
 Focus:52
 VOL:62

STEREO CHORUS
 Depth:80
 Rate:26
 Tone:7
 Mix:100

MATCH30
 GAIN:22
 BASS:11
 MIDDLE:62
 TREBLE:74
 PRESENCE:78
 VOLUME:46
 GAIN2:OFF
 CUT:0

MA 2x12
 MIC:OFF
 D57:D421:50
 Hi:50
 Lo:31

LEVEL: 80

266 : RunRunRun

This echo and crunch sound suitable for single-coil pickups is inspired by the sound of a 1979 double album that was a massive hit in the USA for an English prog rock band.

COMP
 Sense:2
 ATTK: SLOW
 Tone:6
 VOL:82

EP STOMP
 Gain:39
 Bass:-1
 Treble:1
 VOL:83

VINTAGE FLANGER
 PreD:4
 Depth:6
 Rate:2
 RESO:5

FD B-MAN
 GAIN:22
 BASS:27
 MIDDLE:82
 TREBLE:40
 PRESENCE:66
 VOLUME:36
 INPUT: BRIGHT

BM 4x10
 MIC:OFF
 D57:D421:50
 Hi:50
 Lo:50

MDD DELAY
 Time:380
 F.B:50
 Mix:50
 Tail:OFF

TAPE ECHO
 Time:507
 F.B:5
 Mix:40
 Tail:OFF

HD HALL
 PreD:81
 Decay:45
 Mix:20
 Tail:OFF

LEVEL: 80

267 : SultanOJaz

Inspired by the unique fingerpicking style in a song the guitarist also sang about the lamentations of a pub rock band on his band's 1978 album, this sound is perfect for single-coil pickups.

COMP
 Sense:1
 ATTK: SLOW
 Tone:10
 VOL:82

FD TWINR
 GAIN:34
 BASS:42
 MIDDLE:44
 TREBLE:39
 PRESENCE:65
 VOLUME:35
 BRIGHT:ON
 SPEED:0

FD 2x12
 MIC:OFF
 D57:D421:50
 Hi:71
 Lo:50

GUITAR GEQ
 160:0.0
 400:6.0
 800:0.0
 3.2k:6.5
 6.4k:0.0
 12k:2.5
 VOL:80
 CH SEL:LATCH

PEDAL VOL
 VOL:100
 Min:0
 Max:100
 Curve:A

BRIGHT ROOM
 PreD:5
 Decay:10
 Tone:7
 Mix:52

PLATE
 PreD:151
 Decay:29
 Mix:14
 Tail:OFF

LEVEL: 80

268 : RedFrames

This clean sound is good for humbucker pickups. It is inspired by the second track on the album released in 1981 by an English progressive rock band led by a guitarist known for repeating phrases with unparalleled perfection and playing while seated.

ZNR
 DETCT:EFXIN
 Depth:100
 THRSH:30
 Decay:0

COMP
 Sense:6
 ATTK: SLOW
 Tone:9
 VOL:80

STEREO CHORUS
 Depth:80
 Rate:26
 Tone:7
 Mix:100

MATCH30
 GAIN:18
 BASS:11
 MIDDLE:62
 TREBLE:74
 PRESENCE:66
 VOLUME:53
 GAIN2:OFF
 CUT:0

MA 2x12
 MIC:OFF
 D57:D421:13
 Hi:50
 Lo:31

PEDAL VOL
 VOL:100
 Min:0
 Max:100
 Curve:A

PINGPONG DELAY
 Time:68
 F.B:30
 Mix:40
 Tail:OFF

HALL
 PreD:71
 Decay:9
 Mix:23
 Tail:OFF

LEVEL: 80

BANK BP : LEGEND

269 : PlainCrazy

This crunch sound was inspired by a hard rock number written with the bassist from a 1974 album by an English band. The famous guitarist is known for playing a guitar he built with his father using a sixpence coin as well as for having a PhD in astrophysics.

ZNR
 DETCT:GTRIN
 Depth:100
 THRS:12
 Decay:0

EP STOMP
 Gain:37
 Bass:-6
 Treble:4
 VOL:62

UK30A
 GAIN:92
 BASS:31
 MIDDLE:52
 TREBLE:60
 PRESENCE:66
 VOLUME:72
 CUT:63
 SPEED:0

UK 2x12
 MIC:OFF
 D57:D421:50
 Hi:50
 Lo:50

IR
 LO:50
 HI:55
 BAL:51
 VOL:-19.5

GEMINOS
 Tight:46
 Mode:ST-1
 Wet:93
 Dry:81

LEVEL 80

270 : TheTower

This dirty distortion sound is perfect for rhythm guitar and bluesy solos. The inspiration is a song from the double album that was the last released by a famous left-handed guitarist known for playing with #9th chords and appearing at the 1969 Woodstock Festival.

CHROME WAH
 FREQ:50
 Range:50
 Dry:0
 VOL:80

MS1959
 GAIN:82
 BASS:50
 MIDDLE:50
 TREBLE:60
 PRESENCE:63
 VOLUME:58
 INPUT2:OFF

MS 4x12 AL
 MIC:OFF
 D57:D421:50
 Hi:50
 Lo:50

TAPE ECHO
 Time:383
 F.B:36
 Mix:24
 Tail:OFF

SPRING
 PreD:1
 Decay:20
 Mix:21
 Tail:OFF

LEVEL 80

271 : Blisters

This distortion sound is perfect for single-coil guitars. The inspiration is a track from the ninth album released in 1968 by a famous four-man English band from Liverpool known originally for their mushroom-cut hairstyles. This sound also had a large influence on heavy metal.

BG GRID
 Gain:41
 Tone:0
 BAL:100
 VOL:74

FD TWINR
 GAIN:84
 BASS:0
 MIDDLE:85
 TREBLE:14
 PRESENCE:25
 VOLUME:53
 BRIGHT:ON
 SPEED:0

GUITAR GEQ
 160:-12.0
 400:-6.0
 800:0.0
 3.2k:8.0
 6.4k:-5.5
 12k:-12.0
 VOL:86
 CH SEL:LATCH

PARAMETORIC EQ
 FREQ:2.0K
 Q:4.3
 Gain:6.0
 VOL:68

PEDAL VOL.
 VOL:100
 Min:0
 Max:100
 Curve:A

LEVEL 80

272 : IfYouWanna

Optimal for single-coil guitars, this sound creates a psychedelic vibe. The inspiration is a song about a drug from the 1977 album of a guitarist known as Slowhand who has a great singing voice.

TS DRIVE
 Gain:8
 Boost:OFF
 Tone:57
 VOL:43

MS45os
 GAIN:100
 BASS:30
 MIDDLE:70
 TREBLE:0
 PRESENCE:0
 VOLUME:45
 INPUT2:OFF

MS 4x12 GB
 MIC:OFF
 D57:D421:21
 Hi:38
 Lo:50

THE VIBE
 Speed:3
 Depth:52
 Mode:VIBRT
 VOL:82

STEREO CHORUS
 Depth:80
 Rate:30
 Tone:7
 Mix:20

PEDAL VOL.
 VOL:100
 Min:0
 Max:100
 Curve:A

ROOM
 PreD:5
 Decay:10
 Mix:60
 Tail:OFF

LEVEL 80

BANK BQ : R&R

273 : YouSoGotIt

This metallic low-gain distortion is good for playing riffs with humbucker pickups. This sound is inspired by the 1964 original by an English band from London, but a cover was also a big hit on the debut album of a West Coast American hard rock band in 1978.

RAZOR DRIVE

Gain:13
Edge:46
Lo:48
VOL:80

FD TWINR

GAIN:41
BASS:14
MIDDLE:33
TREBLE:39
PRESENCE:64
VOLUME:46
BRIGHT:ON
SPEED:0

GUITAR GEQ

160:0.0
400:0.0
800:0.0
3.2k:0.0
6.4k:6.5
12k:1.0
VOL:80
CH SEL:LATCH

PEDAL VOL.

VOL:100
Min:0
Max:100
Curve:A

ROOM

PreD:27
Decay:7
Mix:32
Tail:OFF

LEVEL

80

274 : TheOne

This distortion sound is good for playing backing parts with open chords. A hit song from the fifth album released in 1987 by an American alternative band that was inducted into the Rock & Roll Hall of Fame in 2007 is the inspiration.

EP STOMP

Gain:4
Bass:0
Treble:-2
VOL:84

UK30A

GAIN:56
BASS:49
MIDDLE:50
TREBLE:73
PRESENCE:59
VOLUME:59
CUT:0
SPEED:0

UK 2x12

MIC:OFF
D57:D421:50
Hi:50
Lo:50

GUITAR GEQ

160:0.0
400:0.0
800:0.0
3.2k:0.0
6.4k:0.5
12k:3.5
VOL:99
CH SEL:LATCH

PINGPONG DELAY

Time:238
F.B:6
Mix:26
Tail:OFF

HD HALL

PreD:81
Decay:45
Mix:20
Tail:OFF

LEVEL

80

275 : Odd Brew

This psychedelic vintage distortion is good for guitars with humbucker pickups. This sound is inspired by the first song on the second studio album released in 1967 by a London trio that is said to have created the foundation for later hard rock by fusing blues rock and psychedelic rock in the late 60s.

HG THR TTL

Gain:3
Tone:4
MdCut:63
VOL:93

FD TWINR

GAIN:22
BASS:31
MIDDLE:100
TREBLE:100
PRESENCE:100
VOLUME:43
BRIGHT:ON
SPEED:0

GUITAR GEQ 7

100:0.0
200:0.0
400:0.0
800:0.0
1.6k:0.0
3.2k:0.0
6.4k:7.5
VOL:80

SPRING

PreD:1
Decay:13
Mix:50
Tail:OFF

PEDAL VOL.

VOL:100
Min:0
Max:100
Curve:A

LEVEL

80

276 : SonicRokit

Inspired by the second track on the 1988 album released by a New York alternative rock band known for beautiful guitar noise, this distortion sound for rhythm playing has a gritty texture.

SWEET DRIVE

Gain:17
Tone:31
Focus:56
VOL:62

BG GRID

Gain:17
Tone:46
BAL:100
VOL:40

MATCH30

GAIN:17
BASS:19
MIDDLE:50
TREBLE:58
PRESENCE:84
VOLUME:59
GAIN2:OFF
CUT:0

GUITAR GEQ

160:9.0
400:6.0
800:5.0
3.2k:4.5
6.4k:4.5
12k:2.5
VOL:80
CH SEL:LATCH

MD 1x12

MIC:ON
D57:D421:50
Hi:68
Lo:50

ROOM

PreD:49
Decay:9
Mix:37
Tail:OFF

LEVEL

80

BANK BR : METAL

277 : WildTrain

This high-gain sound for lead playing suits humbucker pickups. The inspiration is the guitar sound on the first solo album by a vocalist who has nicknames that include "the madman" and debuted with an English band that is considered to be a progenitor of heavy metal with songs on themes of black magic and the occult.

LEVEL 80

ZNR DETCT:GTRIN Depth:100 THRSH:11 Decay:0	OPT COMP Drive:7 Lo:50 Hi:50 VOL:60	GOLD DRIVE Gain:70 Bass:0 Treble:69 VOL:43	MS800 GAIN:77 BASS:8 MIDDLE:90 TREBLE:73 PRESENCE:30 VOLUME:66 INPUT:HI	MS 4x12 GB MIC:OFF D57:D421:50 Hi:50 Lo:50	CHORUS Depth:40 Rate:12 Tone:7 Mix:20	PINGPONG DELAY Time:78 F.B:8 Mix:27 Tail:OFF
---	--	---	---	---	--	---

278 : StukByJira

Use the pedal for a pitch bend effect with this high-gain sound inspired by a French metal band nominated for the Best Metal Performance Grammy Award in 2017.

LEVEL 80

PEDAL MOND PITCH Bend:0 Color:+1 OCT Tone:10 Mode:UP	METAL WORLD Gain:15 Bass:50 Treble:50 VOL:18	COMP Sense:6 ATTCK:SLW Tone:9 VOL:80	RCT ORG GAIN:74 BASS:11 MIDDLE:86 TREBLE:67 PRESENCE:62 VOLUME:28 MODE:MDRN	RCT 4x12 MIC:OFF D57:D421:50 Hi:72 Lo:55	NOISE GATE DETCT:GTRIN Depth:100 THRSH:54 Decay:0	GUITAR GEQ 160:0.5 400:0.0 800:0.5 3.2k:0.0 6.4k:1.5 12k:0.5 VOL:80 CH SEL:LATCH
---	---	---	---	---	--	---

279 : StukMoshin

This distortion sound ideal for crunchy riffs is inspired by the third album released in 1987 by one of the big four thrash metal bands. Their unique guitarist is known for his long beard, short pants and guitar with only 14 frets.

LEVEL 80

ZNR DETCT:GTRIN Depth:100 THRSH:15 Decay:0	GOLD DRIVE Gain:49 Bass:25 Treble:18 VOL:65	RCT ORG GAIN:28 BASS:19 MIDDLE:11 TREBLE:48 PRESENCE:49 VOLUME:51 MODE:MDRN	MS 4x12 MIC:ON D57:D421:50 Hi:43 Lo:50	GUITAR GEQ 7 100:-5.0 200:2.5 400:-4.5 800:-2.5 1.6k:-3.0 3.2k:3.5 6.4k:5.0 VOL:92	PEDAL VOL VOL:100 Min:0 Max:100 Curve:A
---	--	---	---	---	--

280 : Scopiane

This is a lead sound that is perfect for guitars with humbucker pickups. It was inspired by the second track on the ninth studio album released in 1984 by a hard rock band that participated in the first Monsters of Rock and is from the former West Germany.

LEVEL 80

ZNR DETCT:GTRIN Depth:100 THRSH:30 Decay:0	SWEET DRIVE Gain:35 Tone:100 Focus:77 VOL:54	RCT ORG GAIN:58 BASS:2 MIDDLE:94 TREBLE:58 PRESENCE:68 VOLUME:53 MODE:VNTG	MS 4x12 MIC:OFF D57:D421:50 Hi:50 Lo:50	GUITAR GEQ 7 100:-6.5 200:-5.0 400:0.0 800:0.0 1.6k:0.0 3.2k:6.0 6.4k:2.5 VOL:80	DELAY Time:J F.B:24 Mix:20 Tail:OFF	BRIGHT HALL PreD:24 Decay:11 Tone:2 Mix:38
---	---	--	--	---	--	---

BANK BS : POPS

281 : Pops CLN

Using REDLOOM and AnalogCho, this clean sound is good for arpeggios and strumming with guitars that have single-coil pickups.

LEVEL: 80

ZNR	TS DRIVE	ANALOG CHORUS	REDLOOM	IR	PEDAL VOL	DELAY	BRIGHT HALL
DETECT:EFXIN Depth:100 THRSH:30 Decay:0	Gain:10 Boost:OFF Tone:40 Vol:50	Depth:51 Rate:30 Tone:50 Mix:100	GAIN:28 BASS:59 MIDDLE:51 TREBLE:56 PRESENCE:75 VOLUME:65	LO:50 HI:63 BAL:100 VOL:-18.1	VOL:100 Min:0 Max:100 Curve:A	Time: J F.B:30 Mix:60 Tail:ON	PreD:23 Decay:3 Tone:9 Mix:15

282 : Pops DRV

Using REDLOOM, this drive sound is good for backing parts played with guitars that have single-coil pickups.

LEVEL: 80

ZNR	TS DRIVE	ANALOG CHORUS	REDLOOM	IR	PEDAL VOL	DELAY	BRIGHT HALL
DETECT:EFXIN Depth:100 THRSH:30 Decay:0	Gain:26 Boost:OFF Tone:51 VOL:55	Depth:70 Rate:20 Tone:48 Mix:92	GAIN:60 BASS:38 MIDDLE:35 TREBLE:39 PRESENCE:69 VOLUME:35	LO:50 HI:68 BAL:100 VOL:-17.0	VOL:100 Min:0 Max:100 Curve:A	Time: J F.B:30 Mix:25 Tail:ON	PreD:19 Decay:3 Tone:8 Mix:24

283 : POPS LEAD

This sound, which uses REDLOOM and SweetDrv, is good for playing lead parts with guitars that have single-coil pickups.

LEVEL: 80

ZNR	SWEET DRIVE	REDLOOM	IR	PINGPONG DELAY	BRIGHT HALL
DETECT:EFXIN Depth:100 THRSH:30 Decay:0	Gain:25 Tone:55 Focus:72 VOL:58	GAIN:72 BASS:50 MIDDLE:45 TREBLE:59 PRESENCE:76 VOLUME:37	LO:49 HI:59 BAL:100 VOL:-16.0	Time: J F.B:13 Mix:26 Tail:ON	PreD:21 Decay:3 Tone:8 Mix:35

284 : POPS PAD

Using REDLOOM and BrightHall, this sound is good for playing long chords with single-coil-pickup guitars.

LEVEL: 80

ZNR	COMP	REDLOOM	IR	ANALOG CHORUS	PEDAL VOL	PINGPONG DELAY	BRIGHT HALL
DETECT:EFXIN Depth:100 THRSH:30 Decay:0	Sense:6 ATTCK:SLOW Tone:6 VOL:49	GAIN:35 BASS:46 MIDDLE:47 TREBLE:48 PRESENCE:73 VOLUME:55	LO:45 HI:60 BAL:100 VOL:-17.2	Depth:83 Rate:24 Tone:50 Mix:100	VOL:100 Min:0 Max:100 Curve:A	Time: J F.B:35 Mix:44 Tail:ON	PreD:16 Decay:30 Tone:9 Mix:53

BANK BT : FUSION

285 : Fusion CLN

This clean sound, which uses FD TWNR and Chorus, is great for fusion arpeggios and strumming.

LEVEL: 80

BLACK OPT Comp:0 Lo:50 Hi:50 VOL:28	FD TWNR GAIN:34 BASS:75 MIDDLE:77 TREBLE:48 PRESENCE:66 VOLUME:47 BRIGHT:OFF SPEED:0	IR LO:48 HI:56 BAL:100 VOL:-17.5	LMT-76 Input:35 Ratio:4:1 REL:20 Output:66	PEDAL VOL VOL:100 Min:0 Max:100 Curve:A	CHORUS Depth:40 Rate:25 Tone:6 Mix:16	DELAY Time:483 F.B:25 Mix:21 Tail:ON	BRIGHT HALL PreD:53 Decay:4 Tone:7 Mix:28
--	---	---	---	--	--	---	--

286 : Fusion DRV

This drive sound uses MATCH30 and BlackOpt and is good for fusion backing parts.

LEVEL: 80

ZNR DETCT:EFXIN Depth:60 THRS:30 Decay:0	BLACK OPT Comp:0 Lo:52 Hi:50 VOL:31	MATCH30 GAIN:100 BASS:57 MIDDLE:45 TREBLE:58 PRESENCE:63 VOLUME:38 GAIN2:OFF CUT:0	IR LO:40 HI:64 BAL:100 VOL:-19.6	PEDAL VOL VOL:100 Min:0 Max:100 Curve:A	CHORUS Depth:40 Rate:25 Tone:6 Mix:13	DELAY Time:463 F.B:25 Mix:22 Tail:ON	PLATE PreD:18 Decay:15 Mix:14 Tail:OFF
---	--	---	---	--	--	---	---

287 : FusionLEAD

The combination of POLLEX and PolyShift creates this sound that is good for single-note leads with a doubled octave below.

LEVEL: 80

ZNR DETCT:EFXIN Depth:100 THRS:28 Decay:0	POLLEX GAIN:98 BASS:13 MIDDLE:59 TREBLE:35 PRESENCE:45 VOLUME:45	IR LO:50 HI:50 BAL:100 VOL:-18.0	POLY SHIFT Shift:-12 Tone:90 Wet:37 Dry:80	PINGPONG DELAY Time:J F.B:15 Mix:20 Tail:OFF	ROOM PreD:9 Decay:30 Mix:25 Tail:OFF
--	---	---	---	---	---

288 : Fusion AMB

This ambient sound, which combines Pitch DLY with ICE Delay, is good for playing long chords.

LEVEL: 80

MATCH30 GAIN:34 BASS:65 MIDDLE:76 TREBLE:72 PRESENCE:83 VOLUME:84 GAIN2:OFF CUT:0	MS 4x12 GB MIC:ON D57:D421:0 Hi:59 Lo:34	PEDAL VOL VOL:100 Min:0 Max:100 Curve:A	PITCH DELAY Pitch:0.05 Time:468 F.B:28 Mix:31	ICE DELAY INTVL:OCT Time:J F.B:43 Mix:38	AIR Size:46 REF:4 Mix:32 Tail:OFF	CHURCH PreD:46 Decay:72 Mix:31 Tail:OFF
--	---	--	--	---	--	--

BANK BU : BLUES

289 : Blues CLN

This clean sound that is good for blues backing parts uses FD Spring with FD DLXR tremolo.

LEVEL: 80

ZNR	FD DLXR	IR	PEDAL VOL	FD SPRING	DELAY	PINGPONG DELAY	BRIGHT HALL
DETECT:EPXIN Depth:100 THRSH:30 Decay:0	GAIN:32 BASS:58 MIDDLE:51 TREBLE:58 PRESENCE:75 VOLUME:80 INPUT:NORMAL SPEED:12	LO:67 HI:60 BAL:100 VOL:-15.8	VOL:100 Min:0 Max:100 Curve:A	Color:0 Lo:89 Hi:100 Mix:22	Time:J F.B:16 Tail:ON	Time:J F.B:19 Mix:24 Tail:ON	PreD:80 Decay:1 Tone:8 Mix:22

290 : Blues DRV

This drive sound with FD DLXR is perfect for playing blues backing parts.

LEVEL: 80

ZNR	CHROME WAH	GOLD DRIVE	SPRING	FD DLXR	IR	AIR	BRIGHT HALL
DETECT:EPXIN Depth:100 THRSH:30 Decay:0	P-FREQ:50 Range:50 Dry:0 VOL:80	Gain:2 Bass:59 Treb:42 VOL:51	PreD:1 Decay:9 Mix:10 Tail:OFF	GAIN:78 BASS:63 MIDDLE:51 TREBLE:64 PRESENCE:84 VOLUME:69 INPUT:NORMAL SPEED:0	LO:53 HI:57 BAL:100 VOL:-15.1	Size:26 REF:5 Mix:53 Tail:OFF	PreD:55 Decay:1 Tone:6 Mix:20

291 : Blues LEAD

FD DLXR is boosted with TS Drive for this overdrive sound that is perfect for lead blues lines.

LEVEL: 80

ZNR	CHROME WAH	TS DRIVE	FD DLXR	IR	TAPE ECHO	AIR	BRIGHT HALL
DETECT:EPXIN Depth:100 THRSH:30 Decay:0	FREQ:50 Range:50 Dry:0 VOL:80	Gain:20 Boost:OFF Tone:62 VOL:90	GAIN:69 BASS:59 MIDDLE:40 TREBLE:61 PRESENCE:72 VOLUME:70 INPUT:NORMAL SPEED:0	LO:62 HI:61 BAL:100 VOL:-13.3	Time:384 F.B:20 Mix:20 Tail:OFF	Size:18 REF:5 Mix:55 Tail:OFF	PreD:42 Decay:10 Tone:6 Mix:24

292 : Blues FUZZ

This octave fuzz sound, which uses FD TWNR and OctFuzz, is perfect for high-fret lead playing.

LEVEL: 80

ZNR	CHROME WAH	OCT FUZZ	FD TWNR	IR	TAPE ECHO	BRIGHT HALL
DETECT:EPXIN Depth:100 THRSH:30 Decay:0	FREQ:50 Range:50 Dry:0 VOL:80	Boost:17 Color:2 Tone:48 VOL:95	GAIN:33 BASS:34 MIDDLE:44 TREBLE:39 PRESENCE:78 VOLUME:64 BRIGHT:OFF SPEED:0	LO:52 HI:60 BAL:100 VOL:-16.1	Time:384 F.B:28 Mix:28 Tail:OFF	PreD:42 Decay:10 Tone:2 Mix:35

BANK BV : PROG.M

293 : Prog.M CLN

This clean sound, which combines multiple modulations, is good for prog metal arpeggios played on guitars with humbucker pickups.

LEVEL: 80

COMP Sense:6 ATTCK:FAST Tone:8 VOL:65	STONE PHASER Color:1 Depth:60 Rate:30 RESO:0	ANALOG CHORUS Depth:60 Rate:30 Tone:50 Mix:50	HW100 GAIN:30 BASS:64 MIDDLE:16 TREBLE:72 PRESENCE:76 VOLUME:67 INPUT:BRILL	IR LO:42 HI:53 BAL:100 VOL:-15.2	STEREO CHORUS Depth:80 Rate:30 Tone:7 Mix:87	PINGPONG DELAY Time:570 F.B:17 Mix:39 Tail:OFF	PLATE PreD:30 Decay:36 Mix:16 Tail:OFF
--	---	--	---	---	---	---	---

294 : Prog.M DRV

Using POLLEX, this drive sound is good for Djent-style backing parts played with guitars that have humbucker pickups.

LEVEL: 80

ZNR DETCT:GTRIN Depth:100 THRSH:82 Decay:0	EP STOMP Gain:64 Bass:-2 Treble:0 VOL:100	POLLEX GAIN:28 BASS:63 MIDDLE:40 TREBLE:68 PRESENCE:31 VOLUME:62	IR LO:53 HI:55 BAL:100 VOL:-21.2	PEDAL VOL VOL:100 Min:0 Max:100 Curve:A	GUITAR GEQ 7 100:1.0 200:1.5 400:-0.5 800:-4.5 1.6k:2.5 3.2k:3.0 6.4k:-0.5 VOL:80	DELAY Time:380 F.B:17 Mix:36 Tail:ON
---	--	---	---	--	--	---

295 : Prog.M DBL

This doubling high-gain sound using 7 HEAVEN and GEMINOS is suitable for Djent-style riff playing with guitars that have humbucker pickups.

LEVEL: 80

NOISE GATE DETCT:EPFXIN Depth:100 THRSH:60 Decay:0	TS DRIVE Gain:0 Boost:OFF Tone:75 VOL:72	PARAMETRIC EQ FREQ:1.6K Q:16.0 Gain:6.0 VOL:80	7 HEAVEN GAIN:25 BASS:73 MIDDLE:22 TREBLE:56 PRESENCE:83 VOLUME:48	IR LO:50 HI:55 BAL:100 VOL:-16.3	PEDAL VOL VOL:100 Min:0 Max:100 Curve:A	DELAY Time:380 F.B:17 Mix:40 Tail:ON	GEMINOS Tight:50 Mode:ST-2 Wet:75 Dry:75
---	---	---	---	---	--	---	---

296 : Prog.M LD

This high-gain sound, which uses KRAMPUS and P-P Delay, is good for playing lead parts with guitars that have humbucker pickups.

LEVEL: 80

ZNR DETCT:EPFXIN Depth:100 THRSH:50 Decay:0	BLACK WAH FREQ:50 Range:50 Dry:0 VOL:80	TS DRIVE Gain:30 Boost:OFF Tone:62 VOL:94	KRAMPUS GAIN:65 BASS:29 MIDDLE:56 TREBLE:62 PRESENCE:62 VOLUME:56	IR LO:40 HI:74 BAL:100 VOL:-20.7	PINGPONG DELAY Time:J F.B:30 Mix:35 Tail:ON	BRIGHT HALL PreD:22 Decay:13 Tone:6 Mix:46
--	--	--	--	---	--	---

BANK BW : VINTAGE

297 : Rockabilly

This rockabilly sound, which combines FD B-MAN with SlapBackD, is good for galloping on guitars with single-coil pickups.

PEDAL VOL.
VOL:100
Min:0
Max:100
Curve:A

GRAY COMP
SUSTN:17
Lo:36
Hi:60
VOL:53

RC BOOST
Gain:27
Bass:48
Treble:51
VOL:45

SLAP BACK-D
Time:99
F.B:29
Mix:40
SubDv: J

FD B-MAN
GAIN:34
BASS:13
MIDDLE:69
TREBLE:46
PRESENCE:79
VOLUME:39
INPUT:BRIGHT

IR
LO:50
HI:50
BAL:100
VOL:-14.5

BRIGHT ROOM
PreD:5
Decay:10
Tone:7
Mix:60

LEVEL
80

298 : EU Boogie

Using BG MK1, this 70s style lead sound is good for guitars with humbuckers.

BLACK WAH
FREQ:50
Range:50
Dry:0
VOL:80

EP STOMP
Gain:19
Bass:-2
Treble:-3
VOL:49

BG MK1
GAIN1:62
BASS:20
MIDDLE:72
TREBLE:65
PRESENCE:67
VOLUME:58
GAIN2:67

TAPE ECHO
Time:358
F.B:27
Mix:24
Tail:OFF

IR
LO:50
HI:50
BAL:100
VOL:-21.0

PLATE
PreD:9
Decay:34
Mix:22
Tail:OFF

LEVEL
80

299 : 60's

Combining TapeEcho and FD Spring, this 60s style sound is good for single note riffs on guitars with single-coil pickups and wound strings.

ZNR
DETECT:GTRIN
Depth:73
THRS:30
Decay:0

FD SPRING
Color:1
Lo:100
Hi:100
Mix:23

FD DLXR
GAIN:42
BASS:16
MIDDLE:49
TREBLE:79
PRESENCE:68
VOLUME:100
INPUT:NORMAL
SPEED:0

IR
LO:50
HI:50
BAL:100
VOL:-14.0

PEDAL VOL.
VOL:100
Min:0
Max:100
Curve:A

TAPE ECHO
Time:99
F.B:20
Mix:66
Tail:OFF

LEVEL
80

300 : HazyFuzz

This sound, which combines OctFuzz and MS1959, is good for playing lead parts on guitars that have single-coil pickups. A unique upper octave sound can be achieved by lowering the guitar tone and playing single notes above the 12th fret position.

ZNR
DETECT:EPXIN
Depth:100
THRS:66
Decay:0

OCT FUZZ
Boost:41
Color:2
Tone:52
VOL:72

CHROME WAH
FREQ:50
Range:50
Dry:0
VOL:80

THE VIBE
Speed:25
Depth:60
Mode:CHORS
VOL:80

MS1959
GAIN:36
BASS:50
MIDDLE:70
TREBLE:60
PRESENCE:40
VOLUME:80
INPUT2:OFF

IR
LO:50
HI:50
BAL:100
VOL:-18.0

BRIGHT HALL
PreD:24
Decay:10
Tone:5
Mix:32

LEVEL
80

BANK BX : JAZZ-FUNK

301 : Jazz CLN

Using REDLOOM and LMT-76, this clean sound is good for front position jazz playing with guitars that have humbucker pickups.

LEVEL: 80

BLACK OPT Comp:13 Lo:50 Hi:50 VOL:25	REDLOOM GAIN:24 BASS:80 MIDDLE:69 TREBLE:53 PRESENCE:46 VOLUME:65	IR LO:48 HI:50 BAL:58 VOL:-20.3	GUITAR GEQ 7 100:0.0 200:0.5 400:2.5 800:2.5 1.6k:-1.5 3.2k:0.0 6.4k:2.5 VOL:80	LMT-76 Input:40 Ratio:4:1 REL:20 Output:70	PEDAL VOL VOL:100 Min:0 Curve:A	BRIGHT HALL PreD:8 Decay:8 Tone:10 Mix:33
---	--	--	--	---	---	--

302 : 70'sRhythm

Using GrayComp and Phaser, this 70s style sound is good for strumming.

LEVEL: 80

ZNR DETECT:EFXIN Depth:60 THRSH:30 Decay:0	GRAY COMP SUSTN:28 Lo:60 Hi:68 VOL:40	PHASER Color:8 STG Depth:95 Rate:7 RESO:50	FD TWINR GAIN:30 BASS:37 MIDDLE:0 TREBLE:65 PRESENCE:87 VOLUME:100 BRIGHT:OFF SPEED:0	FD 2x12 MIC:ON D57:D421:21 Hi:56 Lo:50	LMT-76 Input:25 Ratio:4:1 REL:20 Output:49	PEDAL VOL VOL:100 Min:0 Curve:A	SPRING PreD:1 Decay:20 Mix:10 Tail:OFF
---	--	---	--	---	---	---	---

303 : Sparky

Using REDLOOM and BlackOpt, this clean sound is perfect for funky strumming with guitars that have single-coil pickups.

LEVEL: 80

ZNR DETECT:EFXIN Depth:100 THRSH:30 Decay:0	BLACK OPT Comp:50 Lo:50 Hi:50 VOL:76	REDLOOM GAIN:31 BASS:27 MIDDLE:39 TREBLE:65 PRESENCE:63 VOLUME:53	IR LO:37 HI:54 BAL:69 VOL:-12.3	DELAY Time:560 F.B:17 Mix:13 Tail:OFF	BRIGHT ROOM PreD:24 Decay:18 Tone:7 Mix:30	PEDAL VOL VOL:100 Min:0 Max:100 Curve:A
--	---	--	--	--	---	--

304 : FunkyWah

This auto-wah sound that combines MS 1959 and AutoWah is perfect for funky single-note phrases.

LEVEL: 80

ZNR DETECT:EFXIN Depth:100 THRSH:30 Decay:0	AUTO WAH Mode:UP Sense:9 RESO:8 VOL:80	PHASER Color:8 STG Depth:69 Rate:12 RESO:50	MS1959 GAIN:23 BASS:33 MIDDLE:50 TREBLE:59 PRESENCE:40 VOLUME:68 INPUT2:30	IR LO:47 HI:57 BAL:100 VOL:-15.2	PINGPONG DELAY Time:J F.B:13 Mix:22 Tail:ON	ROOM PreD:17 Decay:10 Mix:46 Tail:OFF	PEDAL VOL VOL:100 Min:0 Max:100 Curve:A
--	---	--	--	---	--	--	--

BANK BY : ALT-ROCK

305 : Alt.HW

Combining NYC Muff and HW100, this sound is good for playing alternative rock backing parts.

LEVEL 80

ZNR	NYC MUFF	WAH 100	STONE PHASER	REVERSE DELAY	HW100	IR
DETCT:GTRIN Depth:100 THRSH:30 Decay:0	SUSTN:73 Tone:72 BAL:40 VOL:84	FREQ:25 Depth:40 Dry:0 VOL:80	Color:1 Depth:100 Rate:35 RESO:89	Time: J x2 F.B:20 BAL:50 Tail:OFF	GAIN:61 BASS:35 MIDDLE:76 TREBLE:72 PRESENCE:93 VOLUME:59 INPUT:BRILL	LO:50 HI:50 BAL:100 VOL:-18.0

306 : SwVibClean

Using SwellVibe, this is a clean sound with a gentle vibrato, and is good for arpeggios played with guitars that have single-coil pickups.

LEVEL 80

ZNR	HW100	HW 4x12	SWELL VIBE	STEREO CHORUS	PEDAL VOL	PINGPONG DELAY	HD HALL
DETCT:GTRIN Depth:100 THRSH:16 Decay:50	GAIN:39 BASS:31 MIDDLE:24 TREBLE:68 PRESENCE:65 VOLUME:37 INPUT:BRILL	MIC:ON D57:D421:50 Hi:50 Lo:47	Depth:49 Speed:51 Rise:47 Vol:80	Depth:75 Rate:25 Tone:7 Mix:55	VOL:100 Min:0 Max:100 Curve:A	Time:480 F.B:30 Mix:49 Tail:ON	PreD:81 Decay:45 Mix:62 Tail:OFF

307 : DC.Crunch

This bright crunch sound uses MATCH30 and is good for backing play.

LEVEL 80

ZNR	BLACK OPT	TS DRIVE	MATCH30	IR	DELAY	BRIGHT HALL	PEDAL VOL
DETCT:EPFIN Depth:100 THRSH:59 Decay:0	Comp:50 Lo:50 Hi:50 VOL:76	Gain:67 Boost:OFF Tone:50 VOL:75	GAIN:46 BASS:56 MIDDLE:43 TREBLE:41 PRESENCE:56 VOLUME:95 GAIN2:OFF CUT:0	LO:50 HI:50 BAL:100 VOL:-16.7	Time: J F.B:18 Mix:25 Tail:OFF	PreD:100 Decay:10 Tone:7 Mix:24	VOL:100 Min:0 Max:100 Curve:A

308 : MudFuzz

This fuzz sound, which combines MUDDY and NYC Muff, is good for playing single-note riffs on guitars with single-coil pickups.

LEVEL 80

ZNR	BLACK WAH	OUTPUT BOOST	NYC MUFF	MUDDY	IR	SPRING
DETCT:EPFIN Depth:100 THRSH:30 Decay:0	FREQ:50 Range:50 Dry:0 VOL:80	Range:3 Boost:60 Tone:50 VOL:90	SUSTN:24 Tone:62 BAL:31 VOL:92	GAIN:30 BASS:38 MIDDLE:69 TREBLE:57 PRESENCE:62 VOLUME:50	LO:45 HI:58 BAL:100 VOL:-17.2	PreD:20 Decay:18 Mix:20 Tail:OFF

BANK BZ : AMBIENT

309 : AMB PAD

Multiple reverb effects are combined in this pad sound with massive reverberations that is good for playing long chords.

LEVEL: 80

BLACK OPT Comp:50 Lo:50 Hi:53 VOL:76	IR LO:51 Hi:66 BAL:100 VOL:-15.3	SLOW ATTACK DELAY Swell:9 Time:J F.B:71 Mix:64	PARTICLE-R Mode:STBL Decay:75 Mix:60 Tail:OFF	BRIGHT HALL PreD:100 Decay:30 Tone:9 Mix:63	PEDAL VOL. VOL:100 Min:0 Max:100 Curve:A
---	---	---	--	--	---

310 : MoonSnow

The combination of PolyShift and ReverseDL create this mystical sound that is good for playing long chords.

LEVEL: 80

ZNR DETECT:EFXIN Depth:60 THRSH:30 Decay:0	POLY SHIFT Shift:12 Tone:48 Wet:73 Dry:70	FD TWINR GAIN:61 BASS:74 MIDDLE:50 TREBLE:36 PRESENCE:34 VOLUME:69 BRIGHT:OFF SPEED:0	REVERSE DELAY Time:1000 F.B:14 BAL:31 Tail:ON	IR LO:81 Hi:55 BAL:100 VOL:-10.0	PEDAL REVERB InLvl:100 PreD:49 Decay:24 Mix:90
---	--	--	--	---	---

311 : Sequencer

This sequenced filter sound, which combines SeqFLTR with Razor DRV, is good for playing long chords.

LEVEL: 50

RAZOR DRIVE Gain:33 Edge:93 Lo:39 VOL:15	VELVET GAIN:63 BASS:65 MIDDLE:50 TREBLE:38 PRESENCE:50 VOLUME:55	SEQ FILTER Step:8 PTTRN:7 Speed:28 RESO:6	RED 4x10 MIC:OFF D57:D421:50 Hi:54 Lo:50	NOISE GATE DETECT:EFXIN Depth:100 THRSH:85 Decay:0	HD HALL PreD:29 Decay:21 Mix:29 Tail:OFF	PEDAL VOL. VOL:100 Min:0 Max:100 Curve:A
---	---	--	---	---	---	---

312 : Polyor

This synth-like sound that is good for arpeggios combines PolyShift and AutoPan.

LEVEL: 80

COMP Sense:6 ATTCK:FAST Tone:6 VOL:80	MS450s GAIN:16 BASS:30 MIDDLE:70 TREBLE:36 PRESENCE:30 VOLUME:60 INPUT2:OFF	POLY SHIFT Shift:12 Tone:90 Wet:80 Dry:80	MS 4x12 AL MIC:OFF D57:D421:50 Hi:50 Lo:50	PEDAL VOL. VOL:100 Min:0 Max:100 Curve:B	AUTO PAN Rate:20 Width:30 Clip:0 VOL:100	TAPE ECHO Time:560 F.B:64 Mix:56 Tail:ON	CHURCH PreD:96 Decay:49 Mix:51 Tail:ON
--	---	--	---	---	---	---	---

BANK CA : COMBO AMPS

313 : Red Hot

This modern blues sound uses REDLOOM and blends a simple tone with the rich harmonics of a compact 60s tube amp.

LEVEL: 80

ZNR	RC BOOST	REDLOOM	IR	SLAP BACK-D	PEDAL VOL.	HALL
DETCT:EPXIN Depth:60 THRSH:25 Decay:0	Gain:48 Bass:48 Treble:52 VOL:48	GAIN:70 BASS:52 MIDDLE:42 TREBLE:61 PRESENCE:53 VOLUME:49	LO:35 HI:62 BAL:100 VOL:-16.0	Time:188 F.B:29 Mix:11 SubDv:J	VOL:100 Min:0 Max:100 Curve:A	PreD:70 Decay:8 Mix:24 Tail:ON

314 : UK Combo

Using UK 30A, this British combo amp sound is good for backing play with guitars that have single-coil pickups.

LEVEL: 80

ZNR	TS DRIVE	TAPE ECHO	UK30A	IR	LMT-76	ROOM	PEDAL VOL.
DETCT:EPXIN Depth:70 THRSH:30 Decay:0	Gain:15 Boost:OFF Tone:88 VOL:82	Time:600 F.B:10 Mix:11 Tail:OFF	GAIN:42 BASS:30 MIDDLE:50 TREBLE:52 PRESENCE:59 VOLUME:49 CUT:56 SPEED:0	LO:47 HI:52 BAL:100 VOL:-21.6	Input:31 Ratio:4:1 REL:20 Output:38	PreD:3 Decay:13 Mix:36 Tail:OFF	VOL:100 Min:0 Max:100 Curve:A

315 : NYC Blue

This combo amp sound, which uses WaveSHPR and FD TWNR, is good for New York blues.

LEVEL: 88

ZNR	PEDAL VOL.	COMP	WAVE SHAPER	FD TWNR	MS 4x12 AL	SLAP BACK-D	ROOM
DETCT:EPXIN Depth:60 THRSH:30 Decay:0	VOL:100 Min:0 Max:100 Curve:A	Sense:4 ATTCK:SLOW Tone:4 VOL:80	Gain:16 BASS:46 MIDDLE:49 TREBLE:42 PRESENCE:50 VOLUME:100 BRIGHT:OFF SPEED:0	GAIN:39 BASS:46 MIDDLE:49 TREBLE:42 PRESENCE:50 VOLUME:100 BRIGHT:OFF SPEED:0	MIC:ON D57:D421:72 Hi:40 Lo:50	Time:99 F.B:30 Mix:23 SubDv:J	PreD:5 Decay:15 Mix:55 Tail:OFF

316 : TXS Blues

This Texas blues sound, which uses FD DLXR and Spring, is good for guitars with single-coil pickups.

LEVEL: 80

ZNR	RC BOOST	FD DLXR	FDDX 1x12	PEDAL VOL.	DELAY	SPRING
DETCT:EPXIN Depth:70 THRSH:30 Decay:0	Gain:26 Bass:5 Treble:59 VOL:57	GAIN:86 BASS:37 MIDDLE:64 TREBLE:82 PRESENCE:62 VOLUME:86 INPUT:NORMAL SPEED:0	MIC:ON D57:D421:50 Hi:55 Lo:50	VOL:100 Min:0 Max:100 Curve:A	Time:92 F.B:17 Mix:25 Tail:OFF	PreD:1 Decay:20 Mix:14 Tail:OFF

BANK CB : STACK AMPS

317 : PunchLine

This drive sound with FD MASTER is good for backing play using the bridge humbucker.

LEVEL: 80

ZNR	BLACK WAH	TREMOLO	FD MASTER	IR	PHASER	DELAY	AIR
DETCT:GTRIN Depth:100 THRSH:36 Decay:0	FREQ:50 Range:50 Dry:0 VOL:80	Wave:TUBE Depth:99 Rate: VOL:60	GAIN:63 BASS:58 MIDDLE:51 TREBLE:68 PRESENCE:77 VOLUME:57 FAT:ON	LO:63 Hi:55 BAL:100 VOL:-18.0	Color:8 STG Depth:76 Rate:4 RESO:25	Time:J F.B:10 Mix:24 Tail:OFF	Size:28 REF:5 Mix:41 Tail:OFF

318 : PLX-DST

This progressive metal sound with a mid scoop uses POLLEX and is good for single-note backing using guitars with humbucker pickups.

LEVEL: 80

ZNR	EP STOMP	POLLEX	IR	GUITAR GEQ 7	DELAY	PEDAL VOL
DETCT:GTRIN Depth:100 THRSH:82 Decay:0	Gain:64 Bass:-2 Treble:0 VOL:100	GAIN:28 BASS:46 MIDDLE:41 TREBLE:67 PRESENCE:64 VOLUME:47	LO:50 HI:54 BAL:76 VOL:-18.0	100:0.0 200:0.0 400:-0.5 800:-4.5 1.6k:2.5 3.2k:1.0 6.4k:0.0 VOL:80	Time:380 F.B:17 Mix:40 Tail:ON	VOL:100 Min:0 Max:100 Curve:A

319 : ExtraLD

This drive sound, which uses XtasyBlue and GoldDrive, is good for playing lead parts with guitars that have humbucker pickups.

LEVEL: 80

ZNR	BLACK WAH	GOLD DRIVE	XTACY BL	IR	SOFT ECHO
DETCT:EFXIN Depth:100 THRSH:17 Decay:0	FREQ:40 Range:50 Dry:0 VOL:81	Gain:14 Bass:35 Treble:44 VOL:56	GAIN:60 BASS:70 MIDDLE:55 TREBLE:60 PRESENCE:66 VOLUME:61 STRCT:HI	LO:50 HI:50 BAL:82 VOL:-13.7	MOD:ON Time:386 F.B:31 Mix:31

320 : ThickRiff

This high-gain sound, which uses KRAMPUS and MetalWRLD, is perfect for metal riffs played with guitars that have humbucker pickups.

LEVEL: 80

METAL WORLD	LMT-76	GUITAR GEQ	ZNR	KRAMPUS	IR	PEDAL VOL
Gain:21 Bass:56 Treble:57 VOL:81	Input:40 Ratio:4:1 REL:20 Output:35	160:3.0 400:1.5 800:-1.0 3.2k:3.0 6.4k:3.0 12k:2.5 VOL:85 CH SEL:LATCH	DETCT:GTRIN Depth:100 THRSH:68 Decay:0	GAIN:82 BASS:66 MIDDLE:37 TREBLE:66 PRESENCE:68 VOLUME:56	LO:50 HI:50 BAL:100 VOL:-19.3	VOL:100 Min:0 Max:100 Curve:A

BANK CC : DELAY

321 : PulseDelay

This filtered delay sound, which is good with single-coil pickups, uses REDLOOM and FilterDly to synchronize the effect to dotted eighth notes with the master tempo BPM setting.

BLACK WAH
 P-FREQ:50
 Range:50
 Dry:0
 VOL:80

BLACK OPT
 Comp:36
 Lo:50
 Hi:50
 VOL:80

REDLOOM
 GAIN:27
 BASS:42
 MIDDLE:23
 TREBLE:62
 PRESENCE:69
 VOLUME:61

RED 4x10
 MIC:ON
 D57:D421:7C
 Hi:65
 Lo:50

SUPER CHORUS
 Depth:47
 Rate:50
 Tone:50
 Mix:41

FILTER DELAY
 Time:♪
 F.B:60
 Mix:70
 Tail:ON

HD HALL
 PreD:29
 Decay:40
 Mix:30
 Tail:ON

LEVEL: 80

322 : HW Dotted

This modulated delay sound uses HW 100 and ModDelay to synchronize the delay to dotted eighth notes with the master tempo BPM setting.

BLACK OPT
 Comp:50
 Lo:50
 Hi:50
 VOL:76

HW100
 GAIN:36
 BASS:31
 MIDDLE:69
 TREBLE:66
 PRESENCE:68
 VOLUME:60
 INPUT:BRILL

IR
 LO:71
 HI:55
 BAL:100
 VOL:-16.7

PEDAL VOL.
 VOL:100
 Min:0
 Max:100
 Curve:A

MOD DELAY
 Time:♪
 F.B:24
 Mix:48
 Tail:OFF

HD HALL
 PreD:18
 Decay:27
 Mix:22
 Tail:OFF

LEVEL: 80

323 : Andromeda

This ambient sound, which uses REDLOOM and ReverseDL, is good for playing long chords.

LMT-76
 Input:30
 Ratio:4:1
 REL:20
 Output:55

CHORUS
 Depth:12
 Rate:16
 Tone:1
 Mix:24

REVERSE DELAY
 Time:1000
 F.B:20
 BAL:50
 Tail:OFF

REDLOOM
 GAIN:32
 BASS:44
 MIDDLE:56
 TREBLE:67
 PRESENCE:55
 VOLUME:72

IR
 LO:50
 HI:50
 BAL:58
 VOL:-17.6

BRIGHT HALL
 PreD:49
 Decay:10
 Tone:5
 Mix:46

PEDAL VOL.
 VOL:100
 Min:0
 Max:100
 Curve:A

LEVEL: 80

324 : 1959Crunch

This crunch sound with MS 1959 and TapeEcho is good for backing play using the bridge humbucker.

PEDAL VOL.
 VOL:100
 Min:20
 Max:100
 Curve:A

ZNR
 DETCT:EFXIN
 Depth:20
 THRSH:30
 Decay:0

COMP
 Sense:3
 ATTCK:SLOW
 Tone:5
 VOL:60

MS1959
 GAIN:24
 BASS:60
 MIDDLE:62
 TREBLE:45
 PRESENCE:49
 VOLUME:63
 INPUT2:24

IR
 LO:50
 HI:57
 BAL:79
 VOL:-15.5

TAPE ECHO
 Time:560
 F.B:34
 Mix:41
 Tail:ON

ROOM
 PreD:52
 Decay:13
 Mix:26
 Tail:OFF

LEVEL: 80

BANK CD : SWAY

325 : Swellvibe

This modulation sound, which combines MUDDY and SwellVibe, is good for arpeggios.

Depth:42
Speed:61
Rise:40
Vol:80

GAIN:39
BASS:31
MIDDLE:40
TREBLE:49
PRESENCE:79
VOLUME:36

LO:50
HI:50
BAL:100
VOL:-18.8

Input:22
Ratio:4:1
REL:39
Output:46

VOL:100
Min:0
Max:100
Curve:A

Time:360
F.B:27
Mix:49
Tail:OFF

PreD:1
Decay:23
Tone:8
Mix:26

LEVEL
80

326 : ArpMachine

This Rotary sound, which uses PDL Roto and REDLOOM, is good for arpeggios.

DETECT:EFXIN
Depth:65
THRSH:30
Decay:0

Mode:FAST
Drive:28
BAL:45
VOL:80

GAIN:45
BASS:39
MIDDLE:37
TREBLE:68
PRESENCE:40
VOLUME:75

THRSH:29
Ratio:6
ATTCK:6
VOL:72

Time:560
F.B:17
Mix:13
Tail:OFF

PreD:29
Decay:21
Mix:29
Tail:OFF

LEVEL
80

327 : UK Clean

Combining Phaser and ParticleR with UK30A, this is an effective clean sound that is good for arpeggios.

GAIN:15
BASS:46
MIDDLE:30
TREBLE:60
PRESENCE:60
VOLUME:40
CUT:78
SPEED:0

Comp:30
Lo:50
Hi:60
VOL:72

Color:8 STG
Depth:100
Rate:12
RESO:17

MIC:ON
D57-D421:50
Hi:79
Lo:51

VOL:100
Min:0
Max:100
Curve:A

Time:J
F.B:30
Mix:44
Tail:ON

Mode:STBL
Decay:39
Tail:ON

PreD:1
Decay:30
Tone:10
Mix:63

LEVEL
100

328 : StayWavy

This sound with FD Spring and Tremolo is good for backing parts in pop songs and rock ballads.

DETECT:EFXIN
Depth:65
THRSH:30
Decay:0

VOL:100
Min:0
Max:100
Curve:A

Gain:25
Bass:-1
Treb:1
VOL:53

Wave:TRI
Depth:65
Rate:50
VOL:70

GAIN:39
BASS:41
MIDDLE:44
TREBLE:50
PRESENCE:56
VOLUME:36
INPUT:BRILL

LO:59
HI:63
BAL:100
VOL:-17.5

Color:0
Lo:100
Hi:99
Mix:30

LEVEL
80

BANK CE : VERSATILE

329 : Gig800

This crunch sound, which uses MS800, is good for rock backing parts.

LEVEL 80

BLACK WAH	TS DRIVE	MS800	IR	DELAY	BRIGHT HALL
FREQ:50 Range:50 Dry:0 VOL:80	Gain:0 Boost:OFF Tone:54 VOL:98	GAIN:76 BASS:53 MIDDLE:58 TREBLE:47 PRESENCE:39 VOLUME:70 INPUT:HI	LO:52 MI:50 BAL:100 VOL:-16.9	Time:373 F.B:13 Mix:25 Tail:OFF	PreD:58 Decay:10 Tone:5 Mix:34

330 : 45 Clean

This clear clean sound, which uses MS 45os, is great for backing parts.

LEVEL 80

ZNR	RC BOOST	MS45os	IR	PEDAL VOL	PINGPONG DELAY	DELAY	CHAMBER
DETECT:EFXIN Depth:100 THRSH:30 Decay:0	Gain:20 Bass:48 Treb:50 VOL:48	GAIN:29 BASS:50 MIDDLE:70 TREBLE:58 PRESENCE:42 VOLUME:78 INPUT2:OFF	LO:50 HI:58 BAL:100 VOL:-16	VOL:100 Min:0 Max:100 Curve:A	Time:J F.B:30 Mix:30 Tail:OFF	Time:J F.B:40 Mix:60 Tail:ON	PreD:52 Decay:40 Mix:30 Tail:ON

331 : R&B Clean

This clean sound that uses FD TWNR is perfect for R&B backing parts.

LEVEL 80

PEDAL VOL	COMP	FD TWNR	IR	ANALOG CHORUS	DELAY	SPRING
VOL:100 Min:1 Max:100 Curve:B	Sense:6 ATTCK:FAST Tone:2 VOL:80	GAIN:40 BASS:52 MIDDLE:51 TREBLE:68 PRESENCE:64 VOLUME:60 BRIGHT:OFF SPEED:0	LO:50 HI:50 BAL:100 VOL:-7.9	Depth:52 Rate:54 Tone:49 Mix:82	Time:560 F.B:21 Mix:27 Tail:OFF	PreD:1 Decay:14 Mix:30 Tail:OFF

332 : FD Clean

This simple clean sound uses FD TWNR and is good for backing play.

LEVEL 80

CHROME WAH	OPT COMP	FD TWNR	IR	LMT-76	ROOM
FREQ:50 Range:50 Dry:0 VOL:80	Drive:5 Lo:50 Hi:50 VOL:60	GAIN:30 BASS:42 MIDDLE:44 TREBLE:39 PRESENCE:50 VOLUME:90 BRIGHT:OFF SPEED:0	LO:50 HI:50 BAL:100 VOL:-13.7	Input:29 Ratio:4:1 REL:20 Output:44	PreD:5 Decay:10 Mix:38 Tail:OFF

BANK CF : HEAVY EFX

333 : Endorphin

Using Razor DRV, this extreme out-of-phase sound is good for single-note lead play.

LEVEL 80

NOISE GATE	AUTO WAH	RAZOR DRIVE	FD B-MAN	IR	PITCH SHIFT	VINTAGE FLANGER	ROOM
DETECT:EFXIN Depth:100 THRSH:54 Decay:0	Mode:UP Sense:7 RESO:6 VOL:80	Gain:71 Edge:17 Lo:0 VOL:39	GAIN:27 BASS:62 MIDDLE:49 TREBLE:38 PRESENCE:57 VOLUME:63 INPUT:BRIGHT	LO:60 HI:61 BAL:100 VOL:-19	Shift:-12 Fine:0 Tone:10 BAL:20	PreD:4 Depth:62 Rate:3 RESO:3	PreD:1 Decay:10 Mix:60 Tail:OFF

334 : OctDown

This drive sound, which uses KRAMPUS with PolyShift to add an octave down, is good for single-note lead play.

LEVEL 80

ZNR	KRAMPUS	IR	POLY SHIFT	BRIGHT HALL	PEDAL VOL.
DETECT:EFXIN Depth:100 THRSH:30 Decay:0	GAIN:50 BASS:50 MIDDLE:50 TREBLE:56 PRESENCE:40 VOLUME:50	LO:39 HI:66 BAL:100 VOL:-19	Shift:-12 Tone:58 Wet:67 Dry:79	PreD:1 Decay:16 Tone:7 Mix:24	VOL:100 Min:0 Max:100 Curve:A

335 : FuzzyTail

This fuzz sound uses WaveSHPR and is useful for distinctive single-note lead play.

LEVEL 80

ZNR	WAVE SHAPER	FD B-MAN	IR	PEDAL VOL.	FILTER DELAY	BRIGHT HALL
DETECT:GTRIN Depth:100 THRSH:40 Decay:0	Gain:26 Shape:87 Comp:37 VOL:70	GAIN:20 BASS:27 MIDDLE:65 TREBLE:59 PRESENCE:45 VOLUME:50 INPUT:BRIGHT	LO:50 HI:59 BAL:67 VOL:-17.1	VOL:100 Min:0 Max:100 Curve:A	Time:563 F.B:40 Tail:OFF	PreD:49 Decay:10 Tone:5 Mix:46

336 : DarkMatter

This psychedelic fuzz sounds combines WaveSHPR and SlowATTCK.

LEVEL 60

ZNR	SLOW ATTACK	AUTO WAH	WAVE SHAPER	RED 4x10	WARP PHASER	TAPE ECHO	PEDAL VOL.	CHURCH
DETECT:EFXIN Depth:100 Curve:10 THRSH:30 Decay:0	Time:21 Sense:8 Shape:21 Tone:100 VOL:80	Mode:UP Sense:8 RESO:8 VOL:80	Gain:51 Shape:21 Comp:27 VOL:83	MIC:OFF DS7-D421:50 Hi:44 Lo:50	Mode:BACK Speed:17 RESO:7 VOL:44	Time:560 F.B:64 Mix:56 Tail:ON	VOL:100 Min:0 Max:100 Curve:B	PreD:96 Decay:43 Mix:35 Tail:ON

BANK CG : MAGICAL

337 : ICE Clean

ICE Delay and ParticleR are used in this magical clean sound.

LEVEL 90

ZNR	COMP	HW100	HW 4x12	PEDAL VOL.	CLONE CHORUS	ICE DELAY	PARTICLE-R
DETECT:EPXIN Depth:100 THRSH:30 Decay:0	Sense:6 ATTCK:SLOW Tone:5 VOL:74	GAIN:22 BASS:32 MIDDLE:24 TREBLE:75 PRESENCE:77 VOLUME:92 INPUT:BRILL	MIC:OFF D57:D421:50 Hi:52 Lo:35	VOL:100 Min:0 Max:100 Curve:A	Depth:2 Rate:0 Tone:99 Mix:64	INTVL:OCT Time:J. F.B:45 Mix:45	Mode:STBL Decay:11 Mix:62 Tail:ON

338 : SciFiSyn

This synth-like sound combines RingMod and SlwAtkDly.

LEVEL 80

PEDAL VOL.	HOT SPICE	RING MODULATOR	UK30A	CORONA TRI	SLOW ATTACK DELAY	ORG 4x12	BRIGHT HALL
VOL:100 Min:0 Max:100 Curve:A	Bend:11 Buzz:57 +1oct:36 VOL:80	FREQ:40 Tone:2 BAL:50 VOL:88	GAIN:33 BASS:63 MIDDLE:54 TREBLE:34 PRESENCE:33 VOLUME:45 CUT:78 SPEED:0	Depth:100 Speed:25 Tone:100 Mix:86	Swell:31 Time:490 F.B:75 Mix:64	MIC:ON D57:D421:50 Hi:32 Lo:71	PreD:54 Decay:29 Tone:7 Mix:51

339 : Memories

This gorgeous acoustic sound combines PolyShift and Aco.Sim.

LEVEL 80

ZNR	Aco Sim.	POLY SHIFT	PEDAL VOL.	CHURCH	FD TWINR	BGN 4x12
DETECT:EPXIN Depth:100 THRSH:30 Decay:0	Top:80 Body:50 +1oct:100 VOL:80	Shift:12 Tone:90 Wets:42 Dry:80	VOL:100 Min:0 Max:100 Curve:B	PreD:0 Decay:41 Mix:54 Tail:ON	GAIN:33 BASS:42 MIDDLE:44 TREBLE:39 PRESENCE:50 VOLUME:51 BRIGHT:OFF SPEED:0	MIC:OFF D57:D421:50 Hi:50 Lo:50

340 : BOMBER!!!

Combining Bomber and ICE Delay, this sounds like an amplified explosion.

LEVEL 80

BOMBER	MATCH30	IR	PITCH DELAY	ICE DELAY	BRIGHT HALL	PEDAL VOL.
Decay:50 Tone:4 Mix:30 ON/OFF:TRGR	GAIN:33 BASS:46 MIDDLE:49 TREBLE:61 PRESENCE:52 VOLUME:73 GAIN:OFF CUT:0	LO:38 HI:56 BAL:100 VOL:-18.6	Pitch:-0.05 Time:90 F.B:80 Mix:80	INTVL:OCT Time:J. F.B:62 Mix:76	PreD:8 Decay:8 Tone:9 Mix:42	VOL:100 Min:0 Max:100 Curve:A

341-440 : NEW BASS PRESET PATCH MEMORY (for PA System)

Preset patch memories 341–440 optimize tones for use connected to PA systems.

Use these when connecting the G11 to a PA system, powered monitor speakers or headphones.

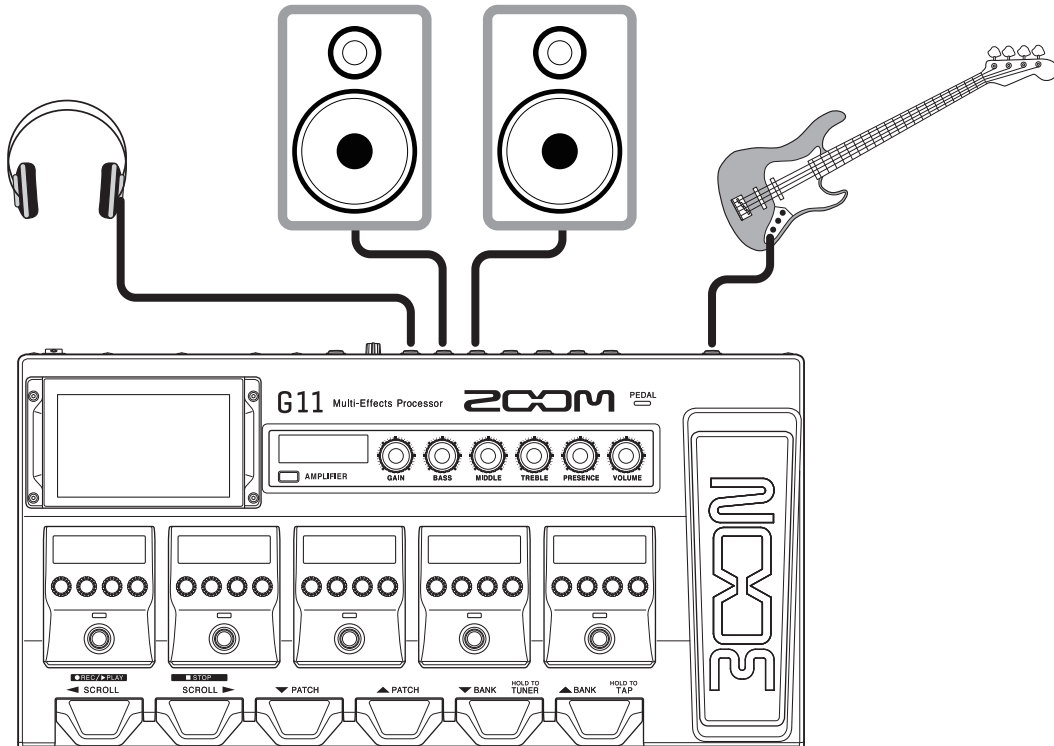

To use this preset patch memory when connected to a bass amp, turn off both the CABINET ( or  icon) and IR  .

Then adjust the EQ of the bass amp as desired.

If the bass input has a lot of noise, use noise reduction  and/or noise gate  .

BANK CH : BassAmps 1

341 : SVT Drive

This all-around rock sound combines the impulse responses of an AMPG SVT with an 8x10" cabinet.

Gain:40
Bass:F:220
Bass:10
TRBL-F:16K
Treble:34
VOL:67
MID-F:1.6K
MID:0

GAIN:36
BASS:66
MIDDLE:30
TREBLE:50
PRESENCE:0
VOLUME:76
MID-F:250
ULTRA:HI

LO:50
HI:50
BAL:100
VOL:-18.0

LEVEL
40

342 : Fat B-MAN

This heavy and warm tube amp sound combines BMAN100 with FD-B4x12.

Gain:36
Bass:0
Treble:-4
VOL:40

GAIN:53
BASS:47
MIDDLE:50
TREBLE:63
PRESENCE:0
VOLUME:43
MID-F:220
DEEP:OFF

DYN20:65
DYN57:50
Bottom:55
BAL:100

LEVEL
73

343 : SVT Clean

This clean sound combines AMPG SVT and a half-stack cabinet with a tweeter.

Comp:30
Lo:50
Hi:50
VOL:68

GAIN:24
BASS:51
MIDDLE:55
TREBLE:63
PRESENCE:0
VOLUME:80
MID-F:200
ULTRA:HI

LO:52
HI:42
BAL:80
VOL:-18.0

LEVEL
100

344 : Natural AG

This natural and powerful clean sound combines AG750 and AG4x10TW.

Gain:40
LoType:SHELF
LoFREQ:120
Lo:-15
HiFREQ:3.5K
Hi:-6
VOL:85
HMNCS:47

GAIN:35
BASS:53
MIDDLE:48
TREBLE:50
PRESENCE:0
VOLUME:76
DEEP:OFF
BRIGHT:ON

DYN20:56
DYN57:48
Bottom:50
BAL:100

LEVEL
100

BANK CI : BassAmps 2

345 : SMR Slap

Combining SMR400 and a half-stack cabinet with a tweeter, this clean sound is good for slapping.

160 COMP

THRS:-15
Ratio:4.0
Knee:HARD
VOL:62

SMR 400

GAIN:65
BASS:75
MIDDLE:63
TREBLE:50
PRESENCE:0
VOLUME:43
MID-F:800
ENHANCE:0

SMR 4x10 TW

DYN20:50
DYN57:72
Bottom:65
BAL:90

LEVEL 100

346 : Warm AC370

This warm sound combines AC370 with a uniquely-constructed cabinet that has just a single 18" speaker.

SPLITTER

FREQ:200
Lo:26
Hi:46
VOL:70

AC 370

GAIN:14
BASS:55
MIDDLE:45
TREBLE:74
PRESENCE:0
VOLUME:45
MID-F:350
BRIGHT:OFF

IR

LO:65
HI:75
BAL:65
VOL:-5.5

LEVEL 100

347 : Sunny DRV

Combining SUN CB and SN2x15, this powerful drive sound is good for 70s and 80s rock styles.

LMT-76

Input:40
Ratio:4.1
REL:20
Output:30

BA FZ SMILE

Gain:32
Tone:50
BAL:79
VOL:35

SUN CB

GAIN:70
BASS:50
MIDDLE:50
TREBLE:60
PRESENCE:0
VOLUME:40
INPUT:NORMAL
COLOR:OFF

SN 2x15

DYN20:65
DYN57:70
Bottom:50
BAL:100

LEVEL 115

348 : EBH Slap

Combining EBH360 and a half-stack cabinet with a tweeter, this bright sound is good for slapping.

MB COMP

Comp:60
LoTHR:67
HiTHR:25
VOL:33

EBH 360

GAIN:15
BASS:65
MIDDLE:58
TREBLE:50
PRESENCE:22
VOLUME:65
MID-F:2.0K
CHARA:OFF

EB 4x10 TW

DYN20:52
DYN57:42
Bottom:55
BAL:50

LEVEL 100

BANK CJ : BassAmps 3

349 : Mark Tone

This combo amp sound with a distinctive mid range combines Mini MarkB and MkB2x8TW.

Gain:50
Bass-F:55
Bass:10
TRBL-F:10K
Treble:0
VOL:60
MID-F:1.6K
MID:21

GAIN:62
BASS:50
MIDDLE:45
TREBLE:51
PRESENCE:0
VOLUME:61

DYN20:51
DYN57:83
Bottom:50
BAL:100

LEVEL
92

350 : Classic TE

Combining TE400SX and TE4x10, this clean sound is good for playing rock and fusion.

Comp:70
LoTHR:50
HiTHR:50
VOL:25

GAIN:57
BASS:52
MIDDLE:55
TREBLE:68
PRESENCE:0
VOLUME:50
STYLE-FINGER
SHAPE:2

DYN20:50
DYN57:50
Bottom:50
BAL:49

LEVEL
80

351 : Flip Tone

This vintage tube sound, which is good for soul and Motown styles, combines FlipTop and AM1x15.

Gain:40
Nature:45
Blend:61
VOL:36

GAIN:35
BASS:71
MIDDLE:64
TREBLE:60
PRESENCE:0
VOLUME:70
BRIGHT:OFF
ULTRA:OFF

DYN20:40
DYN57:70
Bottom:55
BAL:71

Input:28
Ratio:4:1
REL:31
Output:39

LEVEL
69

352 : Poly Combo

This combo amp sound, which is good for jazz, combines the impulse response of a room mic with Monotone.

OCT1:30
OCT2:0
MOD:0
Dry:86

GAIN:50
BASS:40
MIDDLE:68
TREBLE:35
PRESENCE:0
VOLUME:50
MODE:NORMAL

LO:50
HI:50
BAL:100
VOL:-17.6

LEVEL
75

BANK CK : LEGENDS

353 : Portrait

This sound is inspired by a fusion bassist famous for playing fretless bass and using harmonics.

Gain:39
FLTR:31
VOL:67
DryMx:60

Depth:85
Speed:40
Tone:40
Mix:76

GAIN:50
BASS:53
MIDDLE:73
TREBLE:50
PRESENCE:21
VOLUME:49
MODE:NORMAL

DYN20:45
DYN57:48
Bottom:50
BAL:34

LEVEL
83

354 : Liverpool

This sound is inspired by a legendary rock band formed in Liverpool in the 60s.

Gain:50
Bass-F:55
Bass:-10
TRBL-F:10K
Treble:-1
VOL:60
MID-F:700
MID:3

GAIN:62
BASS:50
MIDDLE:60
TREBLE:50
PRESENCE:0
VOLUME:37

LO:50
HI:50
BAL:80
VOL:-6.9

LEVEL
74

355 : GZR Wah

This dark and powerful wah sound is inspired by the bassist of an English band that was a driving force at the dawn of heavy metal.

GAIN:10
BASS:65
MIDDLE:44
TREBLE:53
PRESENCE:0
VOLUME:40
INPUT:NORMAL
COLOR:OFF

DYN20:50
DYN57:50
Bottom:60
BAL:100

Gain:18
FLTR:62
VOL:59
DryMx:85

Sense:4
RESO:2
Dry:50
VOL:80

LEVEL
88

356 : LarryJet

This jet phase sound is inspired by the funk bassist who is said to have created slap playing.

Mode:4
Rate:31
RESO:2
VOL:100

GAIN:49
BASS:50
MIDDLE:42
TREBLE:86
PRESENCE:0
VOLUME:67
DEEP:OFF
BRIGHT:ON

LO:44
HI:60
BAL:80
VOL:-12.7

LEVEL
48

BANK CL : JAZZ&FUNK

357 : MM Clean

This clean slap sound is inspired by a New York fusion bassist.

LMT-76
 Input:28
 Ratio:4:1
 REL:15
 Output:42

POLY SHIFT
 Shift:-12
 Tone:90
 Wet:55
 Dry:80

EXCITER
 Bass:15
 Treble:0
 VOL:78
 ON/OFF:LATCH

BASS STEREO CHORUS
 Depth:24
 Rate:14
 LoCut:280
 Mix:23

BASS GEQ
 50:0.0
 120:2.0
 400:-2.5
 500:-1.0
 800:3.5
 4.5k:3.0
 10k:4.0
 VOL:80

LEVEL: 88

358 : ModernJazz

This modern jazz fusion sound features a heavy midrange.

DYN COMP
 Sense:5
 ATTACK:SLOW
 Tone:59
 VOL:60

PRE 1073
 Gain:50
 Bass-F:220
 Bass:16
 TRBL-F:10K
 Treble:-21
 VOL:49
 MID-F:700
 MID:23

BASS ANALOG OCTAVE
 OCT1:65
 OCT2:8
 MOD:25
 Dry:86

BASS STEREO CHORUS
 Depth:75
 Rate:27
 LoCut:180
 Mix:76

BRIGHT HALL
 PreD:70
 Decay:11
 Tone:4
 Mix:18

LEVEL: 100

359 : BootFunk

This auto-wah sound is inspired by a funk bassist known for his star-shaped sunglasses and bass guitar.

BASS OCT FLUZZ
 Boost:26
 Tone:55
 Fuzz:15
 Dry:85

BASS A-WAH
 Sense:1
 RESO:6
 Dry:70
 VOL:65

AMPG SVT
 GAIN:24
 BASS:55
 MIDDLE:53
 TREBLE:73
 PRESENCE:0
 VOLUME:55
 MID-F:630
 ULTRA:OFF

FD-B 4x12
 DYN20:60
 DYN57:55
 Bottom:65
 BAL:100

LEVEL: 65

360 : Wonderful

The left-hand keyboard playing of an American singer-songwriter famous worldwide is the inspiration for this funky synthesizer sound.

Z-SYNTH
 FREQ:5
 Range:8
 Decay:72
 RESO:6
 Wave:SAW
 Tone:7
 BAL:80
 VOL:80

BASS OCTAVE
 Oct:50
 Lo:0
 Hi:0
 Dry:80

PRE 1073
 Gain:50
 Bass-F:55
 Bass:12
 TRBL-F:10K
 Treble:0
 VOL:50
 MID-F:1.6K
 MID:0

OPT COMP
 Drive:7
 Lo:50
 Hi:60
 VOL:50

LEVEL: 60

BANK CM : POP MUSIC

361 : Pop Clean

This clean sound is perfect for smooth pop bass lines.

EBH 360

MB COMP

HALL

LEVEL 73

GAIN:20
BASS:58
MIDDLE:45
TREBLE:63
PRESENCE:36
VOLUME:50
MID-F:400
CHARA:OFF

Comp:70
LoTHR:50
HiTHR:50
VOL:43

PreD:35
Decay:7
Mix:15
Tail:OFF

362 : Pop Drive

This all around drive sound is good for pop music.

RC BOOST

BASS DRIVE

MONOTONE

SN 2x15

LEVEL 76

Gain:33
Bass:50
Treble:49
VOL:41

Bass:48
Treble:46
PRSNC:29
Blend:48
Gain:56
VOL:48
MID-F:1.0K
MID:61

GAIN:50
BASS:56
MIDDLE:48
TREBLE:50
PRESENCE:13
VOLUME:50
MODE:NORMAL

DYN20:53
DYN57:62
Bottom:60
BAL:100

363 : 80' Studio

This 80s-style studio sound for playing with a pick uses slapback delay.

PRE 1073

160 COMP

BASS GEQ

DELAY

LEVEL 63

Gain:50
Bass-F:55
Bass:3
TRBL-F:10K
Treble:0
VOL:65
MID-F:1.6K
MID:0

THRSH:-22
Ratio:4.0
Knee:HARD
VOL:89

50:0.0
120:0.0
400:0.0
500:0.0
800:4.0
4.5k:2.5
10k:0.0
VOL:80

Time:63
F.B:0
Mix:32
Tail:OFF

364 : Slap 42

This bright slap sound with a notable chorus effect is inspired by a bassist and vocalist who plays with a distinctive high-speed slapping "machine-gun style".

PRE 1073

LMT-76

TE 400

CLONE CHORUS

LEVEL 32

Gain:50
Bass-F:55
Bass:22
TRBL-F:10K
Treble:24
VOL:53
MID-F:700
MID:-14

Input:40
Ratio:8:1
REL:20
Output:47

GAIN:20
BASS:52
MIDDLE:55
TREBLE:77
PRESENCE:0
VOLUME:60
STYLE:SLAP
SHAPE:2

Depth:2
Rate:23
Tone:100
Mix:100

BANK CN : ROCK

365 : M's Milk

This slap sound is inspired by the fourth album of a rock band that came together in Los Angeles in 1983.

Diagram of a pedalboard for the '365 : M's Milk' sound. It features four pedals: Z TRON (orange), DUAL COMP (purple), EXCITER (orange), and TE 400 (green). A LEVEL knob is set to 85. Four red indicator lights are shown above the pedals.

Z TRON
Sense:3
RESO:7
Dry:22
VOL:83

DUAL COMP
FREQ:1.0K
LoCMP:8
HiCMP:24
VOL:72

EXCITER
Bass:72
Treble:94
VOL:56
ON/OFF:LATCH

TE 400
GAIN:20
BASS:65
MIDDLE:78
TREBLE:73
PRESENCE:0
VOLUME:54
STYLE:SLAP
SHAPE:OFF

LEVEL
85

366 : Blue Stone

This clean sound perfect for finger-playing is inspired by an American three-piece blues-rock band from Texas.

Diagram of a pedalboard for the '366 : Blue Stone' sound. It features five pedals: DI-5 (red), BASS PEQ (orange), HIGH EQ (orange), BMAN100 (grey), and SVT 8x10 (white). A LEVEL knob is set to 38. Five red indicator lights are shown above the pedals.

DI-5
Gain:60
Tone:3
HiCut:ON
VOL:80

BASS PEQ
FREQ:630
Q:2.5
Gain:-18.5
VOL:87

HIGH EQ
Type:SHELF
Gain:6.0
VOL:80

BMAN100
GAIN:50
BASS:44
MIDDLE:50
TREBLE:59
PRESENCE:0
VOLUME:79
MID-F:250
DEEP:OFF

SVT 8x10
DYN20:50
DYN57:54
Bottom:50
BAL:100

LEVEL
38

367 : RockSlap

This drive sound is perfect for slapping in rock styles. This can punch through even in aggressive songs.

Diagram of a pedalboard for the '367 : RockSlap' sound. It features three pedals: DYN COMP (purple), D.I PLUS (red), and IR (green). A LEVEL knob is set to 113. Three red indicator lights are shown above the pedals.

DYN COMP
Sense:4
ATTCK:FAST
Tone:64
VOL:58

D.I PLUS
ON/OFF
DIST
Bass:60
MID:51
Treble:51
Color:ON
CL VOL:50
BLEND:40
GAIN:52
DS VOL:46

IR
LO:50
HI:50
BAL:-12
VOL:4.4

LEVEL
113

368 : ProgBass

This sound is inspired by a Canadian bassist and vocalist known for his distinctive progressive playing.

Diagram of a pedalboard for the '368 : ProgBass' sound. It features three pedals: DARK OD (red), MONOTONE (grey), and SN 2x15 (grey). A LEVEL knob is set to 55. Three red indicator lights are shown above the pedals.

DARK OD
Gain:59
ATTCK:FLAT
Blend:50
VOL:76

MONOTONE
GAIN:50
BASS:57
MIDDLE:63
TREBLE:15
PRESENCE:29
VOLUME:29
MODE:BRIGHT

SN 2x15
DYN20:46
DYN57:78
Bottom:85
BAL:100

LEVEL
55

BANK CO : UK ROCK

369 : The Ox Rox

This drive sound is inspired by the bassist known as The Ox.

BASS DJENT PREAMP
ON/OFF HI BOOST

Bass:48
L-MID:71
H-MID:67
Treble:50
LoCut:40
Gain:14
VOL:40
HI BST:50

SUN CB

GAIN:64
BASS:50
MIDDLE:50
TREBLE:50
PRESENCE:0
VOLUME:40
INPUT:NORMAL
COLOR:OFF

SN 2x15

DYN20:50
DYN57:50
Bottom:60
BAL:100

LEVEL
60

370 : Synchroniz

This sound with a floating feel is inspired by a track from the 1983 fifth album from an English trio known for adding elements of reggae to rock.

KICK FLANGER
ON/OFF LFO

PreD:6
Depth:40
Rate:20
ON/OFF:LATCH
RESO:60
Mix:80
RST-F:50
LFO:RESET

AMPG SVT

GAIN:30
BASS:47
MIDDLE:53
TREBLE:46
PRESENCE:0
VOLUME:71
MID-F:200
ULTRA:OFF

IR

LO:45
HI:36
BAL:80
VOL:-18.0

ROOM

PreD:10
Decay:8
Mix:58
Tail:OFF

LEVEL
60

371 : Heartbreak

This sound is inspired by a famous song from the second album of a hard rock band that debuted in 1968 in England.

NYC MUFF

SUSTN:20
Tone:55
BAL:69
VOL:39

BASS OD

Gain:0
Tone:20
BAL:50
VOL:60

CLONE CHORUS

Depth:2
Rate:38
Tone:100
Mix:100

AC 370

GAIN:40
BASS:48
MIDDLE:58
TREBLE:58
PRESENCE:0
VOLUME:45
MID-F:220
BRIGHT:OFF

AC 1x18

DYN20:60
DYN57:57
Bottom:44
BAL:100

LEVEL
50

372 : RoundAB

This sound is inspired by the first track by an English prog rock band on their fourth album, released in 1971.

VOODOO -B

Gain:35
Tone:58
Blend:85
VOL:85

SUN CB

GAIN:50
BASS:64
MIDDLE:82
TREBLE:31
PRESENCE:0
VOLUME:46
INPUT:NORMAL
COLOR:OFF

IR

LO:50
HI:48
BAL:80
VOL:-18.0

LEVEL
85

BANK CP : HR&METAL

373 : 3 Finger

This drive sound suited for lead playing is inspired by a famous rock bassist known for tapping and three-finger playing.

DYN COMP
Sense:7
ATTCK:FAST
Tone:55
VOL:50

D.I PLUS
Bass:63
MID:32
Treble:8
Color:ON
CL VOL:50
BLEND:50
GAIN:0
DS VOL:63

BASS TS DRIVE
Gain:97
Tone:32
BAL:49
VOL:82

AMPG SVT
GAIN:23
BASS:61
MIDDLE:48
TREBLE:50
PRESENCE:0
VOLUME:99
MID-F:400
ULTRA:OFF

LEVEL
97

374 : Wrathchild

This sound is inspired by a heavy metal bassist known for distinctive percussive finger-playing.

DUAL COMP
FREQ:900
LoCMP:15
HiCMP:30
VOL:74

RC BOOST
Gain:26
Bass:54
Treble:54
VOL:38

BMAN100
GAIN:50
BASS:44
MIDDLE:73
TREBLE:82
PRESENCE:0
VOLUME:44
MID-F:630
DEEP:OFF

TE 4x10
DYN20:50
DYN57:68
Bottom:50
BAL:78

LEVEL
85

375 : EdgyBalls

This edgy slash metal sound is perfect for playing with a pick.

BMAN100
GAIN:61
BASS:33
MIDDLE:56
TREBLE:67
PRESENCE:0
VOLUME:50
MID-F:800
DEEP:OFF

SVT 8x10
DYN20:50
DYN57:50
Bottom:50
BAL:100

DARK PRE
Bass:30
L-MID:35
H-MID:45
Treble:40
Blend:80
Gain:81
VOL:65
BOOST:LO+HI

LEVEL
65

376 : Djent Bass

This Djent sound is metallic and crisp.

ZNR
DETCT:EFXIN
Depth:100
THRS:75
Decay:15

DARK OD
Gain:60
ATTCK:BOOST
Blend:60
VOL:75

MONOTONE
GAIN:50
BASS:72
MIDDLE:40
TREBLE:50
PRESENCE:10
VOLUME:39
MODE:BRIGHT

SN 2x15
DYN20:50
DYN57:42
Bottom:75
BAL:100

LEVEL
45

BANK CQ : SYNTH 1

377 : FunkyVoice

This creates a sound like a funky bass synth.

Z-SYNTH
 DYN/OFF A/B
 FREQ:3
 Range:8
 Decay:72
 RESO:13
 Wave:SAW
 Tone:8
 BAL:100
 VOL:18

MONOTONE
 GAIN:50
 BASS:52
 MIDDLE:70
 TREBLE:63
 PRESENCE:28
 VOLUME:44
 MODE:NORMAL

SN 2x15
 DYN20:60
 DYN57:70
 Bottom:55
 BAL:100

LEVEL
 80

378 : Synth Bass

This thick bass synthesizer sound uses an octaver effect.

Z-SYNTH
 DYN/OFF A/B
 FREQ:6
 Range:7
 Decay:66
 RESO:13
 Wave:SAW
 Tone:7
 BAL:86
 VOL:80

BASS ANALOG OCTAVE
 OCT1:26
 OCT2:0
 MOD:10
 Dry:80

MONOTONE
 GAIN:50
 BASS:60
 MIDDLE:50
 TREBLE:55
 PRESENCE:60
 VOLUME:26
 MODE:NORMAL

SN 2x15
 DYN20:50
 DYN57:60
 Bottom:65
 BAL:100

LEVEL
 49

379 : Low Devil

This bass synth sounds like crawling through dirt.

DYN COMP
 Sense:6
 ATTACK:SLOW
 Tone:50
 VOL:50

BASS STANDARD SYNTH
 Mode:DOWN
 Sense:50
 ATTACK:50
 Range:56
 RESO:58
 BAL:100
 VOL:80
 OCT:80

HALL
 PreD:14
 Decay:9
 Mix:20
 Tail:OFF

LEVEL
 80

380 : FM Bass

This creates a sound like an 80s digital bass synth. This is perfect for tight repetitive upbeat bass lines.

160 COMP
 THRSH:-22
 Ratio:7.9
 Knee:HARD
 VOL:80

Z-SYNTH
 DYN/OFF A/B
 FREQ:4
 Range:14
 Decay:33
 RESO:2
 Wave:SAW
 Tone:10
 BAL:70
 VOL:53

DI-5
 Gain:66
 Tone:OFF
 HiCut:ON
 VOL:40

BRIGHT ROOM
 PreD:5
 Decay:6
 Tone:7
 Mix:61

LEVEL
 43

BANK CR : SYNTH 2

381 : Chameleon

This synth sound suitable for jazz-funk uses a combination of Z-Syn and A-Filter.

Input:29
Ratio:4:1
REL:20
Output:38

FREQ:7
Range:6
Decay:72
RESO:13
Wave:SAW
Tone:7
BAL:64
VOL:80

Mode:UP
Sense:8
Peak:3
Dry:68

Depth:19
Rate:36
LoCut:120
Mix:18

LEVEL
35

382 : JustBeatIt

This synth sound is inspired by the intro of a famous 80s American pop song.

Comp:27
Lo:64
Hi:67
VOL:85

Type:UE
Sense:40
ATTCK:95
RESO:74
Tone:2
BAL:52
VOL:88
OCT:100

Range:1
RESO:7
Sense:10
BAL:5

Depth:80
Rate:42
LoCut:180
Mix:85

Time:417
F.B:40
Mix:17
Tail:OFF

LEVEL
16

383 : Raw Synth

This synth sound that uses Z-Syn has strong resonance.

Input:40
Lo:64
Hi:67
REL:20
Output:38

Gain:20
FLTR:44
VOL:64
DryMx:46

FREQ:4
Range:8
Decay:40
RESO:18
Wave:SAW
Tone:9
BAL:63
VOL:80

LEVEL
41

384 : MOOGYFONIC

This analog synth sound combines Z-Syn, Ba Octave and CloneCho effects.

Input:32
Ratio:4:1
REL:20
Output:46

FREQ:5
Range:8
Decay:72
RESO:18
Wave:SAW
Tone:7
BAL:80
VOL:80

Oct:23
Lo:5
Hi:9
Dry:80

Depth:2
Rate:23
Tone:73
Mix:39

LEVEL
27

BANK CS : CLEAN&DRV

385 : NYC Slap

This slap sound is good for jazz fusion.

DYN COMP
Sense:6
ATTCK:FAST
Tone:57
VOL:50

AMPG SVT
GAIN:30
BASS:75
MIDDLE:48
TREBLE:71
PRESENCE:0
VOLUME:71
MID-F:120
ULTRA:OFF

BASS PEQ
FREQ:100
Q:6.0
Gain:3.5
VOL:80

TAPE ECHO
Time:560
F.B:64
Mix:8
Tail:OFF

LEVEL
47

386 : Sweet SVT

This simple clean sound combines LMT-76 and AMPG SVT.

LMT-76
Input:31
Ratio:4:1
REL:20
Output:54

AMPG SVT
GAIN:26
BASS:61
MIDDLE:63
TREBLE:50
PRESENCE:0
VOLUME:71
MID-F:220
ULTRA:OFF

LEVEL
25

387 : DirtyOGB15

This dirty drive sound combines FlipTop and CloneCho.

BLACK OPT
Comp:29
Lo:50
Hi:50
VOL:76

FLIP TOP
GAIN:30
BASS:61
MIDDLE:59
TREBLE:51
PRESENCE:0
VOLUME:70
BRIGHT:OFF
ULTRA:HI

CLONE CHORUS
Depth:1
Rate:29
Tone:86
Mix:40

LEVEL
30

388 : DISTORT ME

Combining DYN Comp and D.I Plus, this distortion sound has a nice attack.

DYN COMP
Sense:6
ATTCK:SLOW
Tone:50
VOL:50

D.I PLUS
ON/OFF DIST
Bass:66
MID:50
Treble:67
Color:ON
CL VOL:50
BLEND:52
GAIN:46
DS VOL:85

TAPE ECHO
Time:560
F.B:64
Mix:12
Tail:OFF

LEVEL
32

BANK CT : DRIVE

389 : US Punk

This sound is inspired by West Coast American skate punk from the 2000s.

Exciter
 Bass:0
 Treble:53
 VOL:65
 ON/OFF:LATCH

AMPG SVT
 GAIN:44
 BASS:30
 MIDDLE:66
 TREBLE:64
 PRESENCE:0
 VOLUME:95
 MID-F:1.0K
 ULTRA:OFF

SVT 8x10
 DYN20:29
 DYN57:57
 Bottom:29
 BAL:100

LEVEL
 98

390 : RockDrive

This drive sound is perfect for rock.

SQUEAK
 Gain:27
 FLTR:43
 VOL:50
 DryMx:63

BASS OD
 Gain:30
 Tone:14
 BAL:63
 VOL:60

BMAN100
 GAIN:59
 BASS:64
 MIDDLE:58
 TREBLE:77
 PRESENCE:0
 VOLUME:51
 MID-F:160
 DEEP:OFF

SN 2x15
 DYN20:55
 DYN57:71
 Bottom:65
 BAL:100

LEVEL
 60

391 : DirtyDist

This classic distortion sound is thick and rough.

BMAN100
 GAIN:50
 BASS:44
 MIDDLE:50
 TREBLE:59
 PRESENCE:0
 VOLUME:50
 MID-F:250
 DEEP:OFF

VOODOO -B
 Gain:41
 Tone:46
 Blend:100
 VOL:80

LEVEL
 78

392 : Race Car

This low-fi fuzz sound cuts the low-end.

MONOTONE
 GAIN:50
 BASS:0
 MIDDLE:63
 TREBLE:80
 PRESENCE:59
 VOLUME:80
 MODE:NORMAL

MT 1x15
 DYN20:50
 DYN57:70
 Bottom:27
 BAL:100

VOODOO -B
 Gain:39
 Tone:71
 Blend:92
 VOL:80

LEVEL
 47

BANK CU : FUZZ&OCT

393 : FuzzyLead

This fuzz sound, which includes BaFzSmile and BaMnPitch, is good for lead play.

Input:40
Ratio:4:1
REL:20
Output:51

Shift:12
Fine:0
Tone:10
BAL:10

FREQ:125
Lo:58
Hi:46
VOL:83

Gain:28
Tone:38
BAL:100
VOL:80

Time:560
F.B:30
Mix:14
Tail:OFF

LEVEL
81

394 : Fuzzynator

This flanger sound combines BassOctFZ with BaVinFLNG.

Sense:6
ATTCK:FAST
Tone:50
VOL:13

Boost:70
Tone:23
Fuzz:61
Dry:64

Depth:47
Rate:7
RESO:8
LoCut:120

LEVEL
47

395 : Octavious

This octave sound uses Ba AnaOct and has a light filtering effect with Bass Cry.

Input:40
Ratio:4:1
REL:20
Output:38

OCT1:26
OCT2:8
MOD:29
Dry:83

Range:4
RESO:9
Sense:8
BAL:15

LEVEL
51

396 : OctaFlange

This crossover sound combines Ba AnaOct and BaVinFLNG effects.

Input:26
Ratio:4:1
REL:20
Output:65

OCT1:11
OCT2:0
MOD:17
Dry:86

Depth:23
Rate:7
RESO:8
LoCut:400

LEVEL
24

BANK CV : OCTAVER

397 : Octaver

This is a typical octaver sound of the 80s and 90s.

Gain:40
LoType:SHLF
LoFREQ:80
Lo:0
HiFREQ:1.5K
Hi:6
VOL:87
HMNCS:50

OCT1:28
OCT2:0
MOD:0
Dry:75

Bass:23
Treble:49
VOL:69
ON/OFF:LATCH

LEVEL
52

398 : OctChorus

This cool bass sound combines octaver and chorus effects.

OCT1:65
OCT2:8
MOD:25
Dry:86

Depth:75
Rate:19
LoCut:200
Mix:76

LEVEL
69

399 : OctVerb

This wide sounds combines octaver and reverb effects.

FREQ:1.5K
LoCMP:24
HiCMP:24
VOL:75

Oct:36
Lo:2
Hi:8
Dry:98

Bass:88
L-MID:61
H-MID:50
Treble:45
Blend:41
Gain:39
VOL:78
BOOST:LO

PreD:1
Decay:20
Mix:50
Tail:OFF

LEVEL
41

400 : ReggaeSub

This sound that emphasizes super low frequencies is good for reggae and dub styles.

Gain:50
ENHNC:45
Lo:54
Mid:65
Hi:27
BAL:100
VOL:52
SUB:64

Gain:2
Tone:54
Blend:38
VOL:72

GAIN:30
BASS:50
MIDDLE:50
TREBLE:50
PRESENCE:0
VOLUME:71
MID-F:220
ULTRA:OFF

DYN20:50
DYN57:50
Bottom:50
BAL:100

LEVEL
87

BANK CW : FILTER&WAH

401 : Fretless

This sound simulates a fretless bass, combining Defret and BassStCho.

Input:33
Ratio:4:1
REL:20
Output:62

Gain:44
Tone:6
HiCut:ON
VOL:80

Sense:0
Color:8
Tone:37
VOL:80

Depth:28
Rate:27
LoCut:180
Mix:26

Time:560
F.B:30
Mix:16
Tail:OFF

LEVEL
42

402 : FilterThis

This funky filter sound, which uses EnvFilter, can be used for both rhythm and lead parts.

Sense:2
ATTCK:FAST
Tone:39
VOL:95

Gain:35
LoType:SHELF
LoFREQ:97
Lo:9
HiFREQ:5.9K
Hi:2
VOL:100
HMNCS:79

THRSH:5
ATTCK:80
Mode:UP
VOL:84

Time:560
F.B:30
Mix:9
Tail:OFF

LEVEL
33

403 : WahsMyFuzz

This filtered phase sound combines VooDoo-B and Bass Cry.

THRSH:-22
Ratio:4:0
Knee:SOFT
VOL:80

Gain:41
Tone:46
Blend:45
VOL:80

Range:4
RESO:9
Sense:8
BAL:25

LEVEL
93

404 : FunnyFunk

This auto-wah sound is good for funky bass lines.

Gain:42
LoType:PEQ
LoFREQ:80
Lo:5
HiFREQ:1.5K
Hi:5
VOL:87
HMNCS:70

Sense:2
RESO:3
Dry:0
VOL:73

THRSH:-23
Ratio:2.5
Knee:HARD
VOL:95

LEVEL
45

BANK CX : FUNKY EFX

405 : WawaFriend

This analog filter sound combines Pre1073 and EnvFilter effects.

Input:23
Ratio:4:1
REL:20
Output:62

Gain:45
Bass-F:55
Bass:15
TRBL-F:10K
Treble:1
VOL:60
MID-F:700
MID:20

THRSH:15
ATTCK:0
Mode:UP
VOL:94

Time:560
F.B:23
Mix:10
Tail:OFF

LEVEL
30

406 : Wah Solo

This auto-wah sound is perfect for emotional solos.

Sense:1
RESO:6
Dry:50
VOL:80

Sense:7
ATTCK:SLOW
Tone:68
VOL:50

Gain:100
Tone:58
BAL:56
VOL:90

GAIN:30
BASS:50
MIDDLE:61
TREBLE:56
PRESENCE:0
VOLUME:28
MID-F:150
ULTRA:OFF

PreD:49
Decay:10
Mix:46
Tail:OFF

LEVEL
80

407 : FunkySolo

Hard compression is applied to this phase sound. Turn Bomber ON for the end of a solo.

Comp:80
LoTHR:60
HiTHR:40
VOL:61

Color:INV 8
Depth:84
Rate:15
RESO:70

FREQ:125
Lo:38
Hi:44
VOL:80

PreD:40
Decay:10
Mix:8
Tail:OFF

Decay:48
Tone:10
Mix:89
ON/OFF:TRGGR

LEVEL
55

408 : Jet Bomber

This intense explosive sound is like a jet.

Decay:80
Tone:8
Mix:26
ON/OFF:LATCH

Depth:60
Rate:19
RESO:8
LoCut:180

PreD:44
Decay:52
Mix:44
Tail:OFF

LEVEL
100

BANK CY : MODULATION

409 : CureLike

This is the clean sound of AMPG SVT combined with chorus and flanger effects.

LEVEL: 59

AMPG SVT
 GAIN:75
 BASS:40
 MIDDLE:40
 TREBLE:40
 PRESENCE:10
 VOLUME:71
 MID-F:160
 ULTRA:BOTH

SVT 8x10
 DYN20:50
 DYN57:50
 Bottom:50
 BAL:100

BASS STEREO CHORUS
 Depth:75
 Rate:27
 LoCut:180
 Mix:76

BASS VINTAGE FLANGER
 Depth:65
 Rate:3
 RESO:2
 LoCut:OFF

410 : SlapDtune

Adding tone that has been slightly shifted in pitch and time give thickness to this slap sound.

LEVEL: 120

BASS DETUNE
 Cent:18
 PreD:0
 Tone:9
 Mix:35

BASS DETUNE
 Cent:-18
 PreD:0
 Tone:8
 Mix:35

DUAL DELAY
 ON/OFF MOD
 TimeA:81
 F.B A:1
 TimeB:170
 F.B B:1
 DlyMx:0
 BAL:6
 DEPTH:MN-0
 SPEED:25

HIGH EQ
 Type:SHELF
 FREQ:10k
 Gain:4.0
 VOL:90

411 : HotMonkey

This is a fuzzy flanger sound. This can be made even more aggressive by playing with a pick.

LEVEL: 48

ENV FILTER
 THRSH:8
 ATTK:66
 Mode:UP
 VOL:45

BASS OCT FUZZ
 Boost:73
 Tone:50
 Fuzz:34
 Dry:48

BASS VINTAGE FLANGER
 Depth:47
 Rate:7
 RESO:8
 LoCut: 60

BRIGHT HALL
 PreD:49
 Decay:10
 Tone:5
 Mix:46

412 : StarshipTr

This is a tremolo sound that stands out.

LEVEL: 100

FLIP TOP

TE 4x10

TREMOLLO
 Wave:TRI
 Depth:90
 Rate:50
 VOL:62

GAIN:30
 BASS:80
 MIDDLE:50
 TREBLE:60
 PRESENCE:0
 VOLUME:70
 BRIGHT:OFF
 ULTRA:OFF

DYN20:50
 DYN57:50
 Bottom:50
 BAL:100

BANK CZ : TREMOLO

413 : WesternMOV

Combining Tremolo and AnalogDly, this sound is inspired by Western films.

LEVEL: 12

LMT-76 Input:40 Ratio:8:1 REL:20 Output:53	PRE 1073 Gain:40 Bass-F:55 Bass:7 TRBL-F:10K Treble:7 VOL:80 MID-F:700 MID:20	TREMOLO Wave:TUBE Depth:73 Rate:67 VOL:87	VOODOO -B Gain:39 Tone:59 Blend:6 VOL:83	ANALOG DELAY Time:360 F.B:28 Mix:24 Tail:OFF
---	--	--	---	---

414 : SawFuzzing

This fuzz sound combines Tremolo and BaFzSmile.

LEVEL: 72

DYN COMP Sense:6 ATTCK:FAST Tone:46 VOL:57	TREMOLO Wave:TUBE Depth:50 Rate:56 VOL:69	BA FZ SMILE Gain:43 Tone:84 BAL:60 VOL:80	EXCITER Bass:59 Treble:50 VOL:49 ON/OFF:LATCH
---	--	--	--

415 : MagnumGuy

This thick tremolo sound combines Squeak, BaAnaOct and Tremolo effects.

LEVEL: 42

DYN COMP Sense:6 ATTCK:FAST Tone:50 VOL:48	BASS ANALOG OCTAVE OCT1:65 OCT2:8 MOD:25 Dry:86	SQUEAK Gain:47 FLTR:66 VOL:79 DryMx:71	TREMOLO Wave:SQR Depth:92 Rate:73 VOL:62
---	--	---	---

416 : BlackHawk

This fuzz sound, which includes BaFzSmile and Tremolo, is good for playing long notes.

LEVEL: 53

LMT-76 Input:40 Ratio:12:1 REL:20 Output:18	BA FZ SMILE Gain:79 Tone:85 BAL:48 VOL:87	TREMOLO Wave:SQR Depth:91 Rate:75 VOL:89	BASS PHASE Color:1 Depth:100 Rate:55 RESO:56
--	--	---	---

BANK DA : PITCH&SYN

417 : MoStrings

This sound takes a fifth harmony and shifts it another octave.

LEVEL: 36

LMT-76 Input:27 Ratio:4:1 REL:20 Output:60	PITCH SHIFT Shift:7 Fine:0 Tone:3 BAL:27	POLY SHIFT Shift:12 Tone:68 Wet:60 Dry:80	DELAY Time:560 F.B:30 Mix:13 Tail:OFF
---	---	--	--

418 : Metheneish

Ba PDLmNp and VooDoo-B are combined with CloneCho in this synth brass style sound.

LEVEL: 43

LMT-76 Input:26 Ratio:4:1 REL:49 Output:46	BASS PEDAL MONO PITCH Bend:100 Color:+1 OCT Tone:5 Mode:UP	VOODOO -B Gain:16 Tone:66 Blend:84 VOL:80	CLONE CHORUS Depth:2 Rate:23 Tone:100 Mix:100	TAPE ECHO Time:560 F.B:24 Mix:21 Tail:OFF
---	---	--	--	--

419 : Minotaurio

This synth sound with harmony a third up combines BaStdSyn and HPS (Key C).

LEVEL: 26

LMT-76 Input:40 Ratio:4:1 REL:20 Output:47	BASS STANDARD SYNTH Mode:UP Sense:64 ATTK:50 Range:64 RESO:57 BAL:40 VOL:80 OCT:87	H.P.S Scale:3 Key:C Tone:7 Mix:80	SPLITTER FREQ:100 Lo:46 Hi:64 VOL:80	DELAY Time:560 F.B:30 Mix:19 Tail:OFF
---	---	--	---	--

420 : BubbSynth

This synth sound with strong resonance combines Z-Synth, Z Tron and Bass Cry.

LEVEL: 15

LMT-76 Input:40 Ratio:4:1 REL:20 Output:37	Z-SYNTH FREQ:9 Range:18 Decay:39 RESO:15 Wave:SAW Tone:10 BAL:42 VOL:71	Z TRON Sense:2 RESO:6 Dry:76 VOL:83	BASS CRY Range:4 RESO:8 Sense:8 BAL:19
---	--	--	---

BANK DB : DELAY 1

421 : HarmChords

This delay sound is perfect for playing chords.

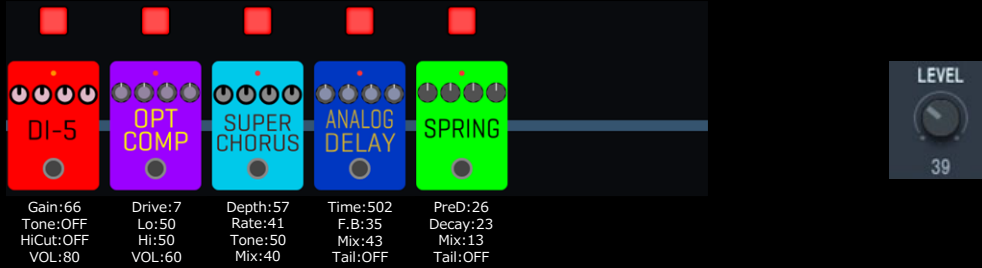

DI-5 OPT COMP SUPER CHORUS ANALOG DELAY SPRING

Gain:66 Tone:OFF HiCut:OFF VOL:80 Drive:7 Lo:50 Hi:50 VOL:60 Depth:57 Rate:41 Tone:50 Mix:40 Time:502 F.B:35 Mix:43 Tail:OFF PreD:26 Decay:23 Mix:13 Tail:OFF

LEVEL 39

422 : Tapping

This all-mighty tapping sound creates a feeling of chords.

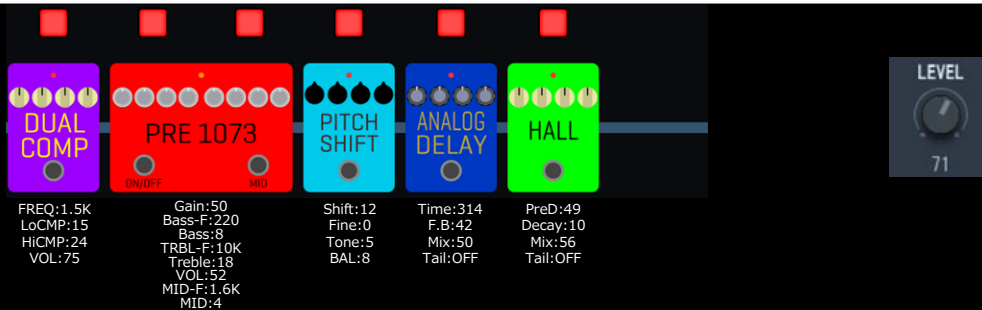

DUAL COMP PRE 1073 PITCH SHIFT ANALOG DELAY HALL

FREQ:1.5K LoCMP:15 HiCMP:24 VOL:75 Gain:50 Bass-F:220 Bass:8 TRBL-F:10K Treble:18 VOL:52 MID-F:1.6K MID:4 Shift:12 Fine:0 Tone:5 BAL:8 Time:314 F.B:42 Mix:50 Tail:OFF PreD:49 Decay:10 Mix:56 Tail:OFF

LEVEL 71

423 : Solo Bass

Combining delay and reverb, this clean sound is good for playing solos.



TAPE ECHO PLATE BLACK OPT

Time:560 F.B:64 Mix:56 Tail:OFF PreD:9 Decay:52 Mix:44 Tail:OFF Comp:50 Lo:50 Hi:50 VOL:76

LEVEL 100

424 : SpaceDelay

This spacey sounds combines auto-wah and delay.



SLOW ATTACK BASS A-WAH DELAY

Time:21 Curve:10 Tone:100 VOL:80 Sense:2 RESO:8 Dry:50 VOL:80 Time:560 F.B:30 Mix:70 Tail:OFF

LEVEL 100

BANK DC : DELAY 2

425 : Dramabass

This ambient sound combines TheVibe with Dual DLY.

LEVEL: 21

LMT-76	THE VIBE	CORONA TRI	DUAL DELAY
Input:40 Ratio:4:1 REL:20 Output:52	Speed:18 Depth:60 Mode:CHORS VOL:80	Depth:100 Speed:28 Tone:100 Mix:66	TimeA:500 F.B A:50 TimeB:375 F.B B:50 DlyMx:24 BAL:17 DEPTH:MN-0 SPEED:25

426 : Lowismo

This delay sound that emphasizes notes an octave below is good for lead playing.

LEVEL: 42

DYN COMP	BASS MONO PITCH	SPLITTER	BASS STEREO CHORUS	TAPE ECHO
Sense:6 ATTCK:SLOW Tone:50 VOL:50	Shift:-12 Fine:0 Tone:7 BAL:50	FREQ:125 Lo:32 Hi:38 VOL:80	Depth:75 Rate:27 LoCut:180 Mix:76	Time:560 F.B:64 Mix:56 Tail:OFF

427 : Copy Glass

A combination of BaPiShift and Dual DLY creates this glass-like sound.

LEVEL: 30

LMT-76	POLY SHIFT	DUAL DELAY	KICK FLANGER
Input:40 Ratio:4:1 REL:20 Output:47	Shift:12 Tone:90 Wet:60 Dry:95	TimeA:500 F.B A:50 TimeB:375 F.B B:50 DlyMx:17 BAL:23 DEPTH:MN-0 SPEED:25	PreD:4 Depth:61 Rate:41 ON/OFF:LATCH RESO:73 Mix:10 RST-F:50 LFO:RESET

428 : OUTAWORLD

The combination of PitchSHFT and ReverseDL create this mystical sound.

LEVEL: 34

LMT-76	PITCH SHIFT	REVERSE DELAY	CORONA TRI
Input:40 Ratio:4:1 REL:20 Output:53	Shift:7 Fine:0 Tone:10 BAL:60	Time:1000 F.B:20 BAL:50 Tail:OFF	Depth:100 Speed:13 Tone:100 Mix:45

BANK DD : SFX

429 : SwellUpper

This ambient tone that is good for playing long notes uses SlowATTCK and adds octaves above and below.

LEVEL: 10

SLOW ATTACK Time:21 Curve:10 Tone:100 VOL:100	BASS ANALOG OCTAVE OCT1:65 OCT2:6 MOD:18 Dry:65	BASS PEDAL MONO PITCH Bend:100 Color:DWN/OCT Tone:7 Mode:UP	PRE 1073 Gain:50 Bass:F:55 Bass:0 TRBL:F:10K Treble:0 VOL:91 MID-F:1.6K MID:0	TAPE ECHO Time:560 F.B:64 Mix:18 Tail:OFF
--	--	--	--	--

430 : Lunarchoir

The combination of BaMnPitch, PitchSHFT and ReverseDL provides an effective organ sound.

LEVEL: 11

LMT-76 Input:40 Ratio:8:1 REL:20 Output:49	BASS MONO PITCH Shift:24 Fine:0 Tone:7 BAL:62	PITCH SHIFT Shift:7 Fine:0 Tone:7 BAL:57	CORONA TRI Depth:100 Speed:22 Tone:100 Mix:72	REVERSE DELAY Time:1000 F.B:20 BAL:50 Tail:OFF
---	--	---	--	---

431 : PlayThe4

This mysterious delay sound uses a four-semitone pitch shift.

LEVEL: 50

DYN COMP Sense:6 ATTCK:FAST Tone:64 VOL:60	TE 400 GAIN:21 BASS:52 MIDDLE:55 TREBLE:62 PRESENCE:0 VOLUME:71 STYLE:FINGER SHAPE:OFF	BASS MONO PITCH Shift:4 Fine:4 Tone:4 BAL:29	BASS CRY Range:3 RESO:6 Sense:7 BAL:20	DELAY Time:520 F.B:20 Mix:20 Tail:OFF
---	---	---	---	--

432 : Got Swells

This sequencer sound is suitable for long notes.

LEVEL: 56

DYN COMP Sense:6 ATTCK:FAST Tone:80 VOL:93	SLOW ATTACK Time:21 Curve:10 Tone:100 VOL:80	POLY SHIFT Shift:12 Tone:90 Wet:30 Dry:88	SEQ FILTER Step:8 PTTRN:7 Speed:26 RESO:10	PLATE PreD:9 Decay:52 Mix:15 Tail:OFF
---	---	--	---	--

BANK DE : Aco.Basic

433 : PiezoUpRig

This is a basic clean sound for upright bass.

Input: 40
Ratio: 8:1
REL: 20
Output: 59

Gain: 25
Bass-F: 55
Bass: 17
TRBL-F: 10K
Treble: 12
VOL: 92
MID-F: 700
MID: 22

PreD: 67
Decay: 50
Mix: 33
Tail: OFF

LEVEL
10

434 : Soloist

This clean sound combines LMT-76 and Pre1073.

Input: 27
Ratio: 4:1
REL: 55
Output: 47

Gain: 40
Bass-F: 220
Bass: 8
TRBL-F: 10K
Treble: 0
VOL: 60
MID-F: 700
MID: 0

Time: 560
F.B: 44
Mix: 11
Tail: OFF

LEVEL
120

435 : SalsaBassQ

This is a clean sound for playing salsa on upright bass.

Input: 40
Ratio: 8:1
REL: 20
Output: 53

GAIN: 39
BASS: 64
MIDDLE: 39
TREBLE: 56
PRESENCE: 0
VOLUME: 81
DEEP: ON
BRIGHT: OFF

DYN20: 50
DYN57: 50
Bottom: 50
BAL: 100

PreD: 49
Decay: 10
Mix: 46
Tail: ON

LEVEL
10

436 : Uborchestr

This lead tone for upright bass adds fifths.

Input: 40
Ratio: 8:1
REL: 20
Output: 68

Shift: 7
Fine: 0
Tone: 8
BAL: 17

Gain: 30
Bass-F: 55
Bass: 13
TRBL-F: 10K
Treble: 24
VOL: 65
MID-F: 700
MID: 19

Depth: 80
Rate: 62
Tone: 51
Mix: 42

PreD: 43
Decay: 16
Mix: 30
Tail: OFF

LEVEL
20

BANK DF : Aco.Bow&FX

437 : BowOrch

This lead tone for upright bass is good for playing with a bow.

LEVEL: 15

LMT-76 Input:40 Ratio:8:1 REL:20 Output:65	BASS MONO PITCH Shift:-12 Fine:0 Tone:10 BAL:26	PRE 1073 Gain:30 Bass-F:220 Bass:10 TRBL-F:16K Treble:15 VOL:60 MID-F:700 MID:11	SPLITTER FREQ:100 Lo:52 Hi:62 VOL:80	HALL PreD:37 Decay:10 Mix:17 Tail:OFF
---	--	---	---	--

438 : BowUpright

This basic clean sound for upright bass is good for playing with a bow.

LEVEL: 8

LMT-76 Input:40 Ratio:8:1 REL:20 Output:66	PRE 1073 Gain:25 Bass-F:55 Bass:11 TRBL-F:16K Treble:6 VOL:32 MID-F:700 MID:13	BASS STEREO CHORUS Depth:54 Rate:43 LoCut:60 Mix:30	SPLITTER FREQ:160 Lo:54 Hi:58 VOL:80	BRIGHT HALL PreD:15 Decay:10 Tone:5 Mix:46
---	---	--	---	---

439 : Marscoding

This modulation sound for upright bass uses PitchSHFT and Bass Cry effects.

LEVEL: 6

LMT-76 Input:40 Ratio:8:1 REL:20 Output:70	PITCH SHIFT Shift:4 Fine:0 Tone:7 BAL:20	BASS CRY Range:4 RESO:9 Sense:4 BAL:48	PRE 1073 Gain:30 Bass-F:220 Bass:14 TRBL-F:10K Treble:13 VOL:91 MID-F:1.6K MID:16	THE VIBE Speed:17 Depth:60 Mode:VIBRT VOL:75
---	---	---	--	---

440 : MYOWNCOMPS

This sequencer sound for upright bass uses PitchSHFT and SeqFLTR.

LEVEL: 7

BLACK OPT Comp:50 Lo:50 Hi:49 VOL:90	PITCH SHIFT Shift:7 Fine:0 Tone:9 BAL:15	SEQ FILTER Step:8 PTRN:7 Speed:26 RESO:10	AG 750 GAIN:68 BASS:57 MIDDLE:56 TREBLE:56 PRESENCE:0 VOLUME:84 DEEP:OFF BRIGHT:ON	BASS STEREO CHORUS Depth:76 Rate:27 LoCut:60 Mix:18
---	---	--	---	--



ZOOM CORPORATION

4-4-3 Kanda-surugadai, Chiyoda-ku, Tokyo 101-0062 Japan
zoomcorp.com

Z21-3846-02